



**Teileliste und Näheinrichtungen
Spare Parts List and Sewing Equipment**

971 · 972

DÜRKOPP ADLER AG

Postfach 6 · D-4800 Bielefeld 1 · Potsdamer Straße 190 · Telefon (0521) 556-01
Telex 932400-0 dw d · Telefax (0521) 5561315



Teileliste und Näheinrichtungen Spare Parts List and Sewing Equipment

971 · 972

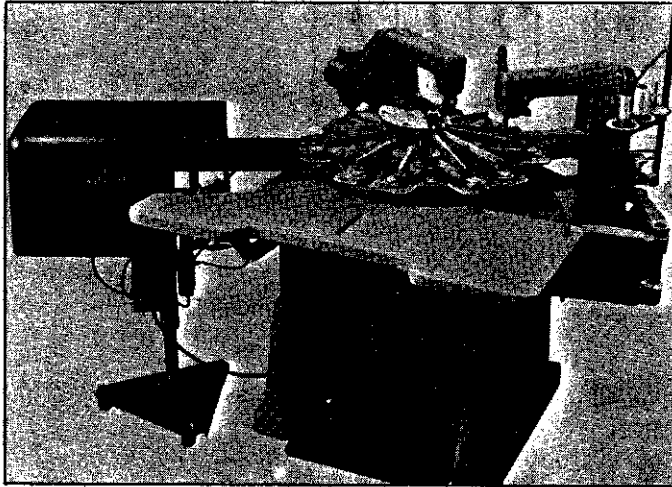

Zusatzaggregate:
Complementary equipment:
Équipement supplémentaire:
Aparatos especiales:

Nähguthalter
Sewing fabric holder
Porte-pince
Sujeta material

Stapler
Stacker
Empileur
Apilador

Kettfadentrenner
Chain thread cutter
Coupeur de chainette
Separador del hilo de cadeneta

Einschneideinrichtung: nur für Kl. 972-210
Incising unit: (972-210)
Dispositif de coupage: (seulement pour Cl. 972-210)
Dispositivo para hacer incisiones: (solo para modelo 972-210)

971 Automat mit Doppelkettenstich-Nähkopf,
Stichtyp 401 (ohne Eckenstich) min r = 3,5 mm
Automatic with double chain stitch-sewing head
stitch type 401 (without corner stitch) min. r = 3,5 mm
Automate avec tête de piquage pour double point de chainette
Type de point 401 (sans point angulaire) r. min 3,5 mm
Automata con cabezal de coser de punto doble de cadeneta
tipo de puntada 401 (sin puntada en la esquina) r. min. = 3,5 mm

972 Automat mit Doppelstepstich-Nähkopf,
Stichtyp 301 (Eckenstich)
Automatic with double lockstitch-sewing head
stitch type 301 (with corner stitch)
Automate avec tête de piquage pour double point de couture
Type de point 301 (avec point angulaire)
Automata con cabezal de coser de doble respunte
Tipo de puntada 301 (con puntada en la esquina)

Unterklassenschlüssel: Subclass key: Designation des sous-classes: Clasificación de las subclases y su clave:		971	972	200/	1
Hauptklasse: Main class: Classe principale: Modelo base:					
Beschneider:	ohne = 2 mit = 8				
Trimmer:	without = 2 with = 8				
Dispositif de coupe:	sans = 2 avec = 8				
Cabezal recortador:	sin = 2 con = 8				
Nähguthalter:	starr = 0 verstellbar 4er Tlg. = 1 verstellbar 6er Tlg. = 2				
Sewing fabric holder:	rigid = 0 adjustable in 4 parts = 1 adjustable in 6 parts = 2				
Porte-matière à coudre:	fix = 0 réglable à 4 pièces = 1 réglable à 6 pièces = 2				
Sujeta material:	fijo = 0 regulable de 4 puestos = 1 regulable de 6 puestos = 2				
Erweiterungsstelle:	nicht belegt = 0 für Krawatten = 1 für Handschuhe = 3				
Expanding position:	free = 0 for ties = 1 for gloves = 3				
Expension:	libre = 0 pour chravattes = 1 pour gants = 3				
Renglor indicando:	libro = 0 corbatas = 1 guantes = 3				
Elektrische Ausführung: Electrical equipment: Execution électrique: Equipo electrico:					
	3 x 380 V, 50 Hz + N (Mp) = 1 3 x 220 V, 50 Hz = 2 3 x 220 V, 60 Hz = 3 3 x 415 V, 50 Hz + N (Mp) = 4				

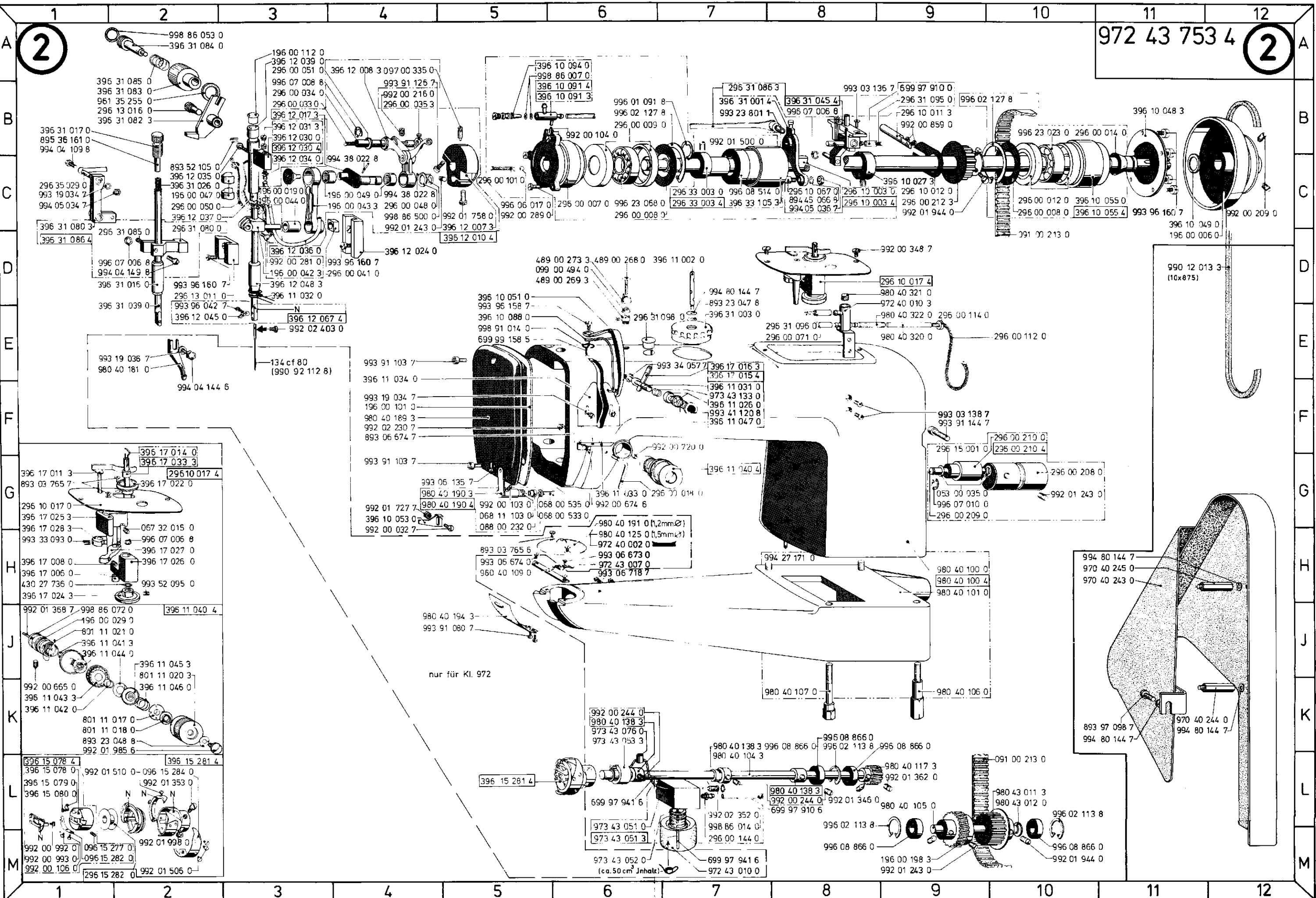

972 43 753 4

nur für Kl. 972

971, 972
Beschneider

3

3

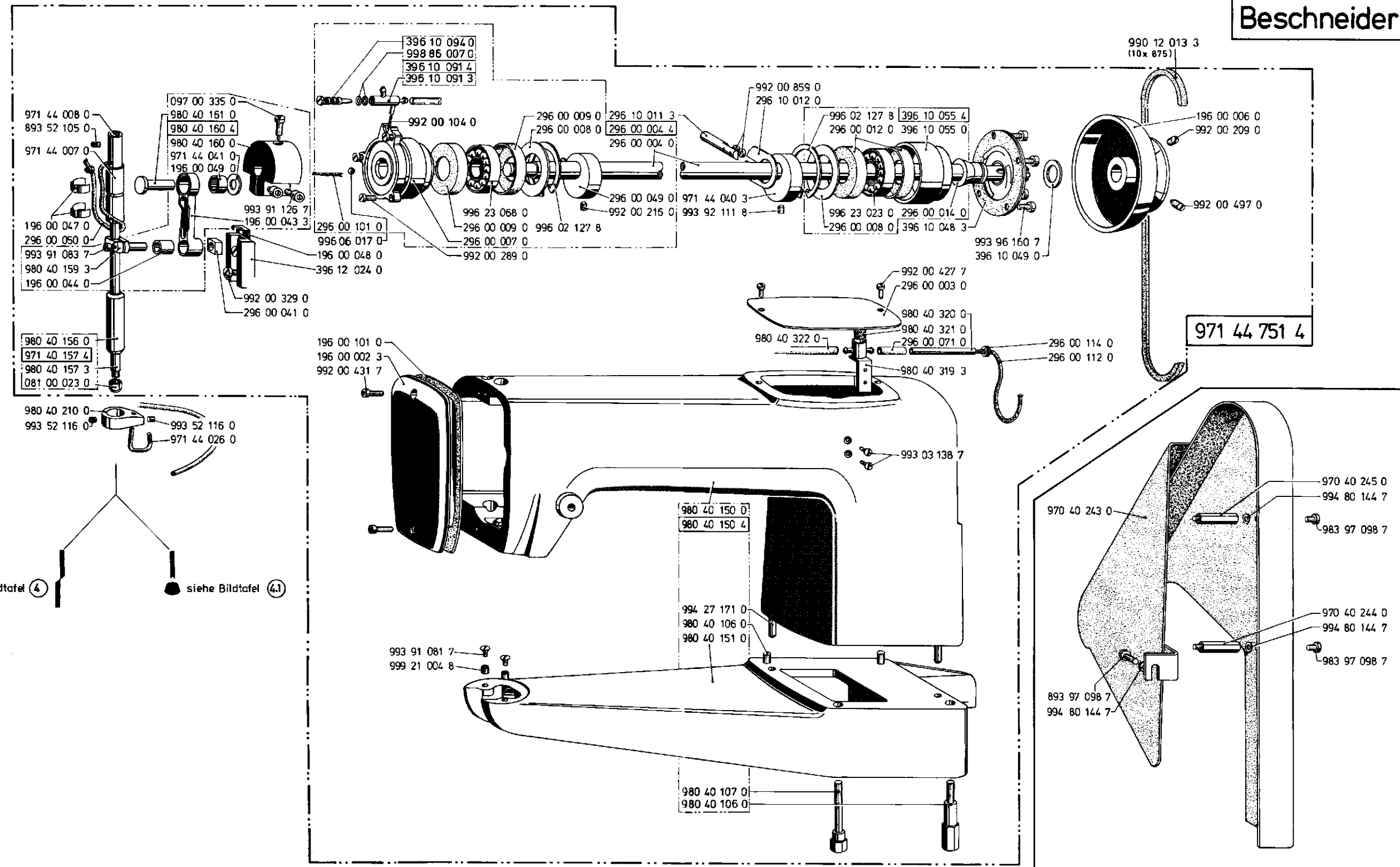

4

4

Scherkopfausführungen
Shearing head types
Machines a cuper
Cachillas

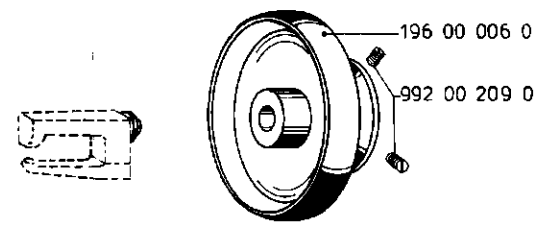
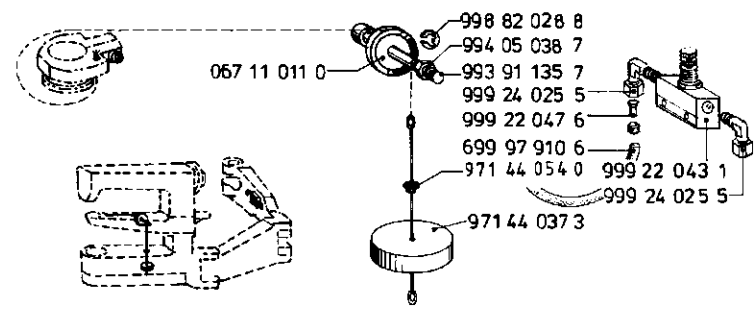
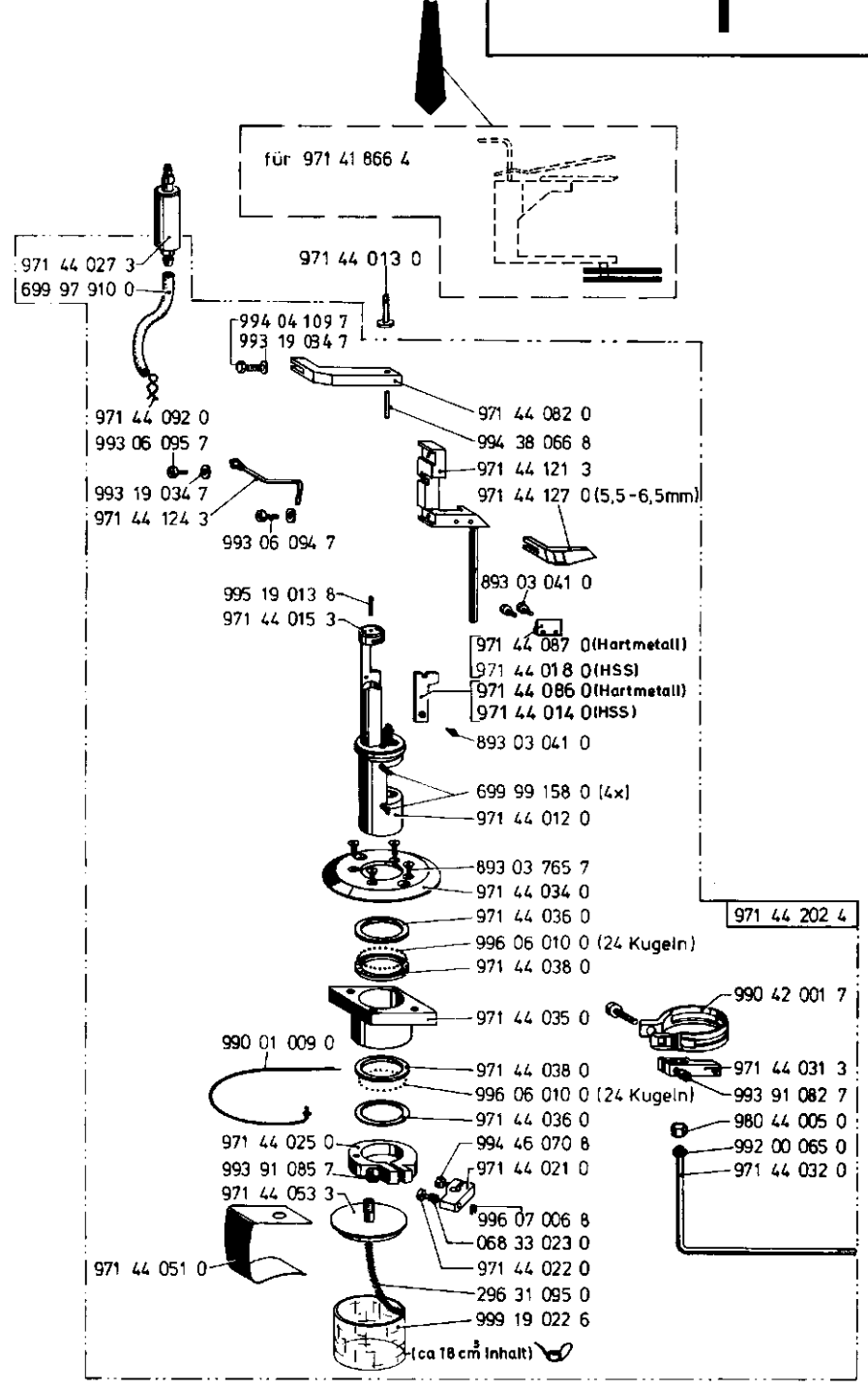
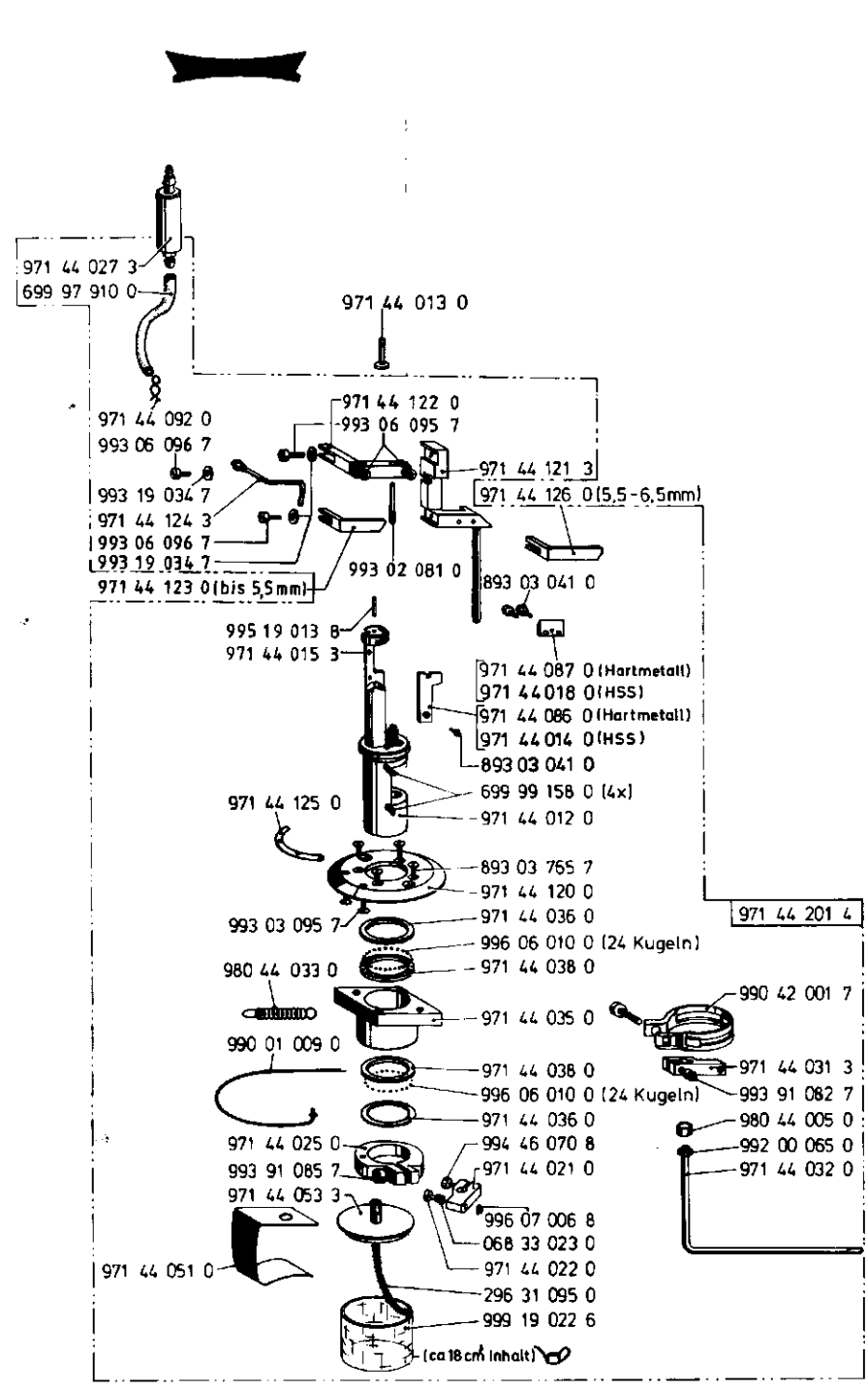
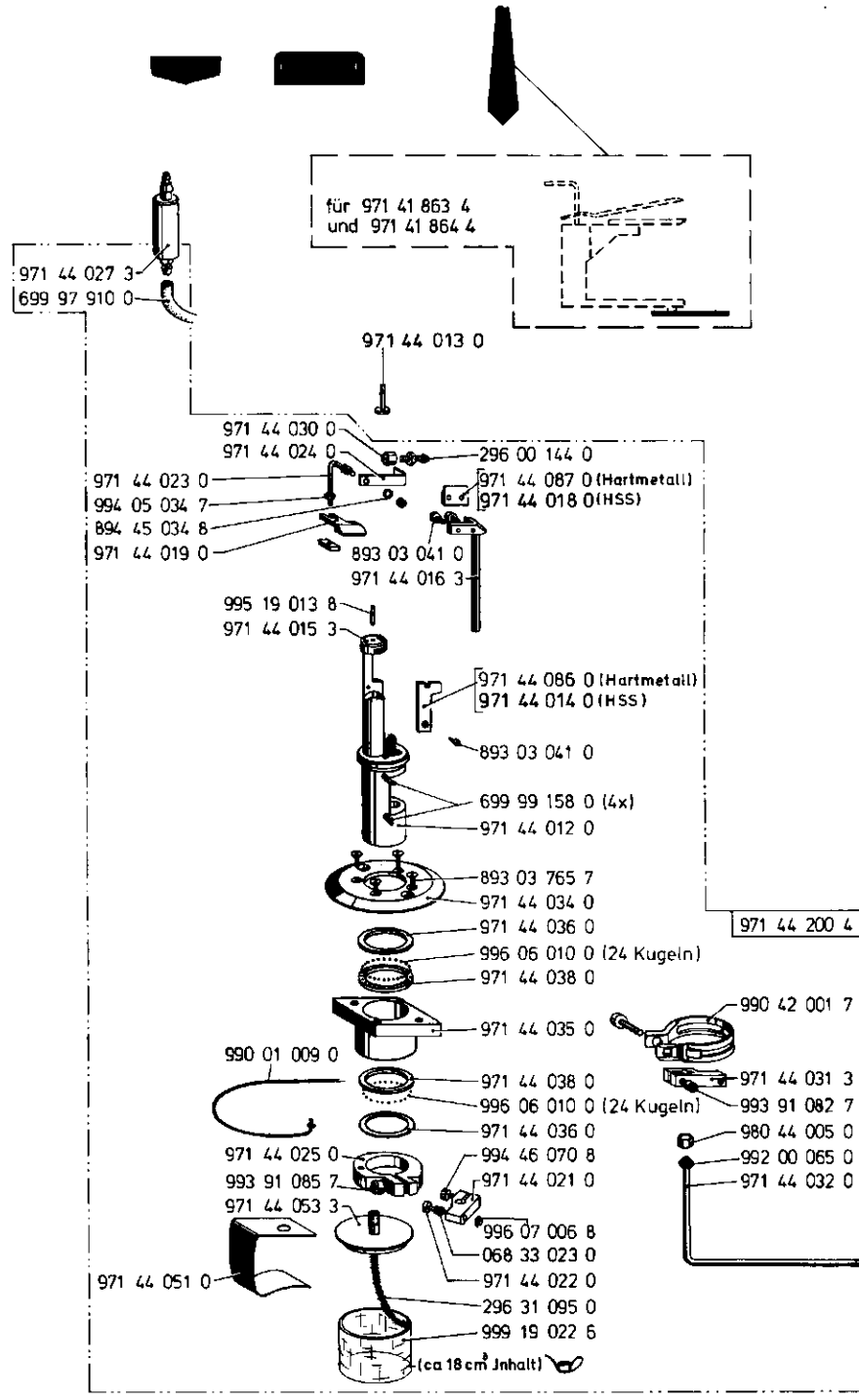

4.1

4.1

Stempelausführung
Design of metal punch
Poinçon
Punzon

971, 972,

Beschneiderteile auf Wunsch
trimmer parts on request
pièces de tachées pour dispositif de coupe à souhait
piezas del cabezal cortador a petición

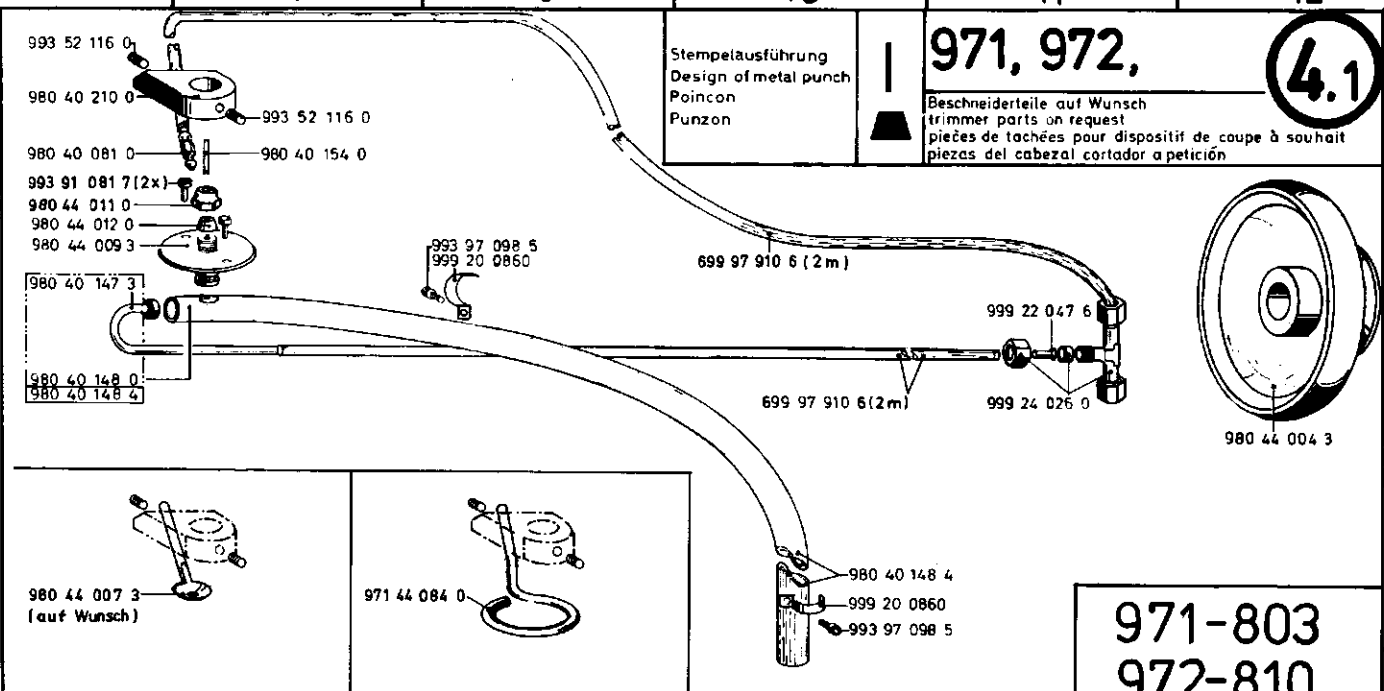

971-803
972-810

971,972

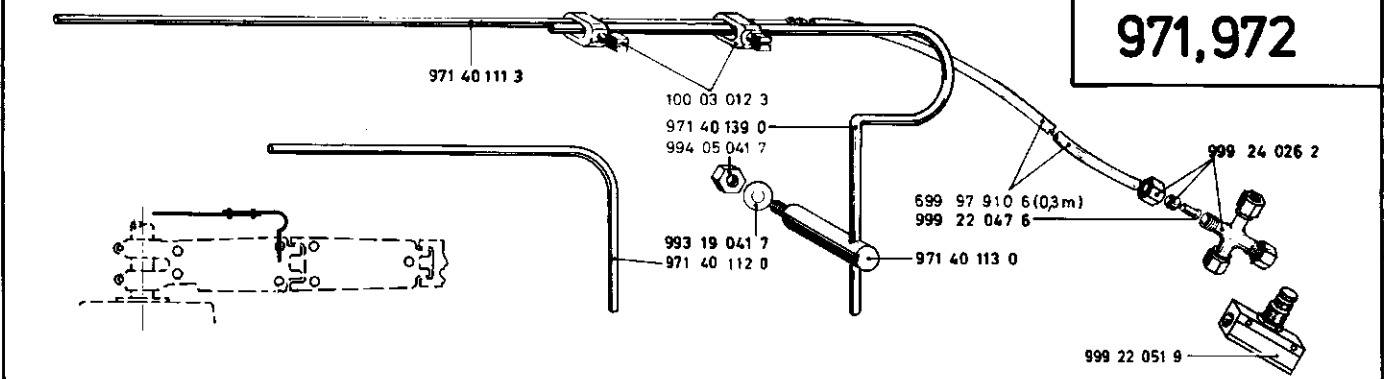

971,972

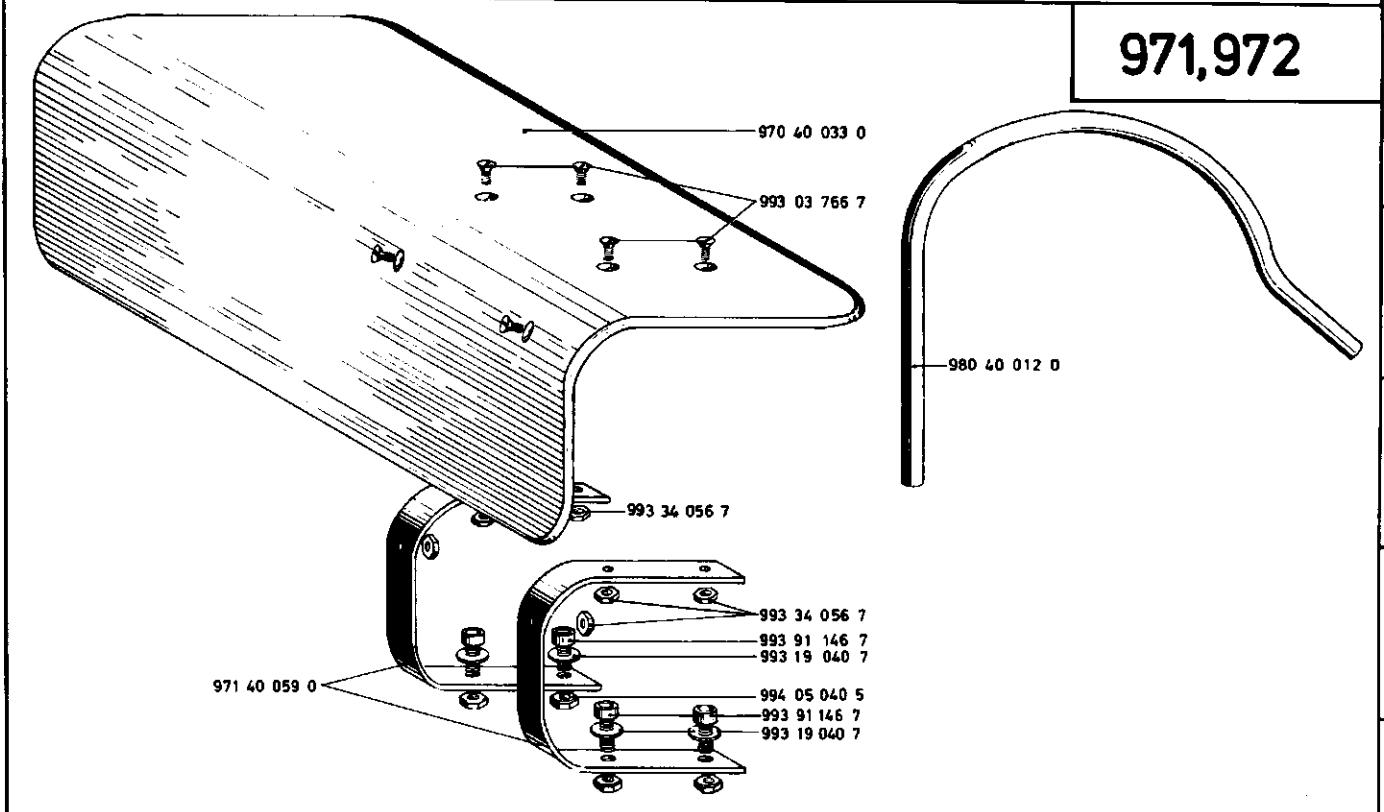

5 A

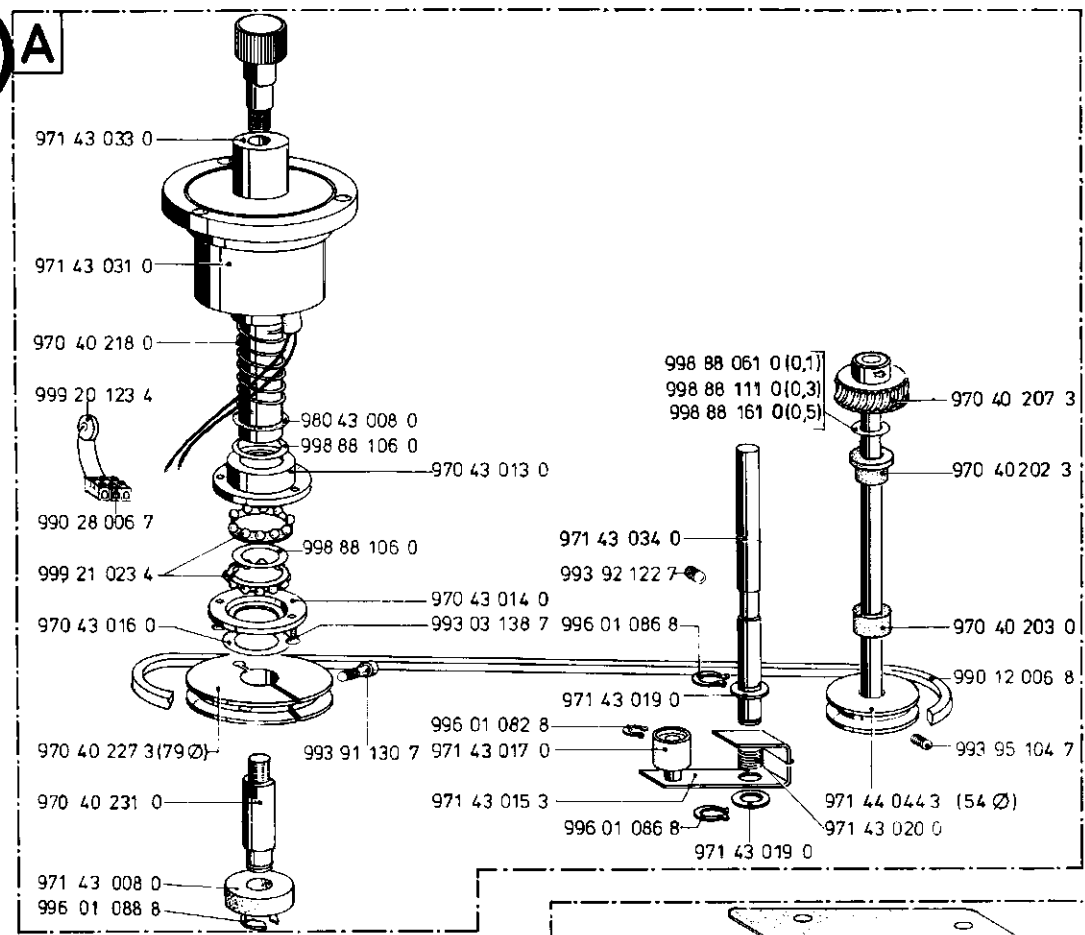

Einfachrolle
A+C=971 43 101 4

siehe auch „Laufrollen
und Keilriemenscheiben“
Bildtafel 6

5 A

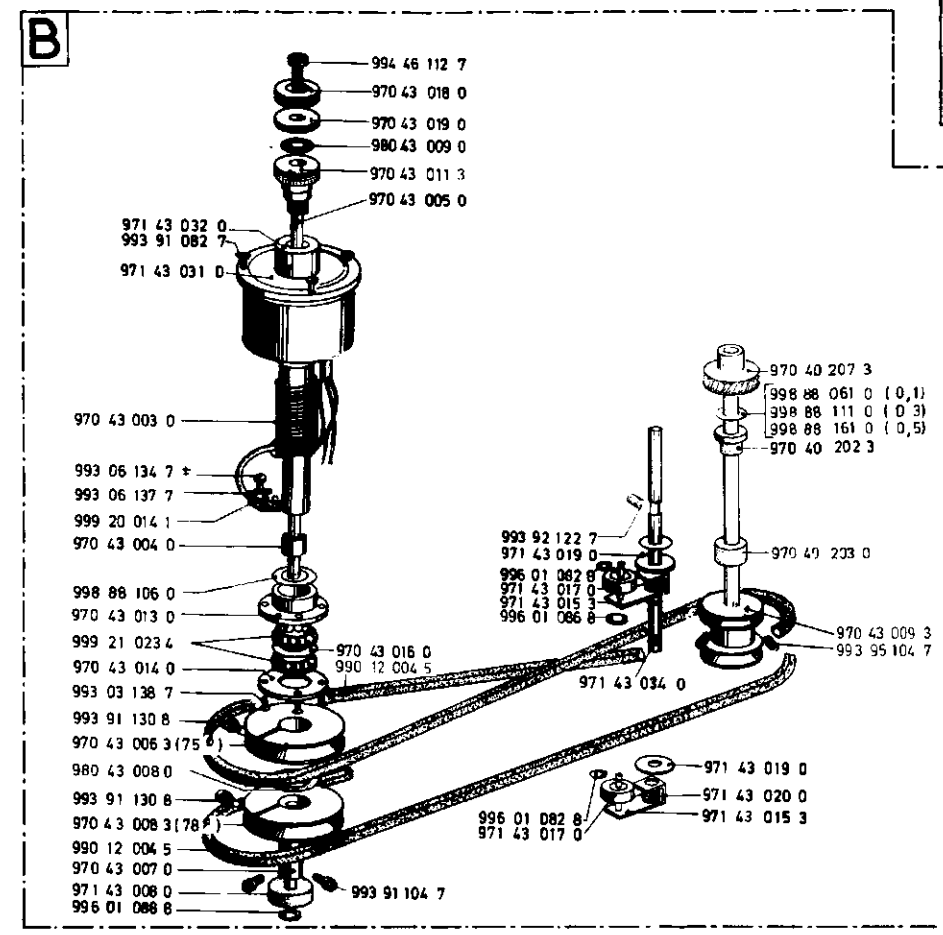

Doppelrolle
B+C=971 43 102 4

C

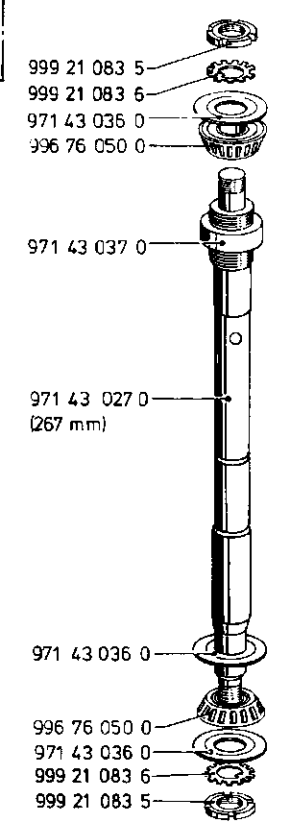
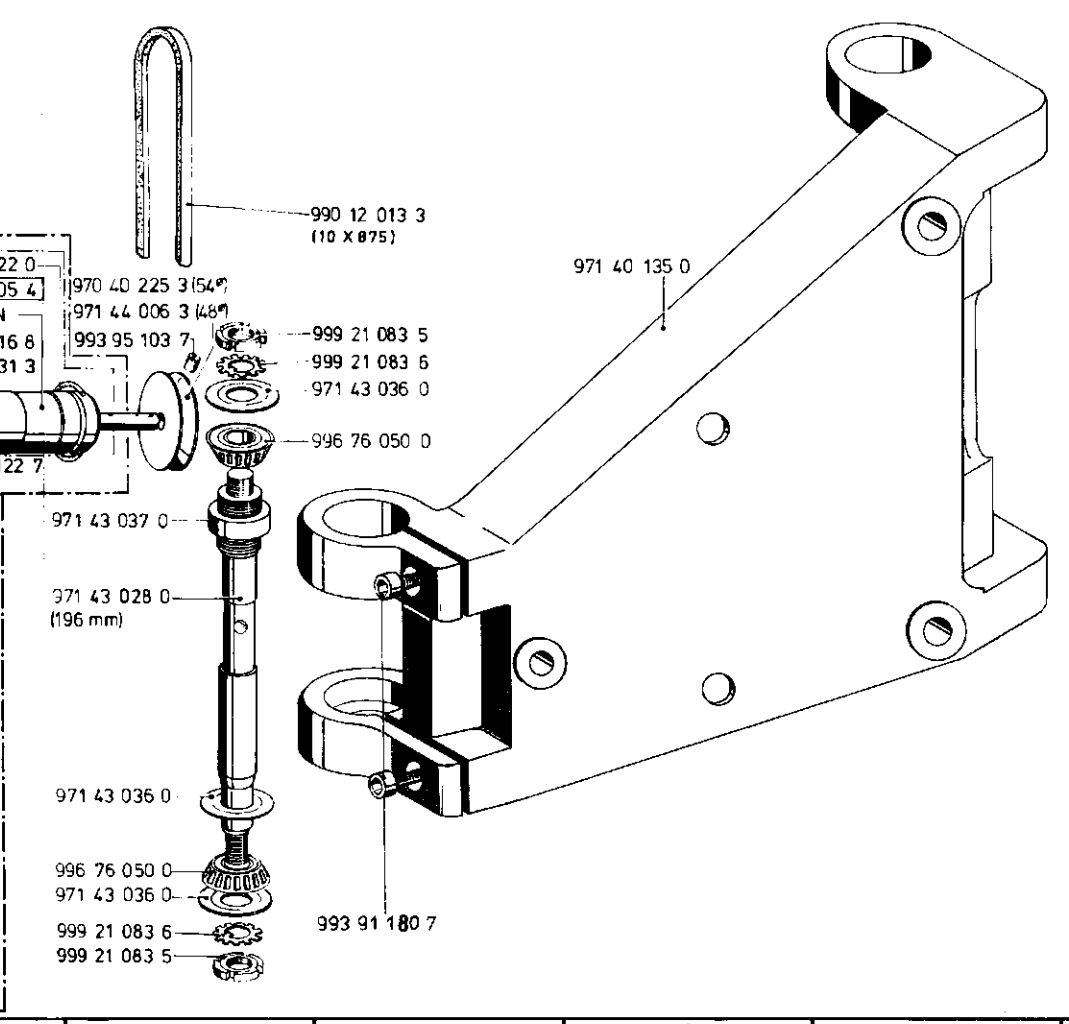
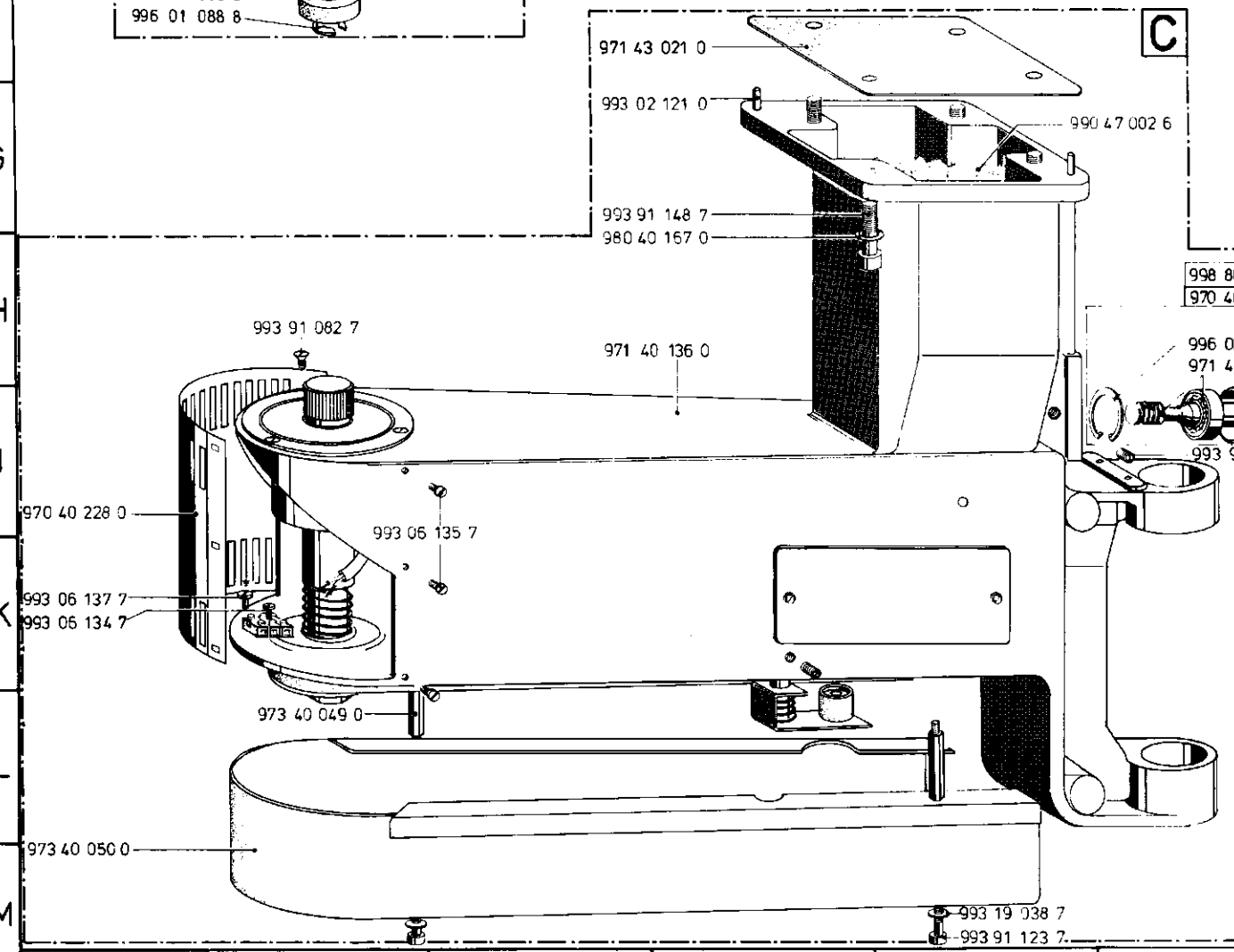

1 2 3 4 5 6 7 8 9 10 11 12													
						Keilriemenscheiben V-belt pulley poulie à courroie polea para correa trapezoidal						971, 972, 980	
D1		D2		D3		D5		D4					
980 44 004 3	52 ϕ	980 44 003 3	72 ϕ	971 44 006 3	48 ϕ	971 44 042 3	53 ϕ	971 44 043 3	66 ϕ				
196 00 006 0	65 ϕ	970 40 239 3	85 ϕ	970 40 225 3	54 ϕ	971 44 088 3	66 ϕ	971 44 089 3	62 ϕ				
		971 44 005 3	97 ϕ			971 44 045 3	72 ϕ	971 44 044 3	54 ϕ				
		971 44 004 3	110 ϕ			971 44 045 3	72 ϕ	971 44 044 3	54 ϕ				
		971 43 035 3	68 ϕ			970 40 227 3	79 ϕ	970 40 226 3	48 ϕ				
						970 40 227 3	79 ϕ	970 40 226 3	48 ϕ				
						971 44 088 3	66 ϕ	971 44 089 3	62 ϕ				
						971 44 081 3	53	971 44 089 3	62 ϕ				

SA = Schneidabstand cutting distance

Klasse Class	E..	SA (mm)	D6 Laufrolle Roller	D3	D4 Keilriemenscheiben V-belt pulley	D5	Keilriemen V-belt	Verwendung Use
971-800 -820 -822	K971 E1	3,5	971 44 003 0 ϕ 18	970 40 225 3	971 44 044 3	971 44 045 3	990 12 006 8	Beschneider trimmer
	E2	4,5	971 44 002 0 ϕ 16	971 44 006 3	971 44 044 3	971 44 045 3	990 12 006 8	
	E3	5,5	971 44 047 0 ϕ 14	970 40 225 3	971 44 089 3	971 44 088 3	990 12 006 8	
	E4	6,5	971 44 079 0 ϕ 12	971 44 006 3	971 44 089 3	971 44 088 3	990 12 006 8	
			970 40 230 0 ϕ 27	970 40 225 3	970 40 226 3	970 40 227 3	990 12 006 8	Nähmaschine sewing machine
971-801	E5	5,5	971 44 080 0 ϕ 14	970 40 225 3	971 44 089 3	971 44 088 3	990 12 006 8	Beschneider trimmer
			971 44 049 0 ϕ 12	970 40 225 3	971 44 089 3	971 44 081 3	990 12 005 4	Nähmaschine sewing machine
971-803	E6	2,5	971 44 048 0 ϕ 19	971 44 006 3	970 40 226 3	970 40 227 3	990 12 006 8	Beschneider trimmer
			971 44 049 0 ϕ 12	970 40 225 3	971 44 043 3	971 44 042 3	990 12 004 5	Nähmaschine sewing machine

Laufrollen Roller Poulie Roldana	Teilenummer Comp.number Num.de la pièce Numero de pieza	Abmessung mm Dimension mm Dimensión mm						SA (mm)	Klasse Class Classe	
	D6	A	B	C	D	E	F			
	971 44 079 0	58	39	19	12			6,5	971	972
	980 40 171 0	54	39	15	16			4,5	971	972
	971 44 002 0	58	39	19	16			4,5	971	972
	971 44 003 0	58	39	19	18			3,5	971	972
	971 44 046 0	51	35	14,5	12				971	972
	971 44 047 0	58	39	19	14			5,5	971	972
	971 44 048 0	58	39	19	19				971	972
	980 40 170 0	54	39	15	20			2,5	971	972
	970 40 230 0	54	39	15	27				971	972
	980 40 172 0	54	39	15	36				971	972
	980 40 173 0	64	49	15	16			4,5	980	
	980 40 176 0	64	49	15	18			3,5	980	
	980 40 174 0	64	49	15	20			2,5	980	
	980 40 177 0	64	49	15	27				980	
	980 40 175 0	64	49	15	36				980	
971 44 080 0	50	39	11	14			5,5	971	972	
	994 46 112 7								971	972
	970 43 018 0				27	5			971	972
	971 43 005 0	49	10	27					971	972
	994 46 112 7								971	972
	970 43 018 0				27	5	I		971	972
	970 43 019 0				27	5	II	ohne Flexi-nähguthalter	971	972
	970 43 011 3	30	9	27			III		971	972
	973 43 055 0				27	5	I			972
	973 43 056 0				27	5	II	mit Flexi-nähguthalter		972
	970 43 011 3	30	9	27			III			972
	970 44 001 0	58	40,5	7,5	14	5	5	5,5	971	972
	970 44 002 0	58	39,5	8,5	16	5	5	4,5	971	972
	970 43 012 0	58	39	9	18	5	5	3,5	971	972
	971 44 085 0	58	37	6	12	5	5	6,5	971	972

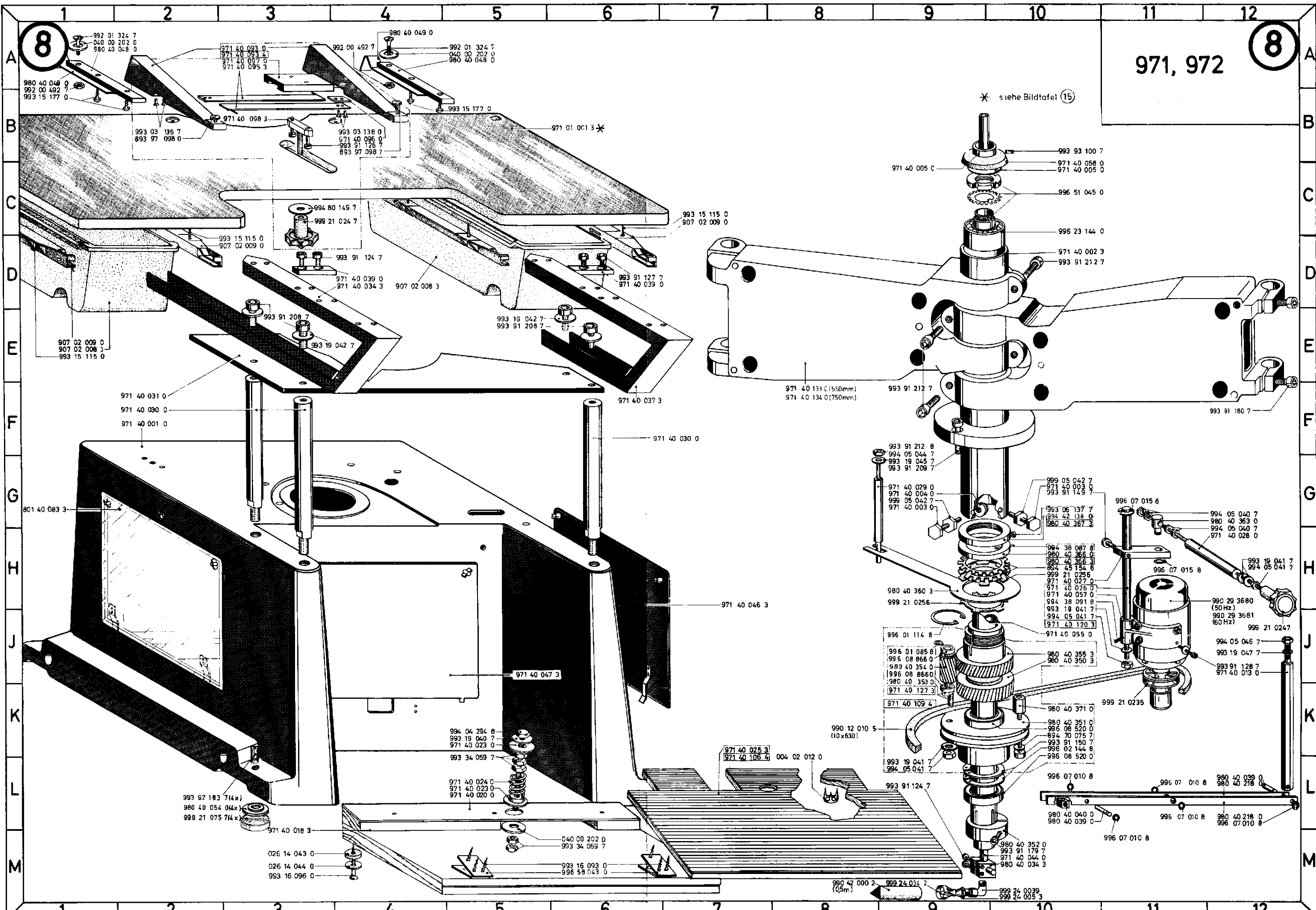

971, 972

* siehe Bildtafel (15)

* = Teile, die an dieser Stelle * fehlen, finden Sie auf der angehefteten Spezialliste
 Parts found missing at this place * are listed on the attached special list.
 Les pièces manquantes à cet endroit * sont indiqués dans la liste spéciale ci-jointe.
 Piezas que faltan en este lugar * se encuentran en la adjuntada lista especial.

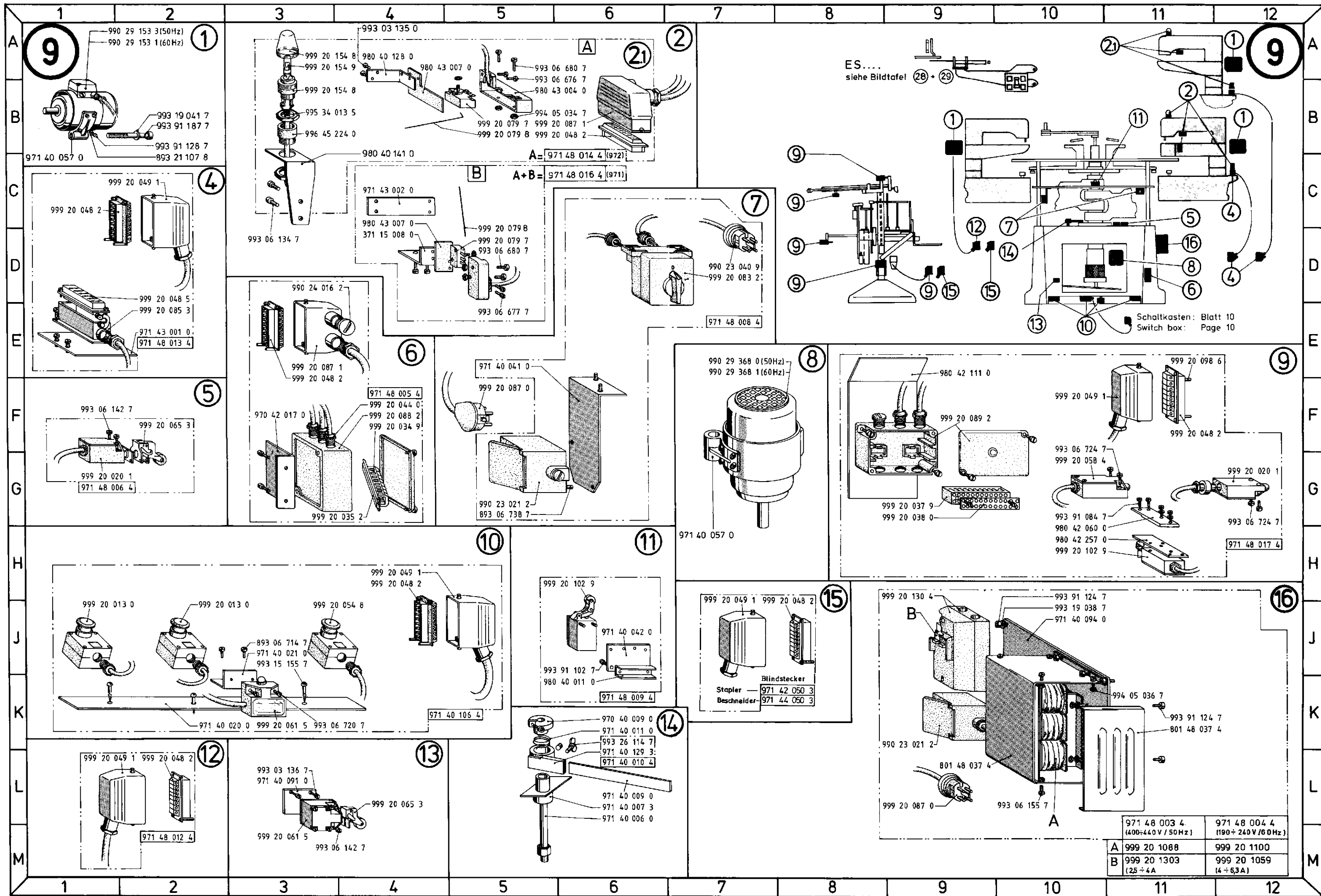

ES....
siehe Bildtafel 28 + 29

Schaltkasten: Blatt 10
Switch box: Page 10

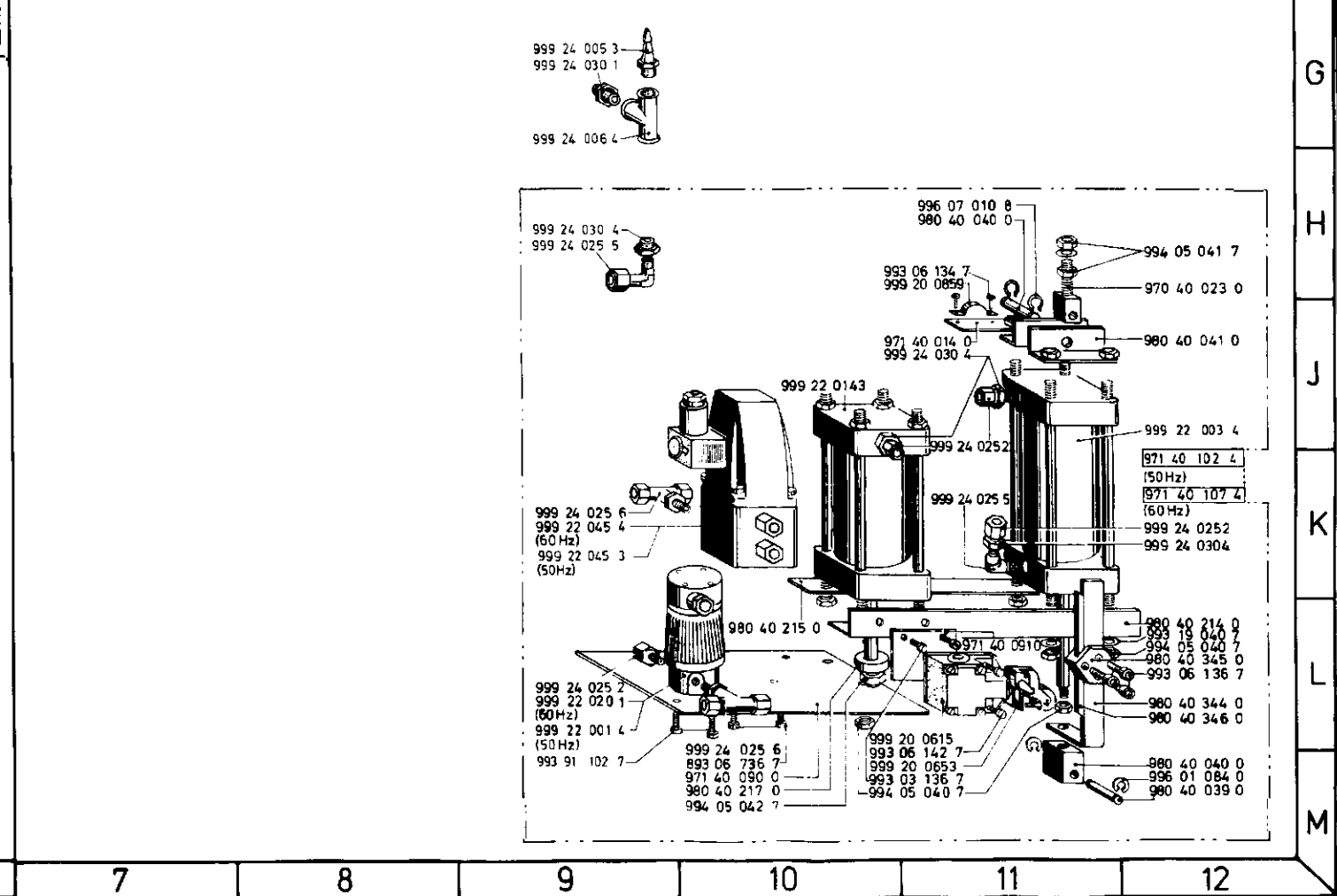
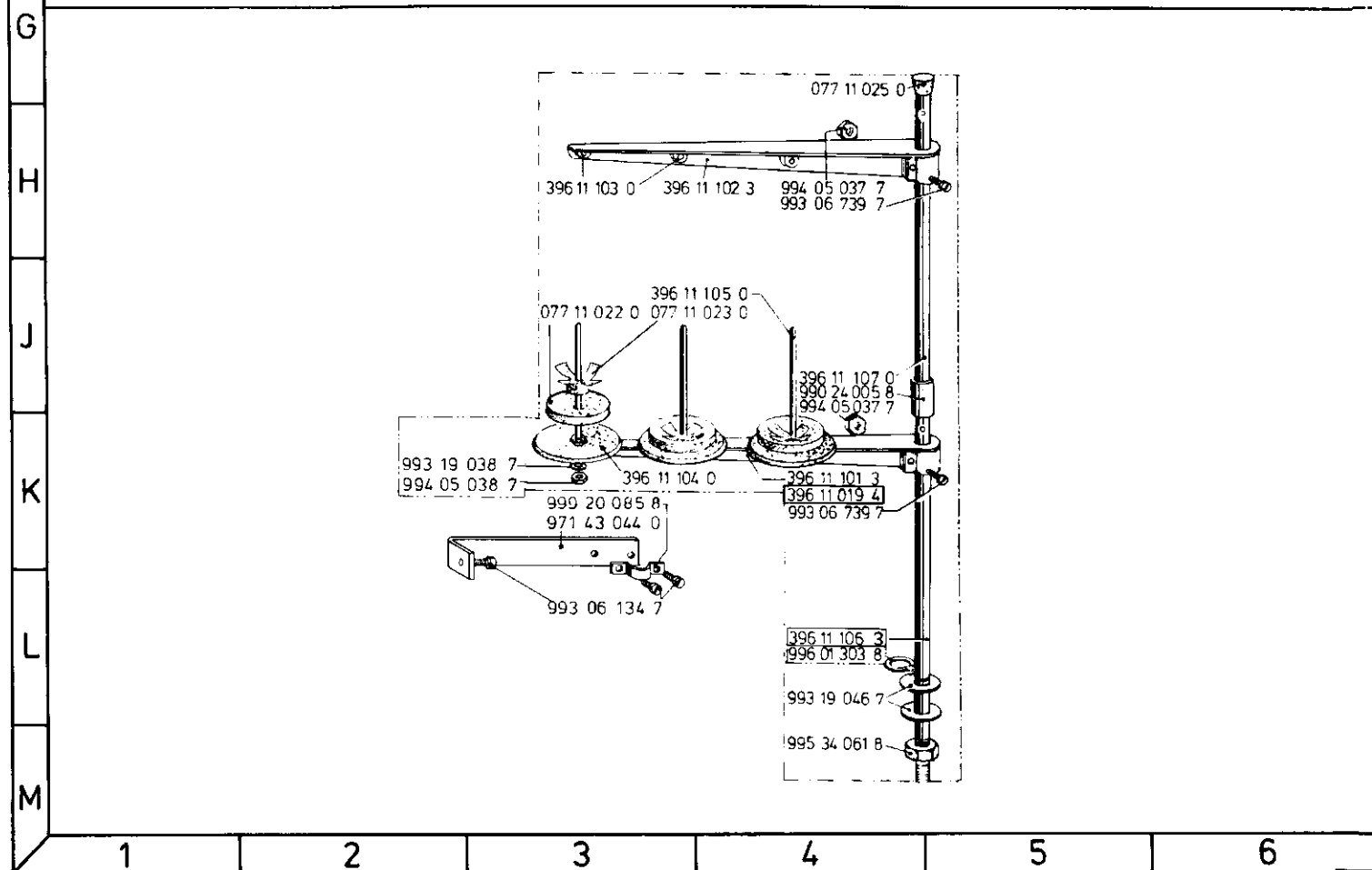
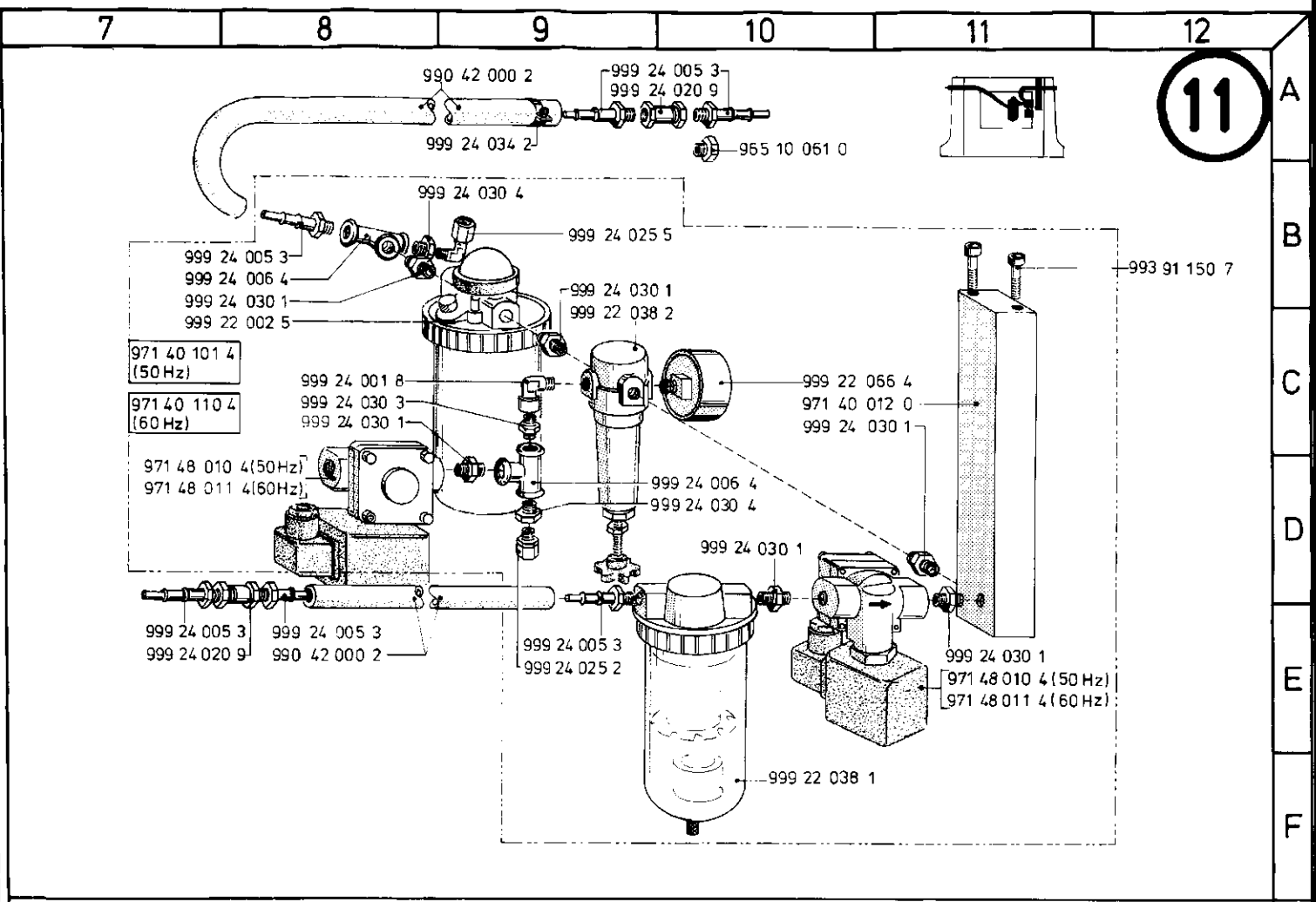
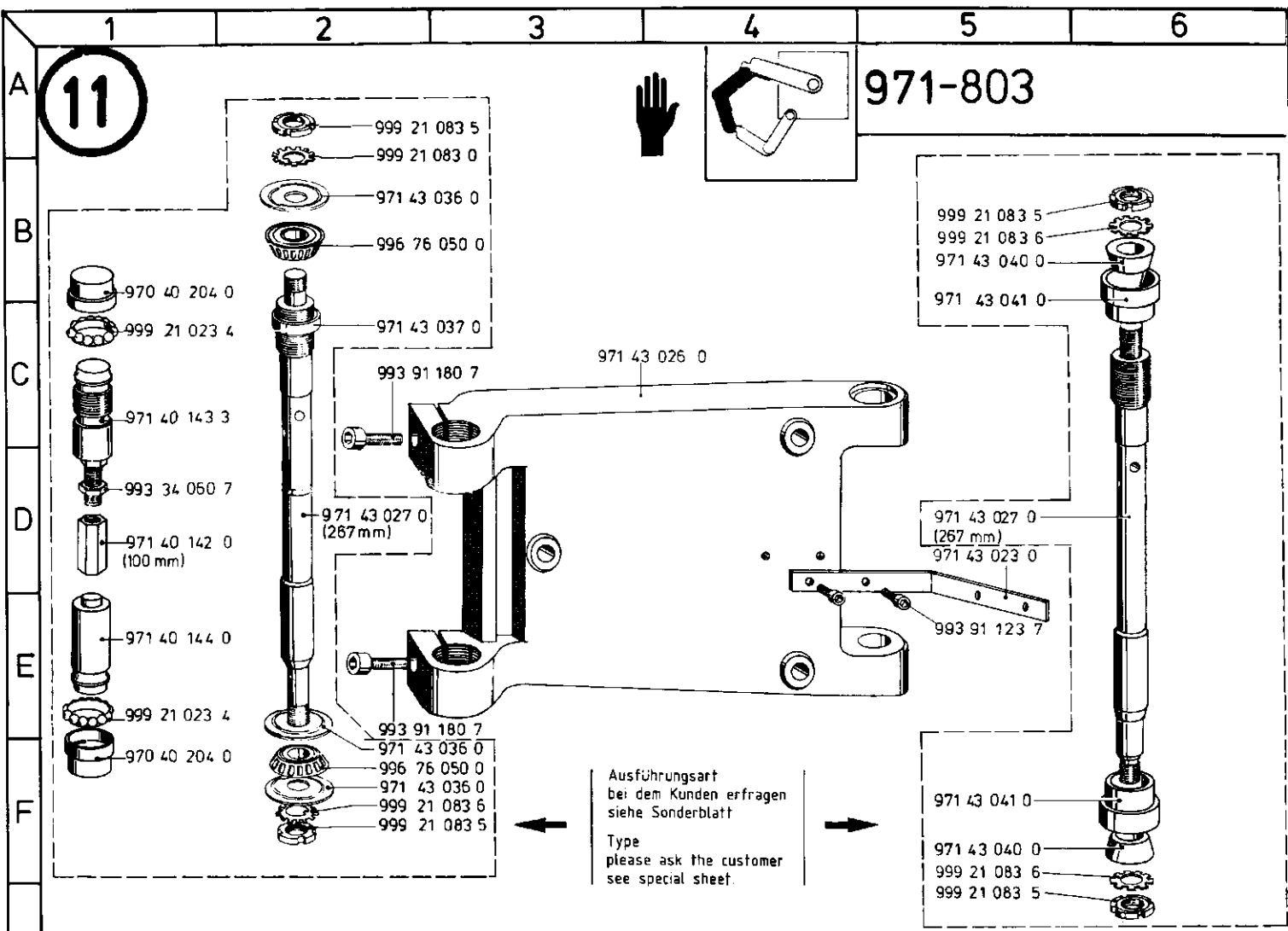

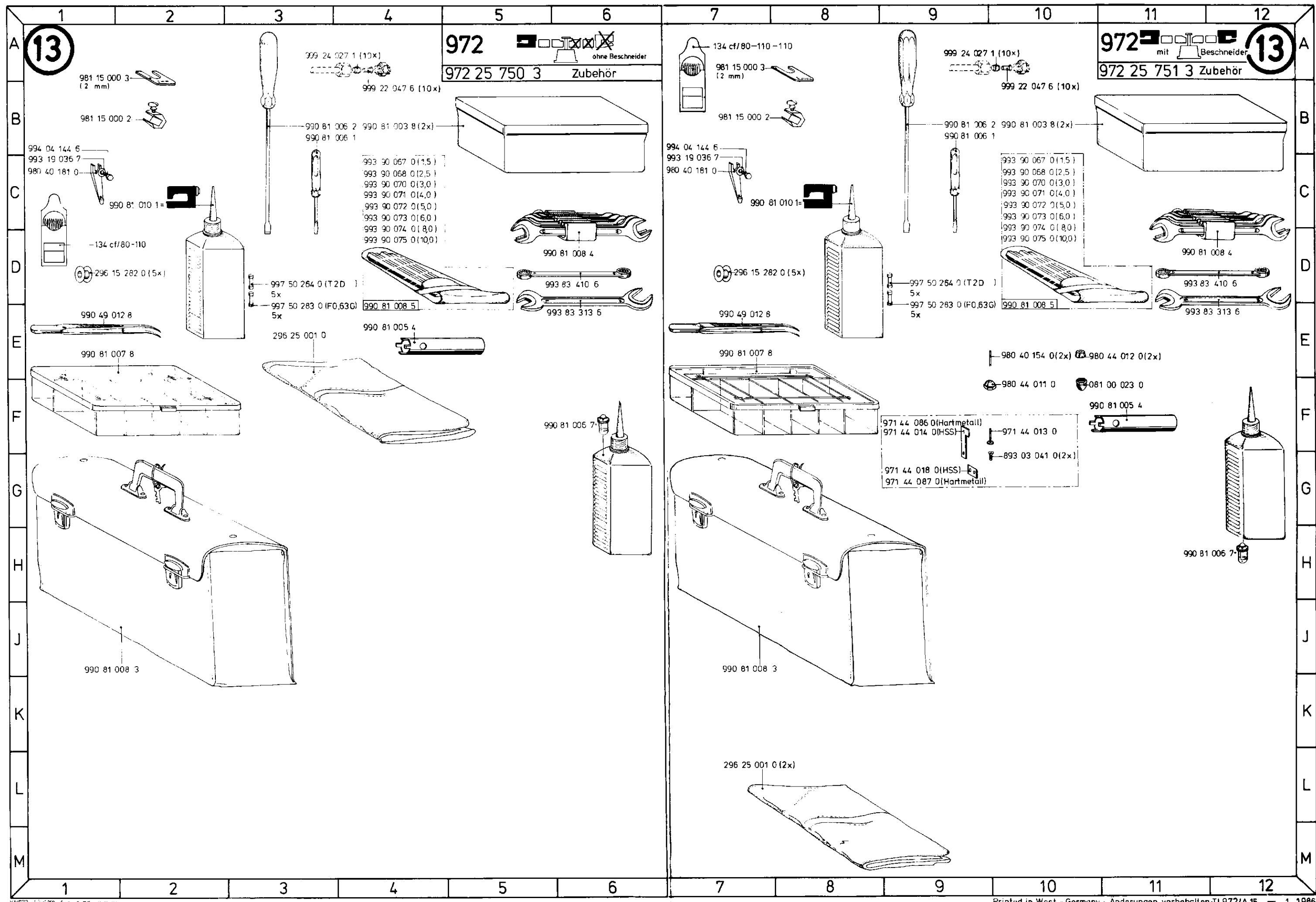

13

13

972 ohne Beschneider
 972 25 750 3 Zubehör

972 mit Beschneider
 972 25 751 3 Zubehör

981 15 000 3 (2 mm)

999 24 027 1 (10x)

134 cf/80-110
 981 15 000 3 (2 mm)

999 24 027 1 (10x)

999 22 047 6 (10x)

981 15 000 2

990 81 006 2 990 81 003 8 (2x)
 990 81 006 1

981 15 000 2

990 81 006 2 990 81 003 8 (2x)
 990 81 006 1

994 04 144 6
 993 19 036 7
 980 40 181 0

990 81 010 1

993 90 067 0 (1,5)
 993 90 068 0 (2,5)
 993 90 070 0 (3,0)
 993 90 071 0 (4,0)
 993 90 072 0 (5,0)
 993 90 073 0 (6,0)
 993 90 074 0 (8,0)
 993 90 075 0 (10,0)

994 04 144 6
 993 19 036 7
 980 40 181 0

990 81 010 1

993 90 067 0 (1,5)
 993 90 068 0 (2,5)
 993 90 070 0 (3,0)
 993 90 071 0 (4,0)
 993 90 072 0 (5,0)
 993 90 073 0 (6,0)
 993 90 074 0 (8,0)
 993 90 075 0 (10,0)

-134 cf/80-110

296 15 282 0 (5x)

997 50 264 0 (T2D) 5x
 997 50 283 0 (F0,63G) 5x

990 81 008 5

990 81 008 4

993 83 410 6

993 83 313 6

296 15 282 0 (5x)

997 50 264 0 (T2D) 5x
 997 50 283 0 (F0,63G) 5x

990 81 008 5

990 81 008 4

993 83 410 6

993 83 313 6

990 49 012 8

296 25 001 0

990 81 005 4

990 49 012 8

990 81 007 8

980 40 154 0 (2x) 980 44 012 0 (2x)

980 44 011 0

081 00 023 0

990 81 005 4

990 81 007 8

990 81 008 3

990 81 006 7

971 44 086 0 (Hartmetall)
 971 44 014 0 (HSS)
 971 44 018 0 (HSS)
 971 44 087 0 (Hartmetall)

971 44 013 0

893 03 041 0 (2x)

990 81 006 7

990 81 008 3

990 81 008 3

296 25 001 0 (2x)

pneumatische Schere

Umbau von Kl. 971-820 in Kl. 971-822

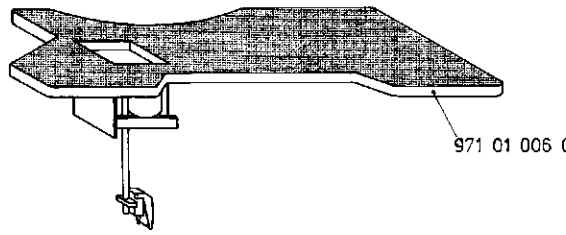

971 01 006 0

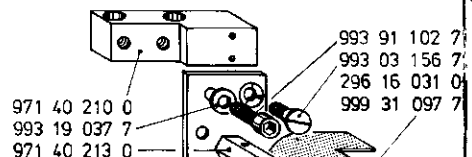

971 40 210 0
993 19 037 7
971 40 213 0
993 91 102 7
993 03 156 7
296 16 031 0
999 31 097 7

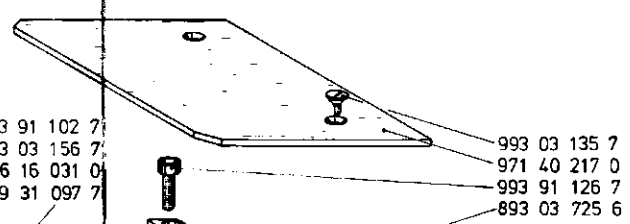

993 03 135 7
971 40 217 0
993 91 126 7
893 03 725 6

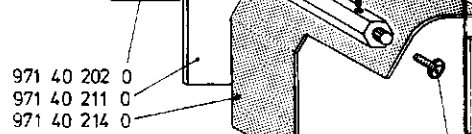

971 40 202 0
971 40 211 0
971 40 214 0

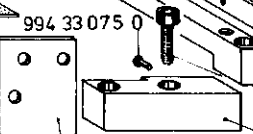

994 33 075 0



971 40 240 0

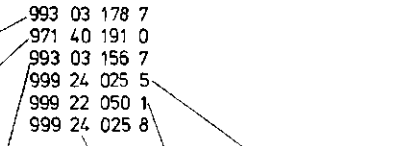

993 03 178 7
971 40 191 0
993 03 156 7
999 24 025 5
999 22 050 1
999 24 025 8

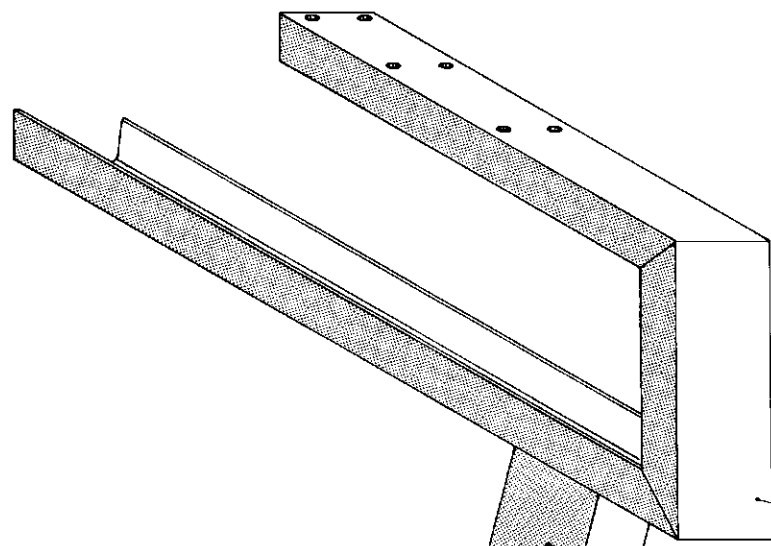

971 40 220 3
993 91 122 7
999 24 025 5
999 22 051 9
999 24 030 2
999 22 072 7

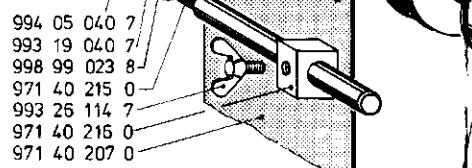

994 05 040 7
993 19 040 7
998 99 023 8
971 40 215 0
993 25 114 7
971 40 216 0
971 40 207 0

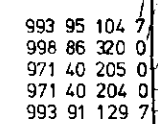

993 95 104 7
998 86 320 0
971 40 205 0
971 40 204 0
993 91 129 7

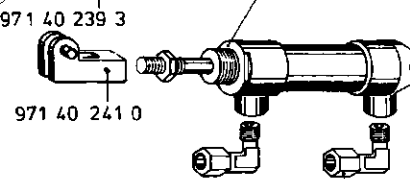

971 40 239 3
999 22 067 4
068 00 625 0
996 07 011 8
971 40 196 0
893 03 725 6

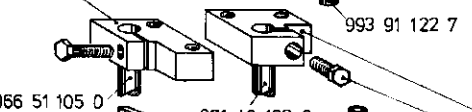

993 91 122 7
999 22 065 4
973 46 102 0
971 40 192 3
994 04 212 7
993 91 127 7
994 05 038 7
993 27 133 7
971 40 198 0
067 00 930 0
971 40 195 0
971 40 197 0
999 23 024 8
971 40 194 3
802 41 559 0
996 07 008 8
973 45 229 0
993 06 146 7
999 22 072 3
999 24 030 2
999 24 030 5
999 24 030 2
999 24 027 3
999 22 051 9
999 24 025 8
699 97 910 6
999 22 047 6

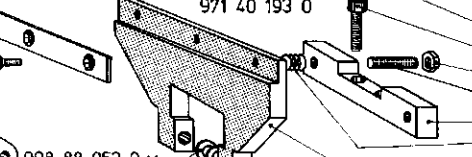

999 24 025 5
994 05 038 7
994 04 214 7
993 06 100 7
999 22 067 1

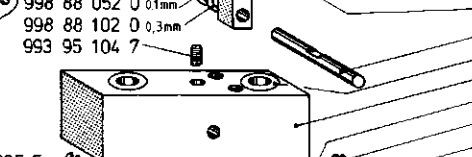

971 40 201 0
993 19 038 7
081 00 475 0
973 45 228 0

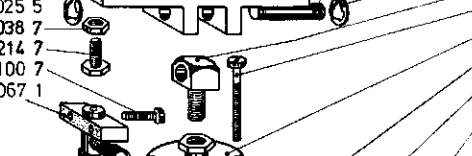

999 24 025 2
999 24 025 6
802 41 559 0
996 07 008 8
971 40 200 0
993 91 130 7

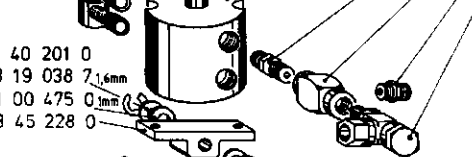

994 05 037 7
994 05 038 7
971 40 199 3
999 24 034 4
966 51 105 0
971 40 207 0
993 19 037 7
994 04 178 7
993 91 125 7
971 40 219 3
993 91 123 7

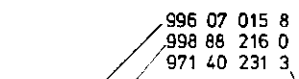

996 07 015 8
998 88 216 0
971 40 231 3



999 22 059 7
999 22 059 6
893 02 199 0
993 91 127 7
971 40 227 3

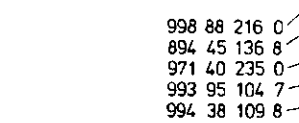

998 88 216 0
894 45 136 8
971 40 235 0
993 95 104 7
994 38 109 8

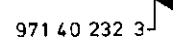

971 40 232 3

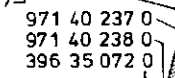

993 91 123 7
971 40 237 0
971 40 238 0
396 35 072 0

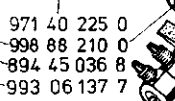

971 40 225 0
998 88 210 0
894 45 036 8
993 06 137 7

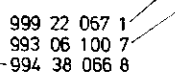

999 22 067 1
993 06 100 7
994 38 066 8

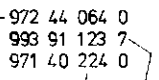

972 44 064 0
993 91 123 7
971 40 224 0



993 91 126 7
971 40 228 0

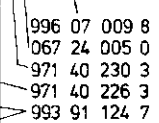

996 07 009 8
067 24 005 0
971 40 230 3
971 40 226 3
993 91 124 7

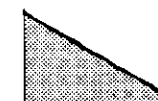

971 40 241 0

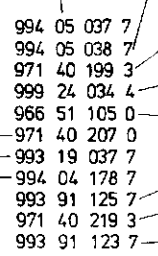

994 05 037 7
994 05 038 7
971 40 199 3
999 24 034 4
966 51 105 0
971 40 207 0
993 19 037 7
994 04 178 7
993 91 125 7
971 40 219 3
993 91 123 7

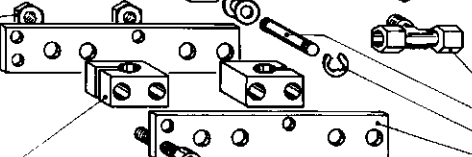

999 24 025 2
999 24 025 6
802 41 559 0
996 07 008 8
971 40 200 0
993 91 130 7

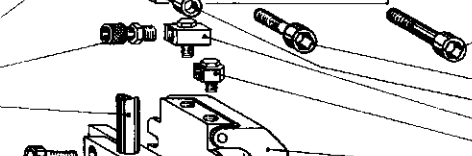

993 91 128 7
993 91 110 7
999 24 036 6
999 24 036 5
999 22 071 2

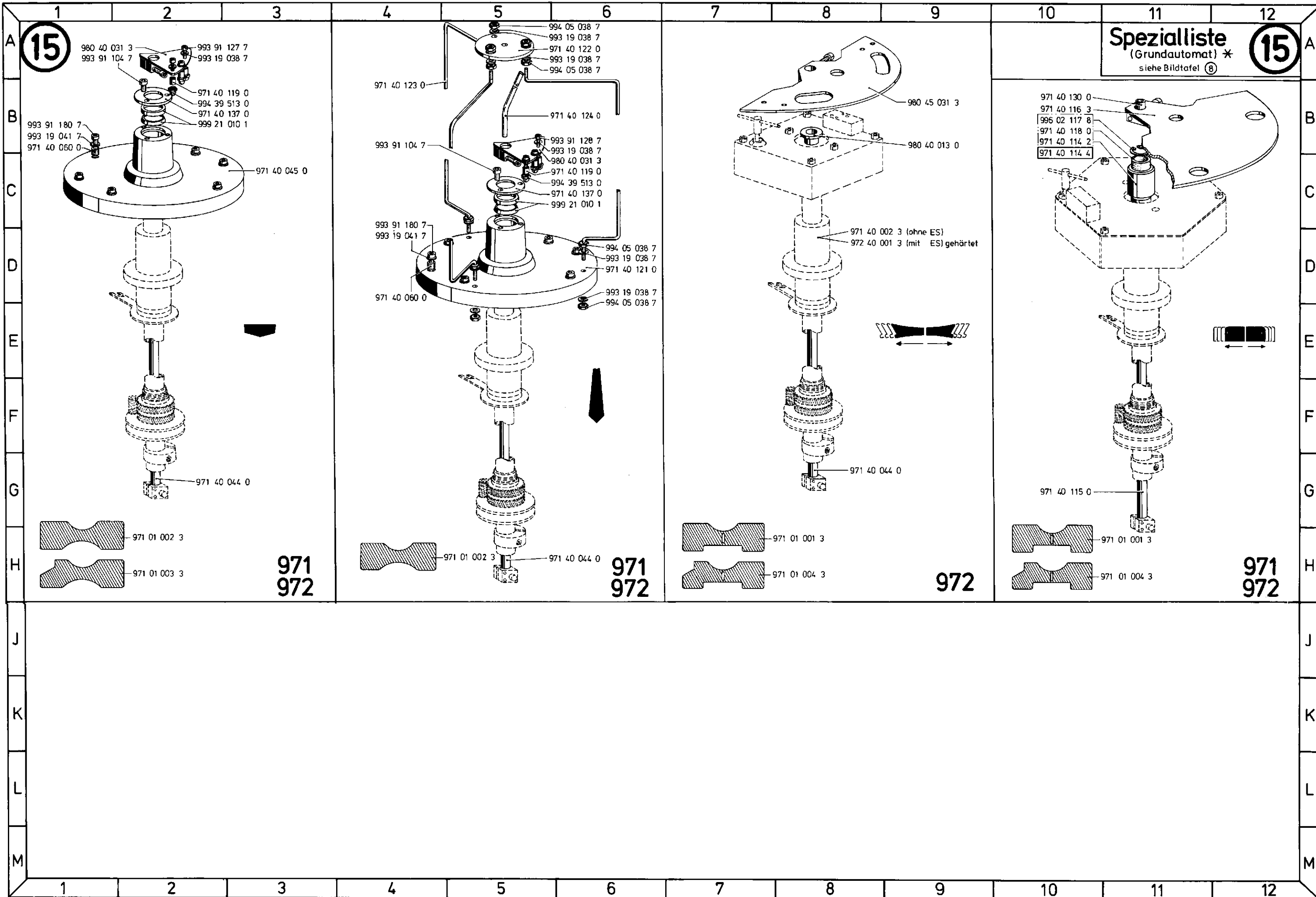

15

Spezialliste
(Grundautomat) *
siehe Bildtafel 8

15

980 40 031 3
993 91 104 7

993 91 127 7
993 19 038 7

971 40 119 0
994 39 513 0
971 40 137 0
999 21 010 1

993 91 180 7
993 19 041 7
971 40 060 0

971 40 045 0

971 40 044 0

971 01 002 3

971 01 003 3

971
972

994 05 038 7
993 19 038 7
971 40 122 0
993 19 038 7
994 05 038 7

971 40 123 0

971 40 124 0

993 91 104 7
993 91 128 7
993 19 038 7
980 40 031 3
971 40 119 0
994 39 513 0
971 40 137 0
999 21 010 1

993 91 180 7
993 19 041 7

994 05 038 7
993 19 038 7
971 40 121 0

993 19 038 7
994 05 038 7

971 40 060 0

971 01 002 3

971 40 044 0

971
972

980 45 031 3

980 40 013 0

971 40 002 3 (ohne ES)
972 40 001 3 (mit ES) gehärtet



971 40 044 0

971 01 001 3

971 01 004 3

972

971 40 130 0
971 40 116 3
996 02 117 8
971 40 118 0
971 40 114 2
971 40 114 4

971 40 115 0

971 01 001 3

971 01 004 3

971
972

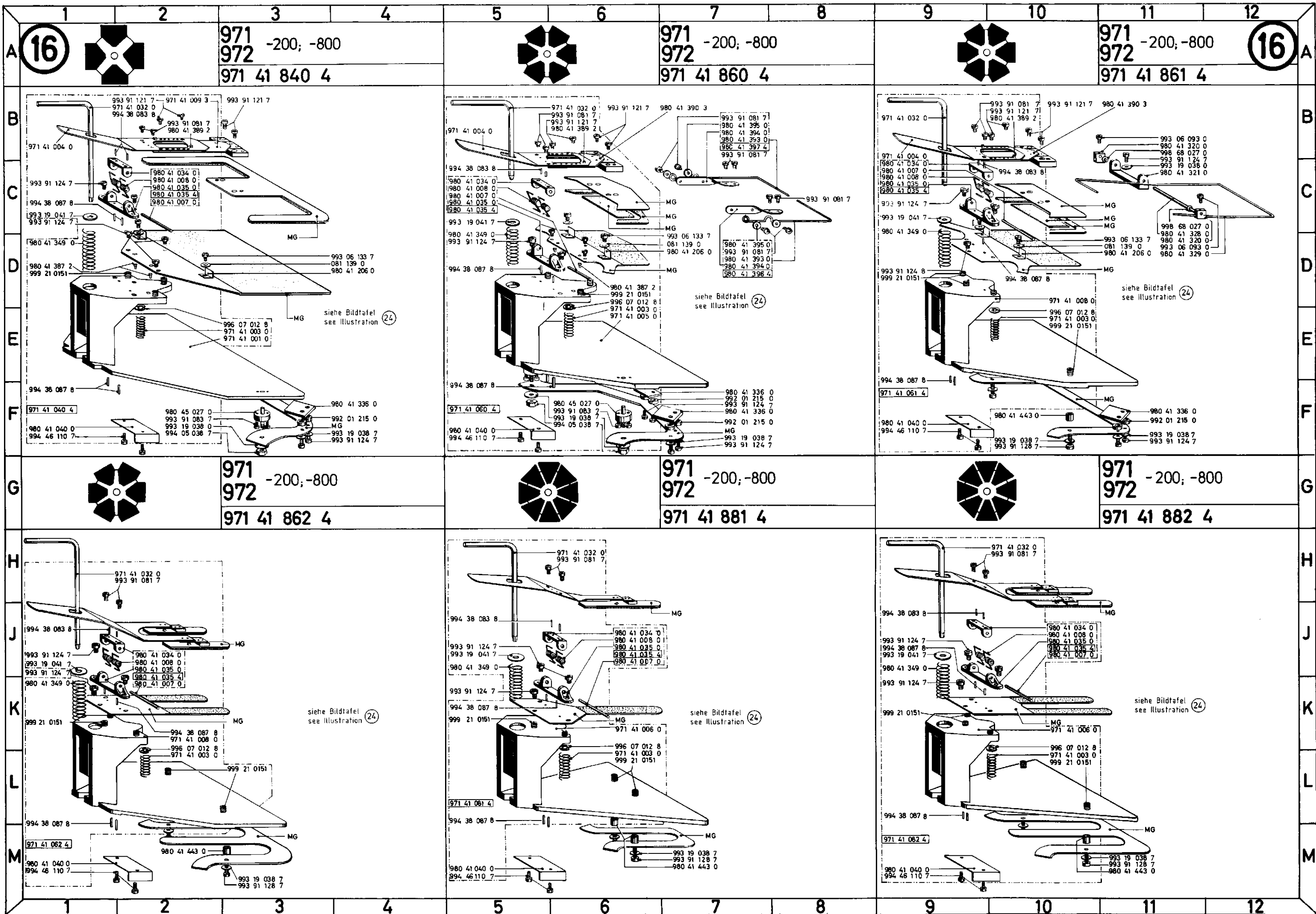

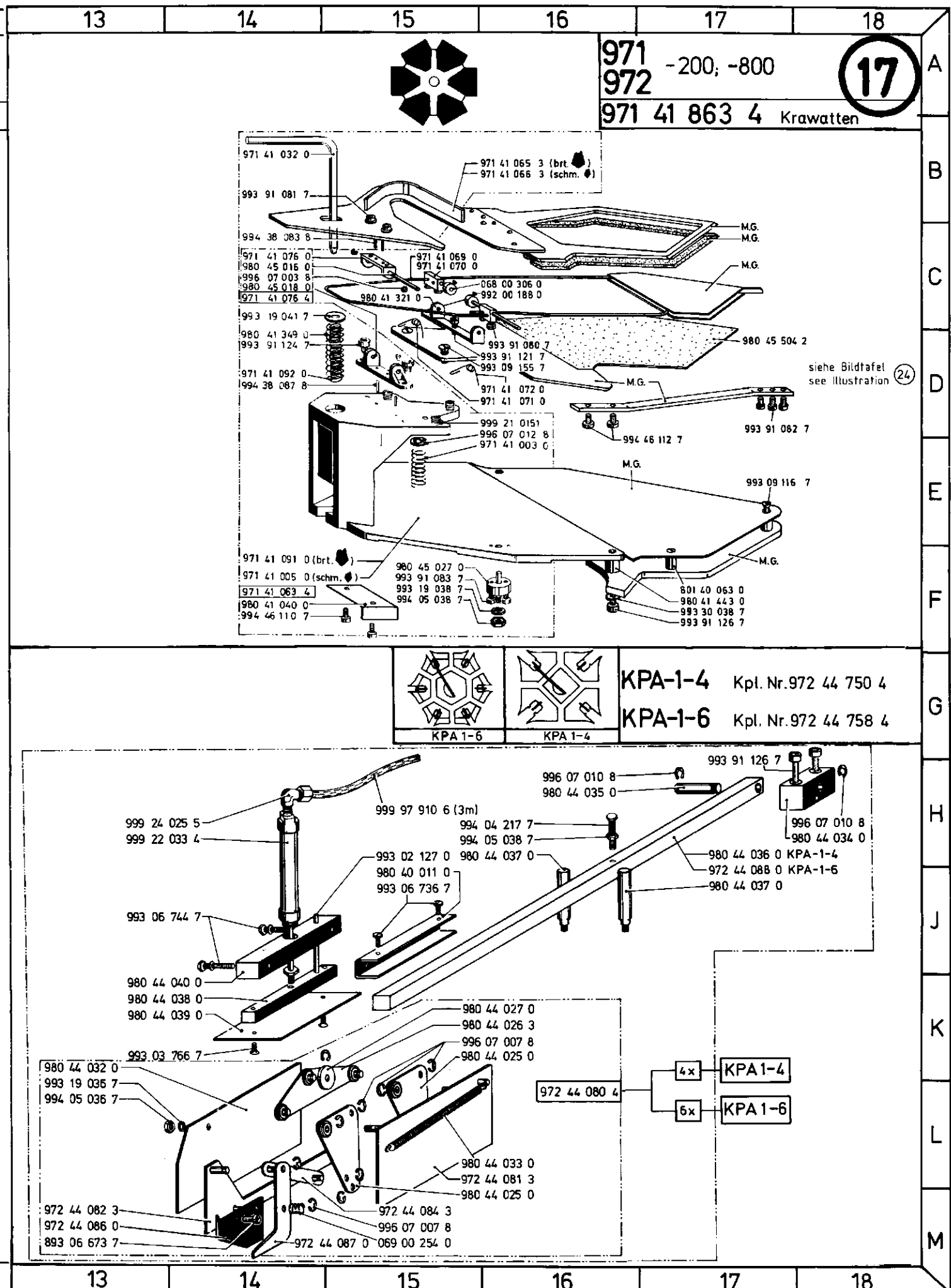
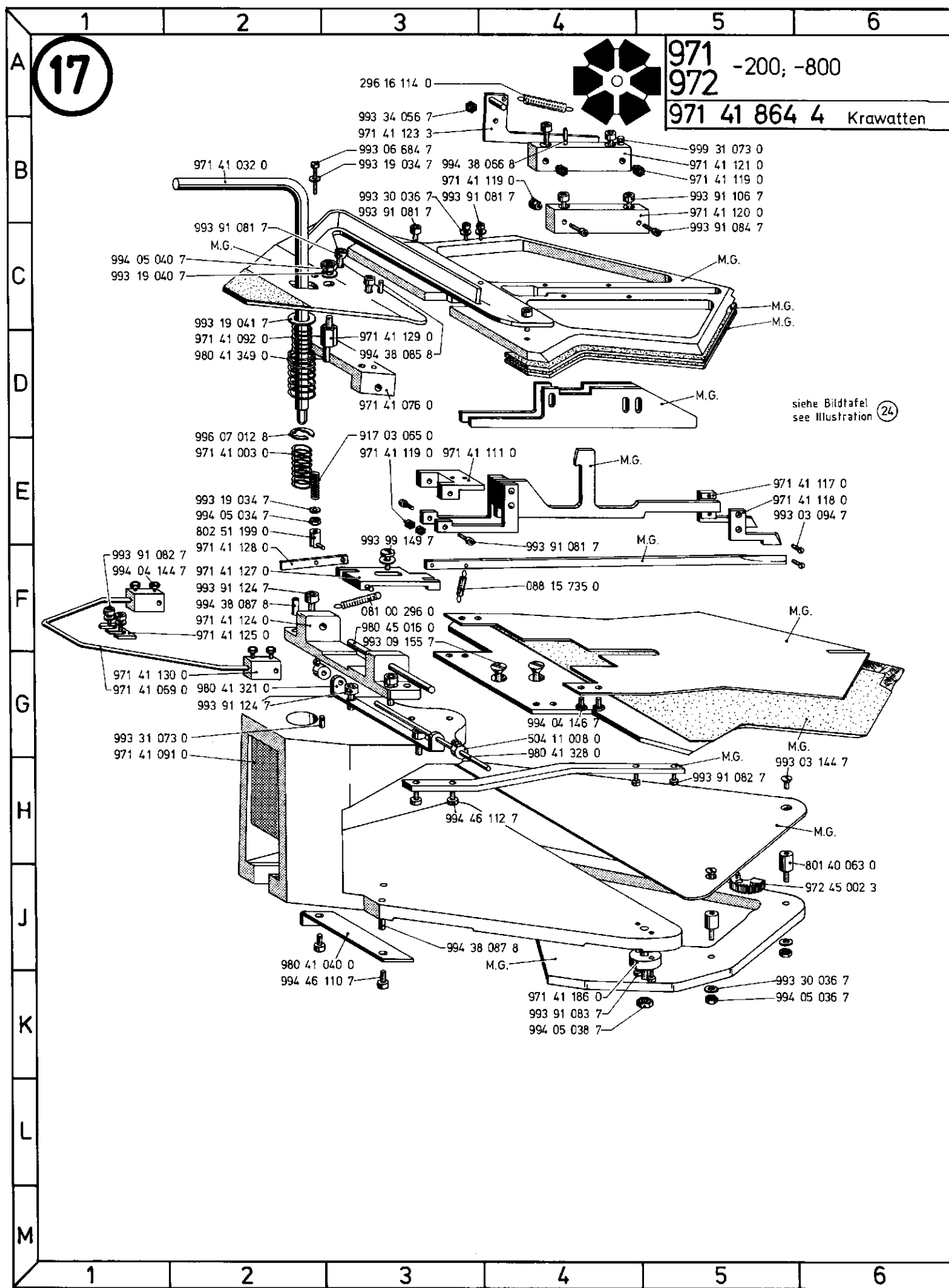

17.1

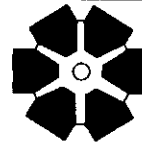

971
972 -200; -800
971 41 866 4 Krawatten

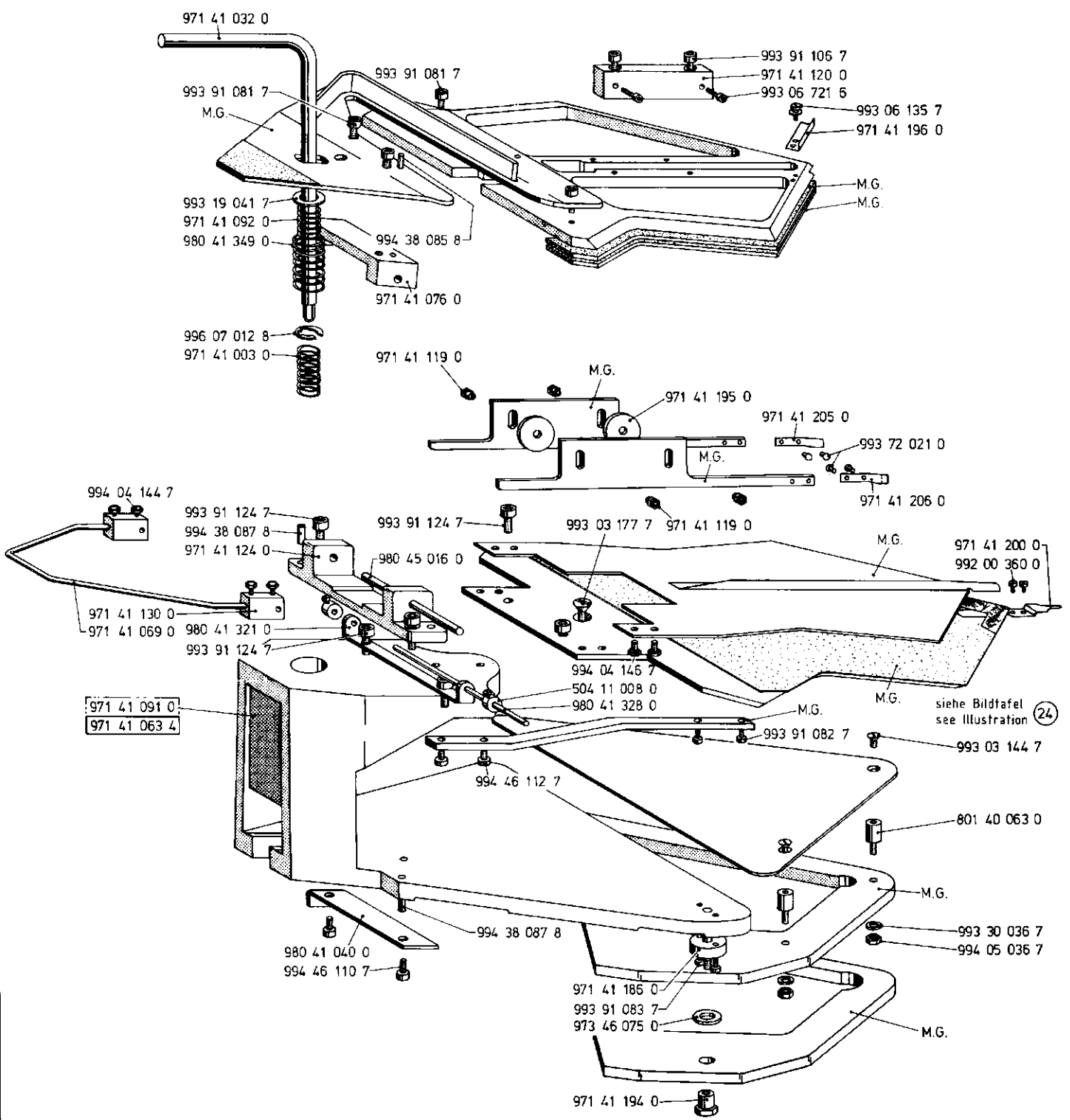

siehe Bildtafel 24
see illustration 24

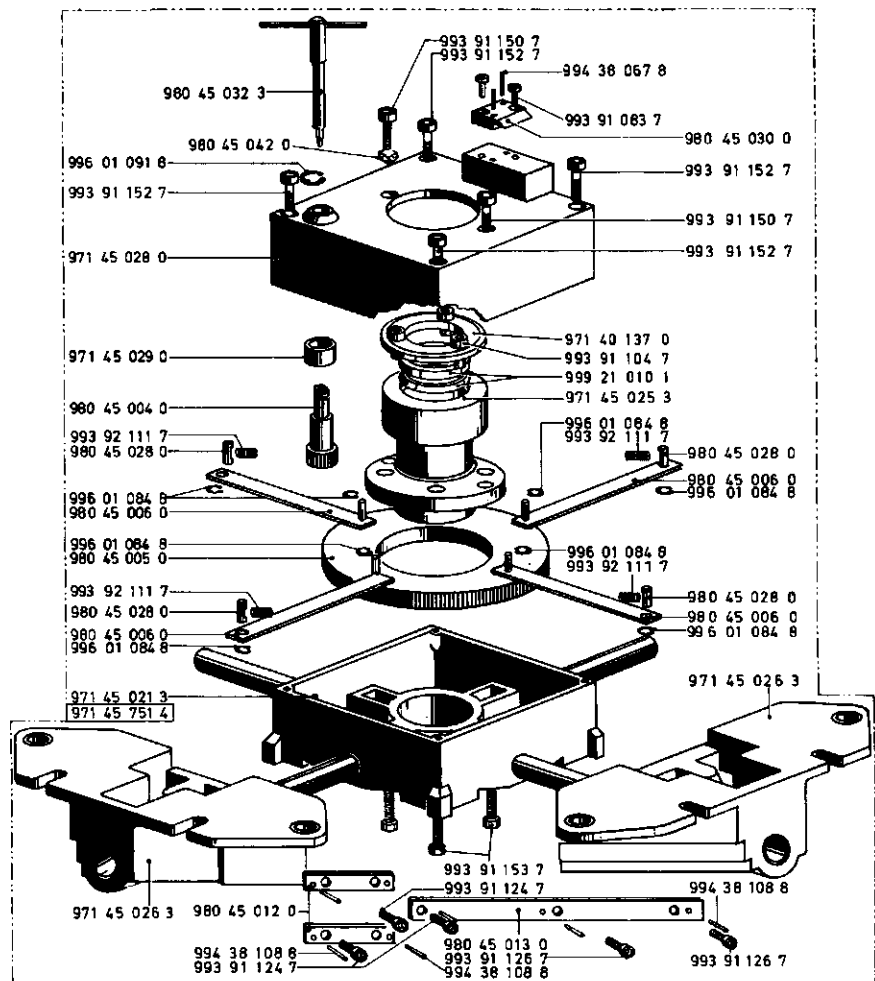

Nur für
Only for
Seulement pour
Solo per

972 ESI-ES3
972 ESI-ES3
972 ESI-ES3
972 ESI-ES3

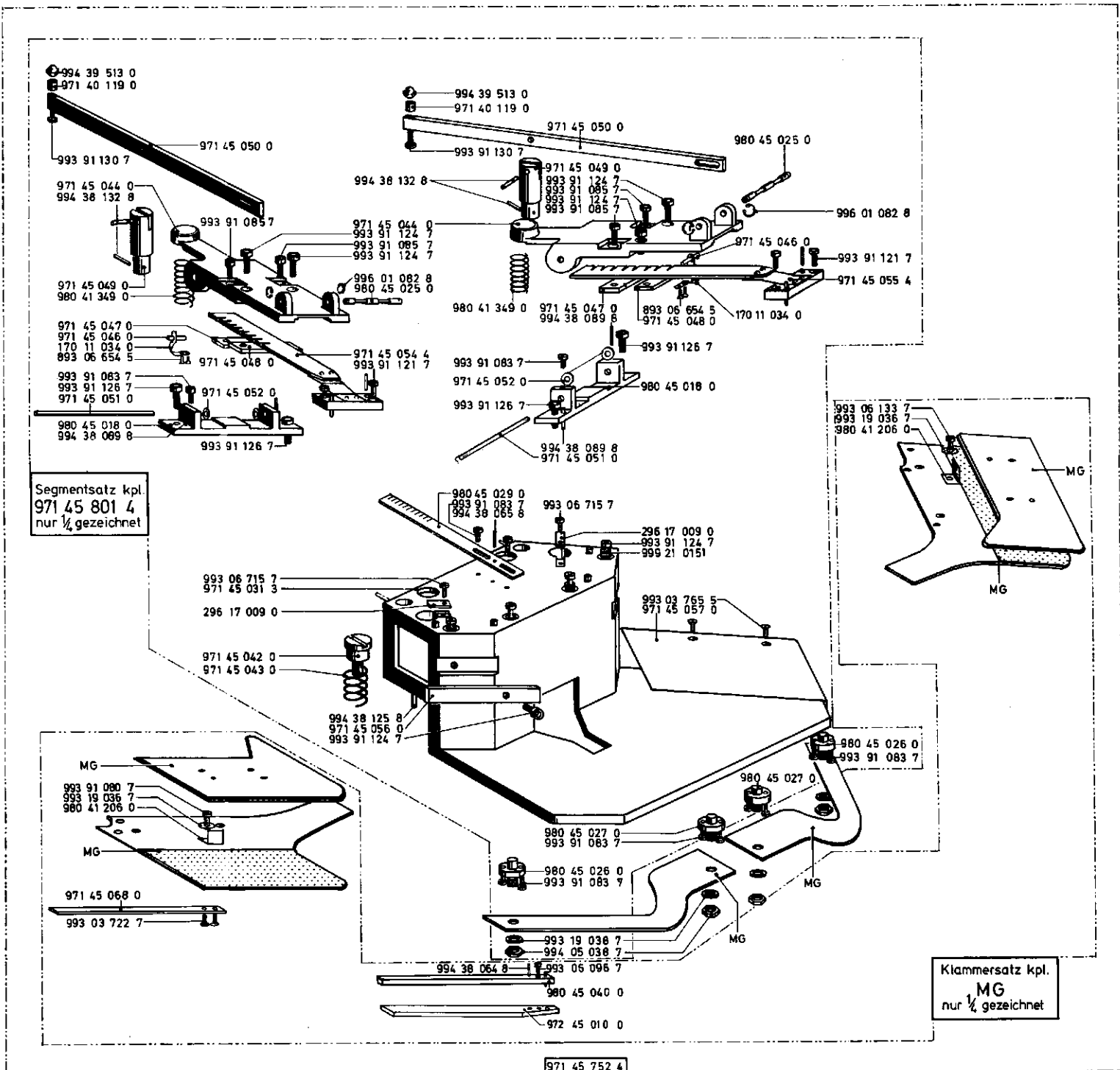
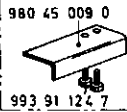
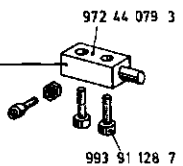

Segmentsatz kpl.
971 45 801 4
nur 1/2 gezeichnet

Klammersatz kpl.
MG
nur 1/2 gezeichnet

siehe Bildtafel
see illustration (24)

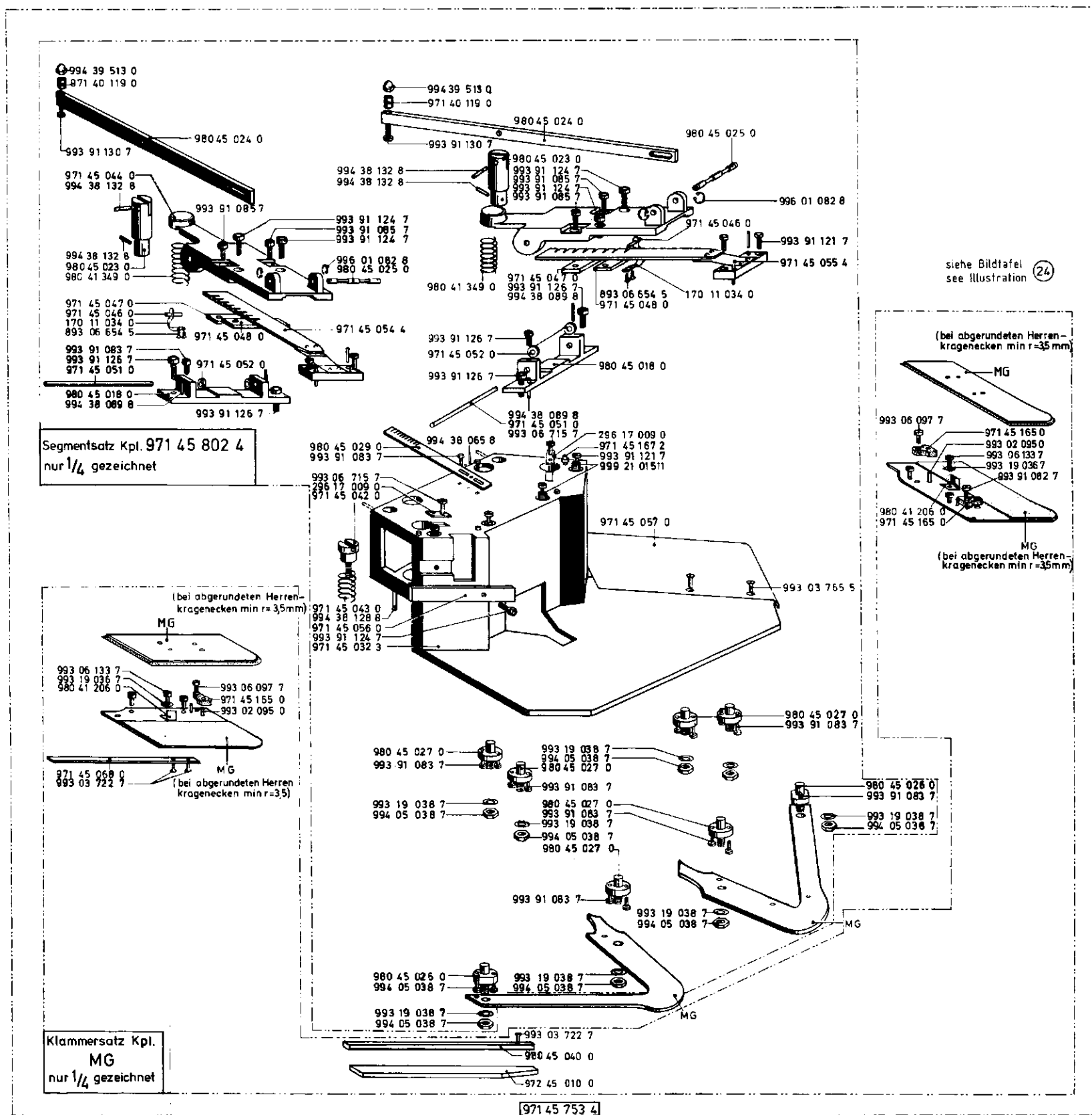
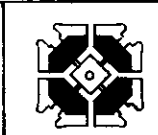

Segmentsatz Kpl. 971 45 802 4
nur 1/4 gezeichnet

Klammersatz Kpl. MG
nur 1/4 gezeichnet

siehe Bildtafel 24
see illustration 24

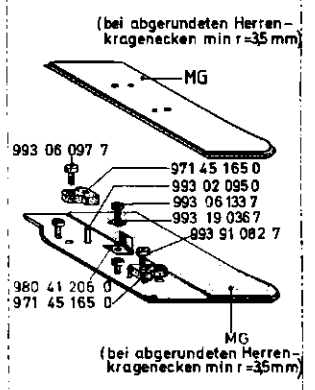



972 45 753 4 (Herrenkragen)

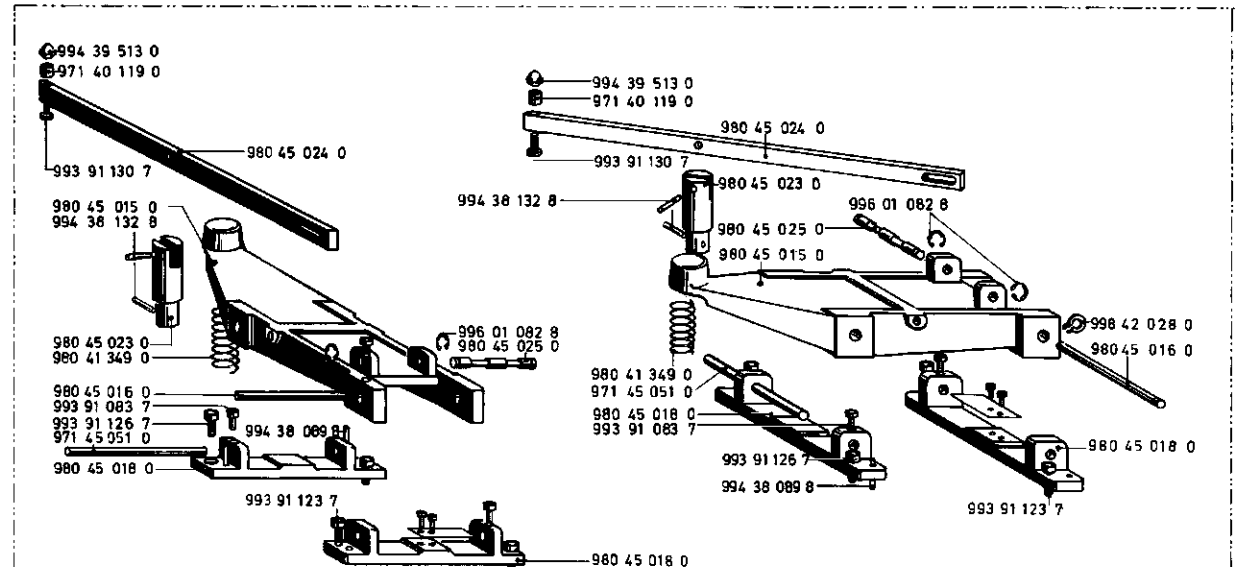

Segmentsatz Kpl. 971 45 804 4
nur 1/4 gezeichnet

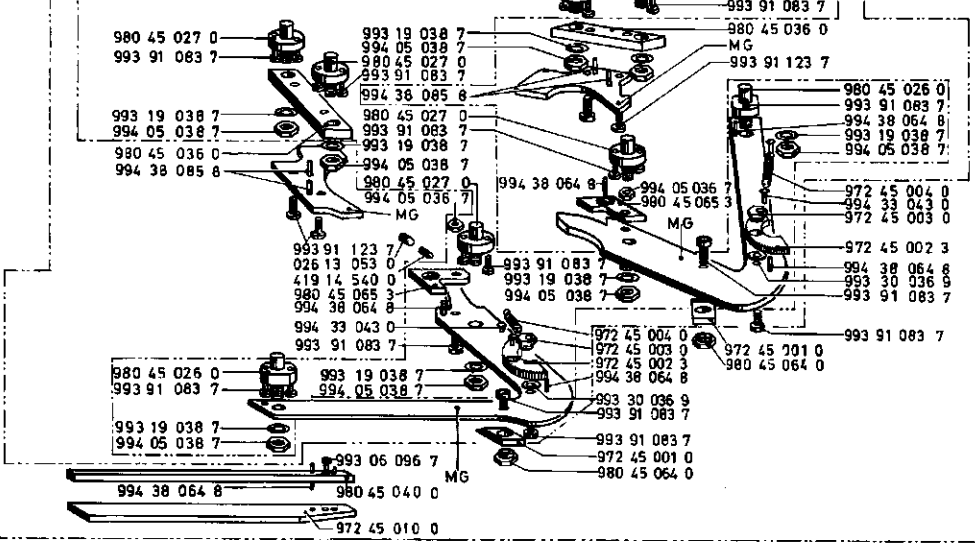
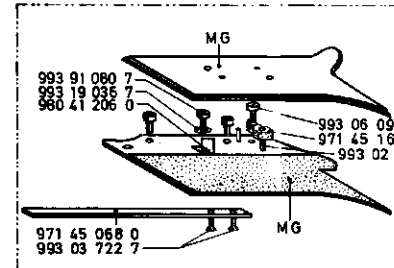
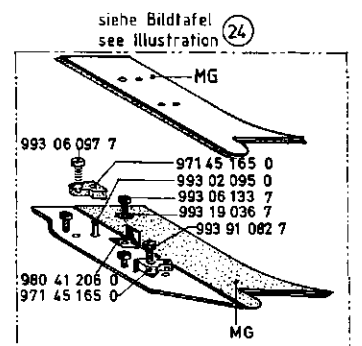
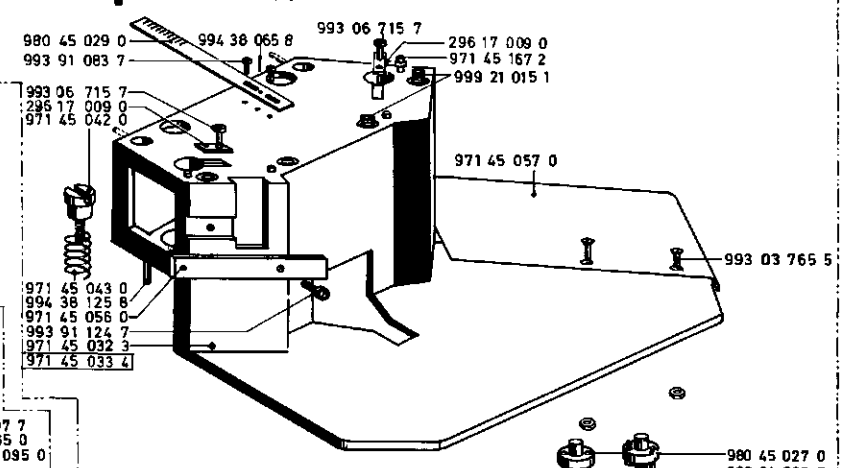

Klammersatz Kpl. MG
nur 1/4 gezeichnet

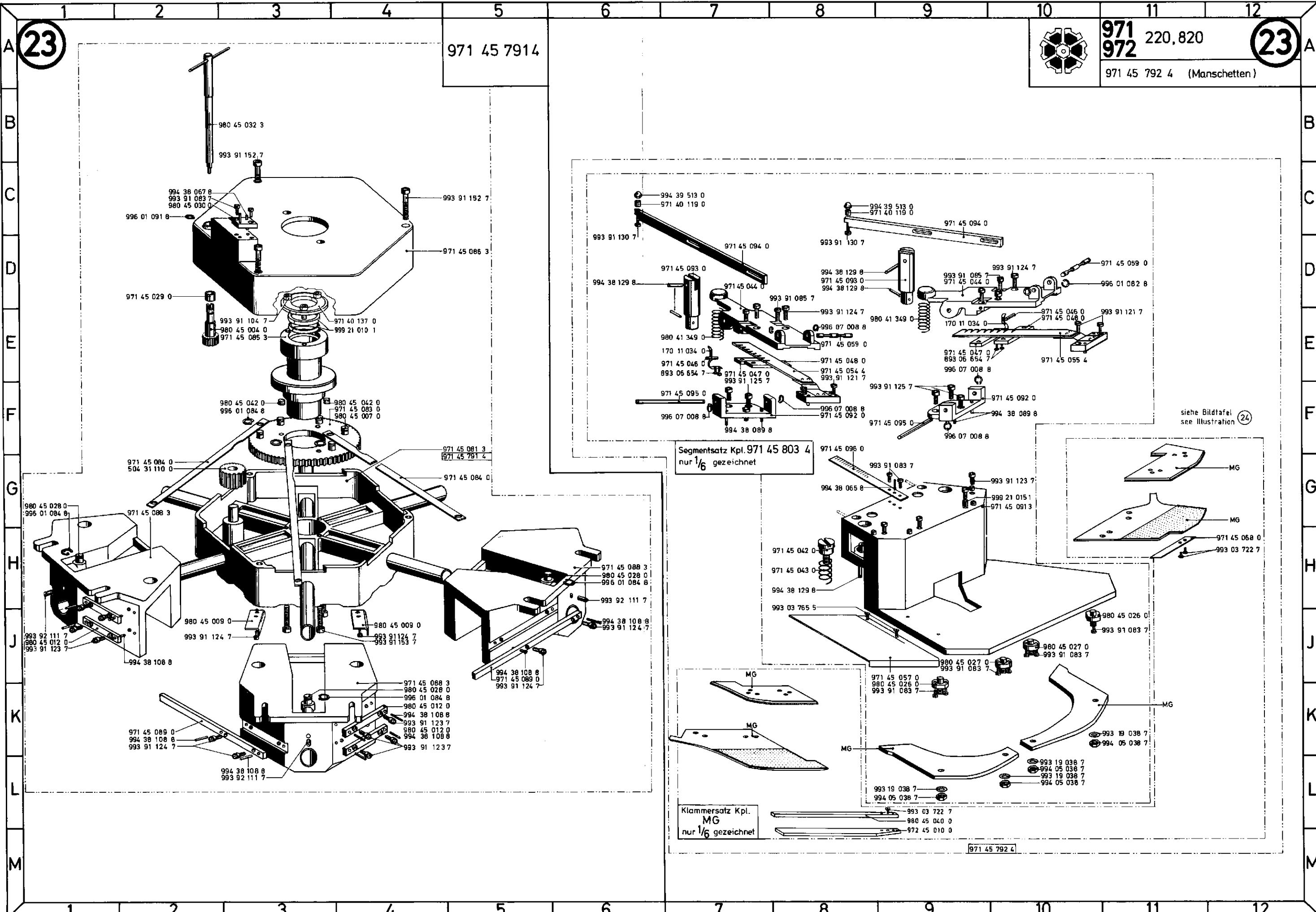

23

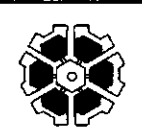

971 972 220,820
971 45 792 4 (Manschetten)

23

971 45 791 4

Segmentsatz Kpl. 971 45 803 4
nur 1/6 gezeichnet

siehe Bildtafel 24

Klammersatz Kpl. MG
nur 1/6 gezeichnet

971 45 792 4

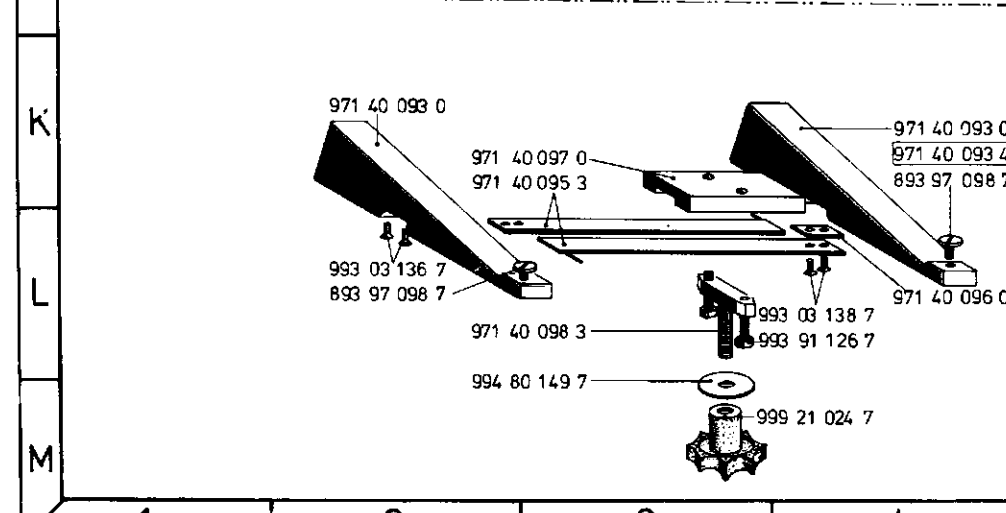
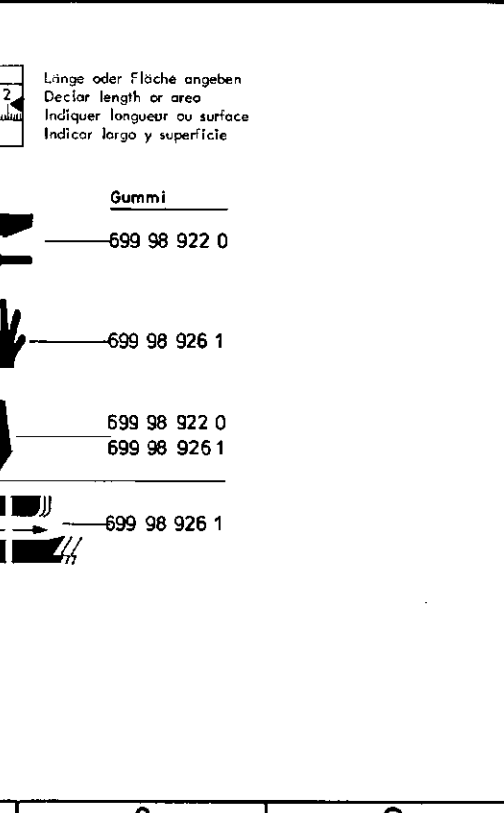
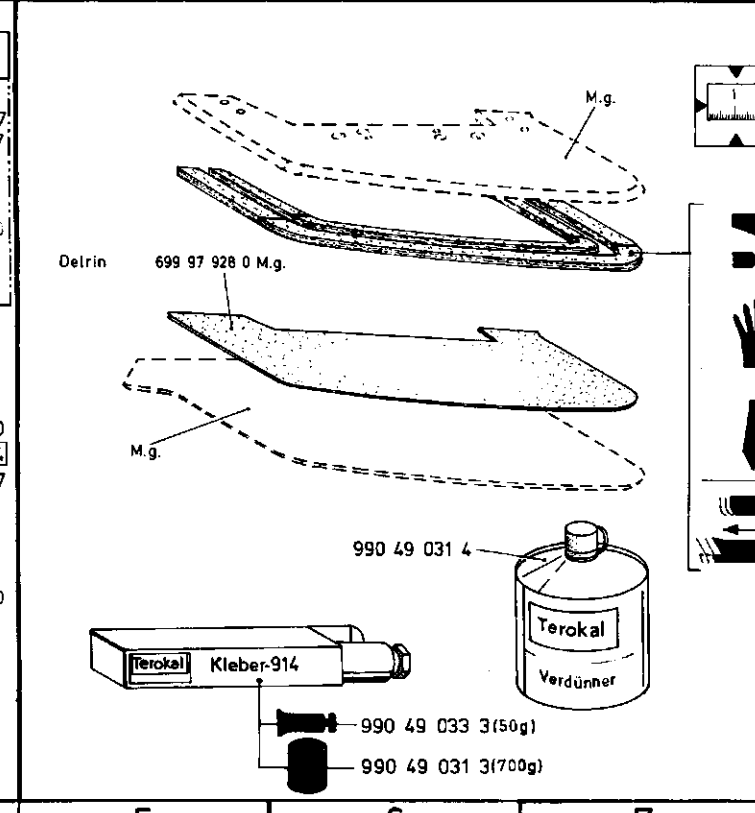
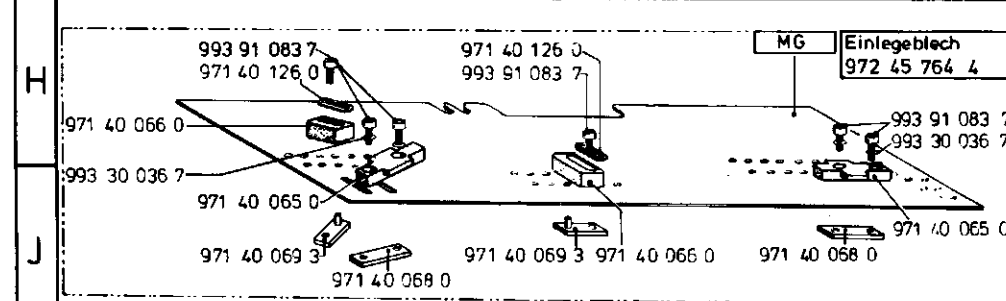
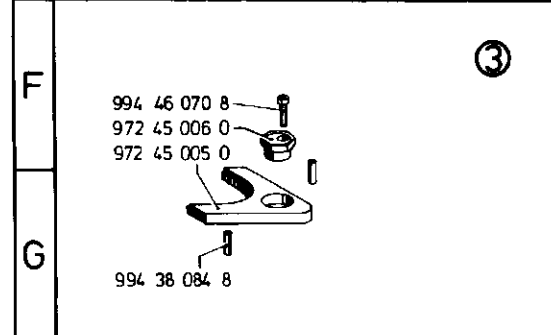
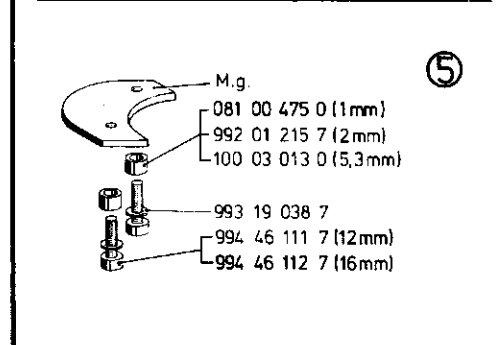
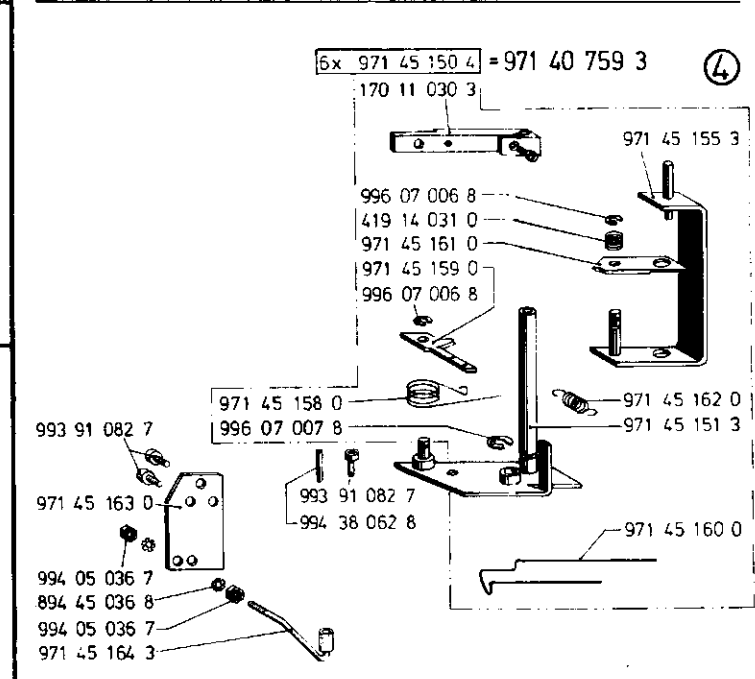
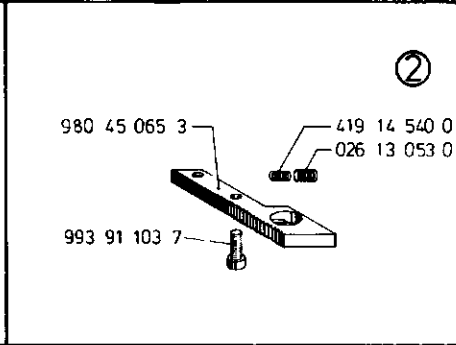
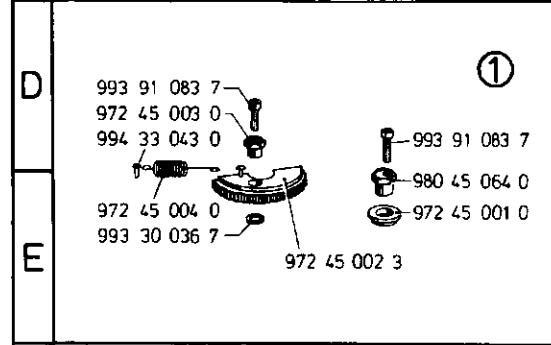
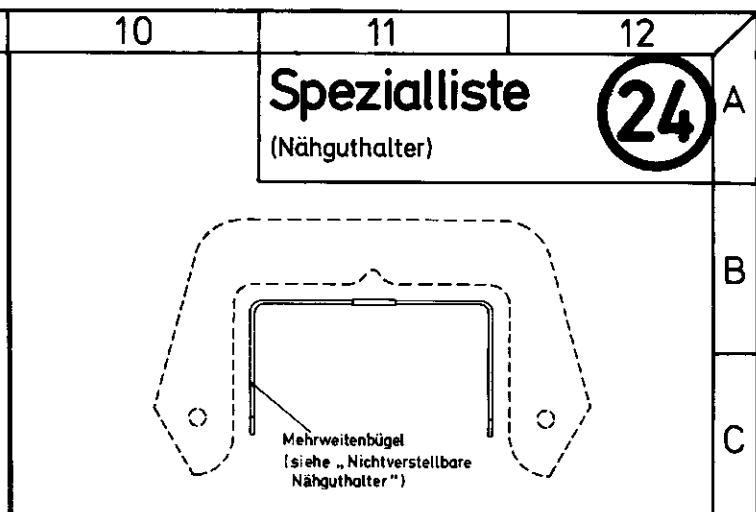
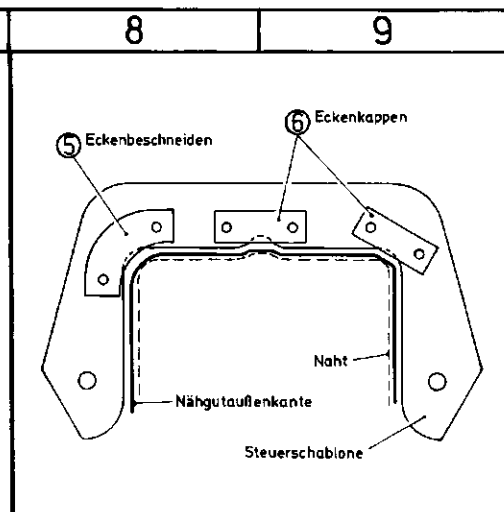
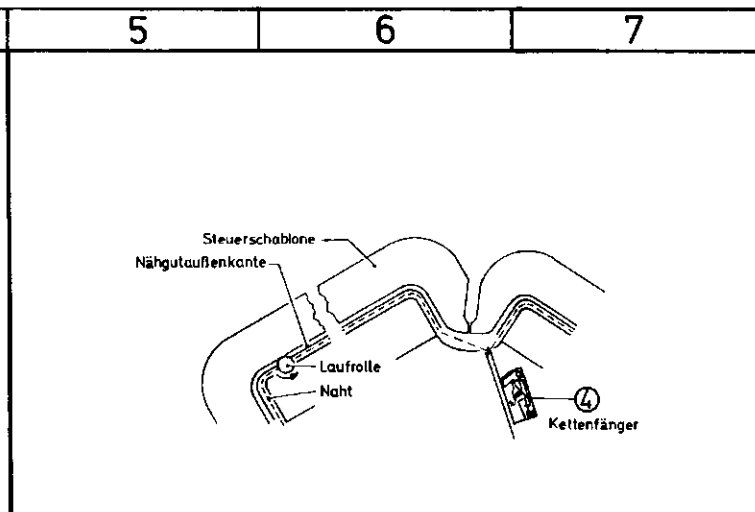
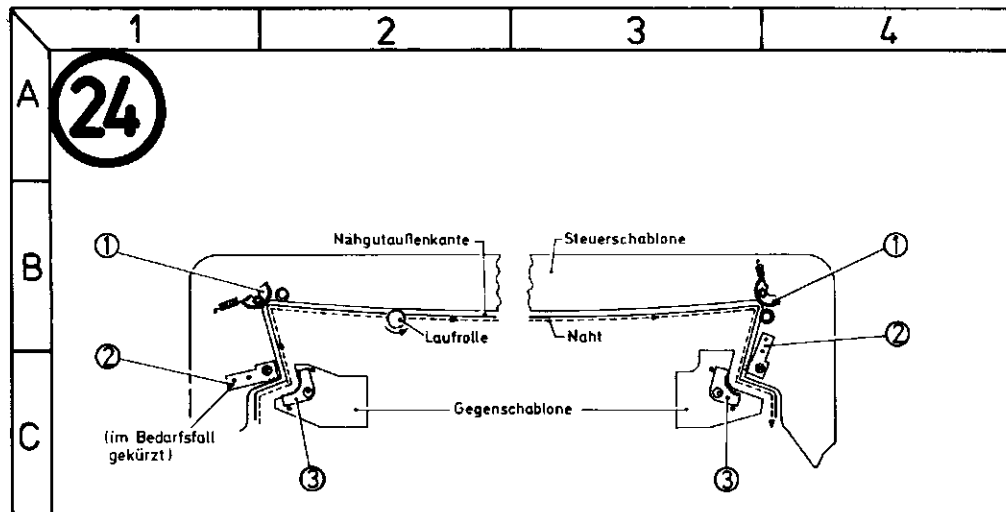

STapler	Länge	Breite	Stapeltiefe
ST 1/0 und ST1/1 Ablagefläche	300	165	170
ST 2/0 und ST2/1 Ablagefläche	500	165	155
ST 3/0 und ST3/1 Ablagefläche	300	240	170

971	ST-1/0(50Hz)
972	ST-1/1(60Hz)
971 42 751 4	(50Hz)
971 42 754 4	(60Hz)

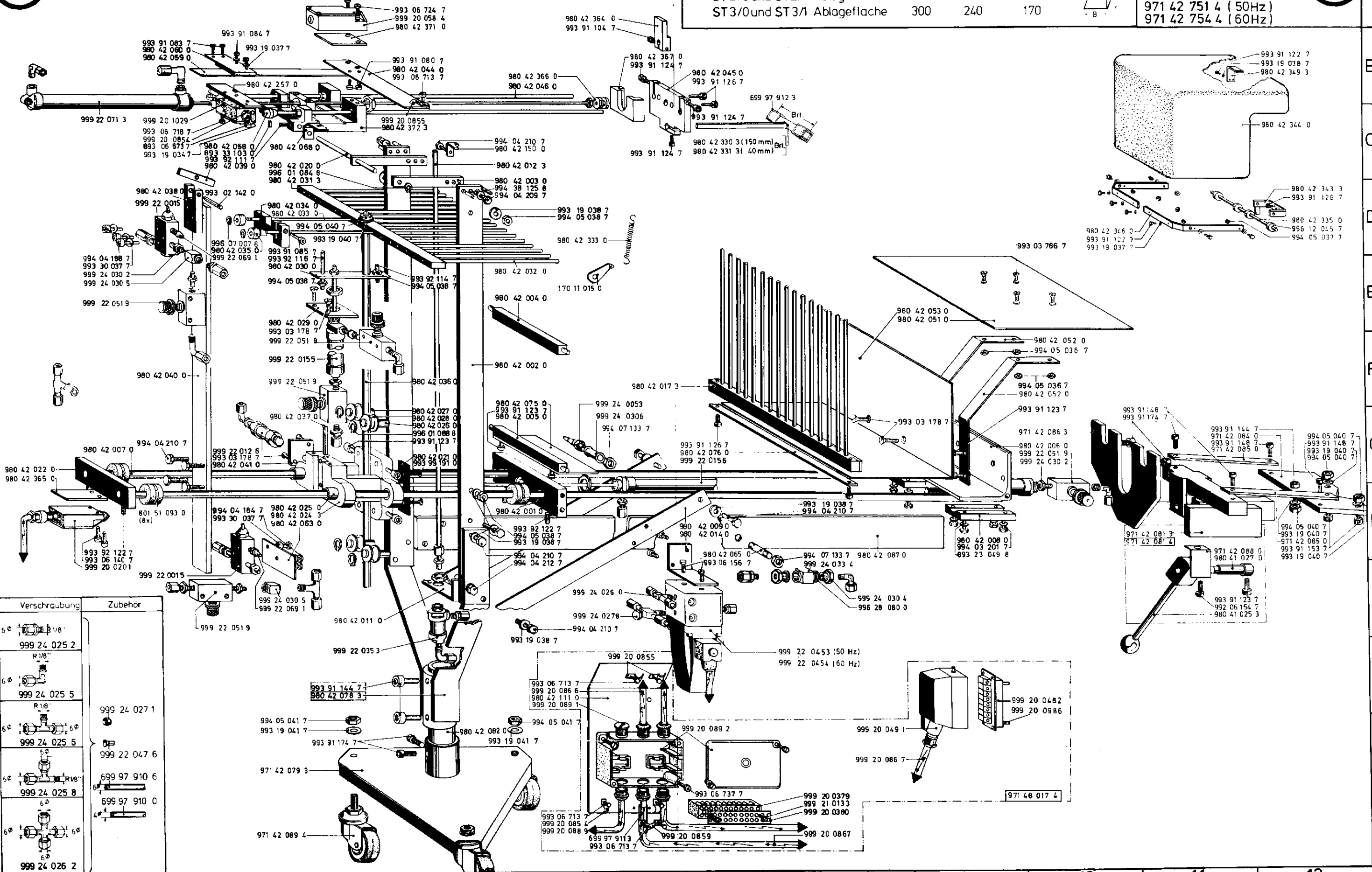

Verschraubung	Zubehör
5φ R 1/8"	999 24 025 2
6φ R 1/8"	999 24 025 5
6φ R 1/8"	999 24 027 1
6φ R 1/8"	999 24 025 5
6φ R 1/8"	999 24 027 1
6φ R 1/8"	999 24 025 5
6φ R 1/8"	999 24 027 1
6φ R 1/8"	999 24 025 5
6φ R 1/8"	999 24 027 1
6φ R 1/8"	999 24 025 5
6φ R 1/8"	999 24 027 1

STapler		Länge	Breite	Stapeltiefe
ST 1/0 und ST1/1	Ablagefläche	300	165	170
ST 2/0 und ST2/1	Ablagefläche	500	165	155
ST 3/0 und ST3/1	Ablagefläche	300	240	170

971	ST-2/0(50Hz)
972	ST-2/1(60Hz)
971 42 752 4 (50Hz)	
971 42 755 4 (60Hz)	

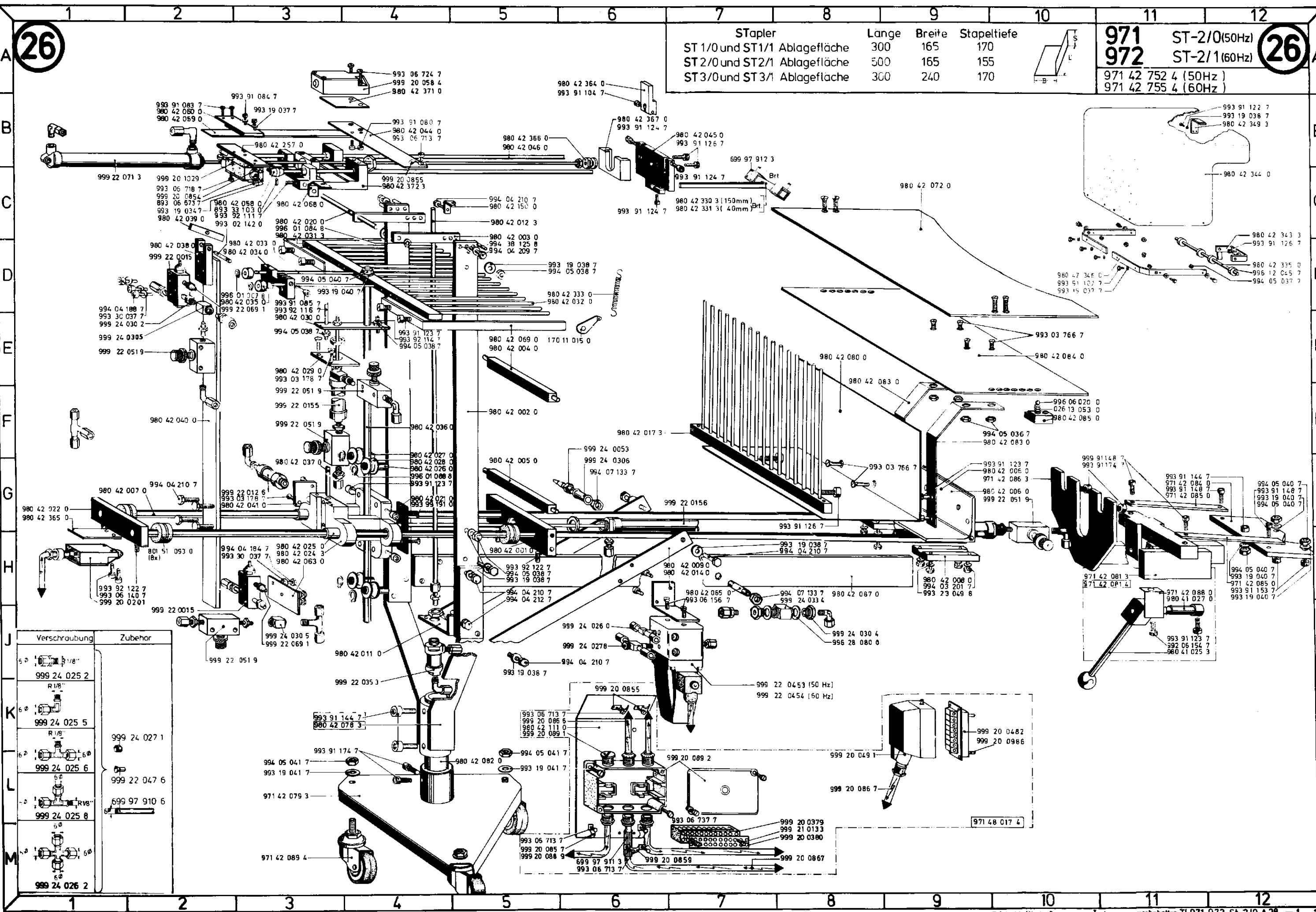

Verschraubung	Zubehör
5 \times R 1/8"	999 24 025 2
6 \times R 1/8"	999 24 025 5
6 \times R 1/8"	999 24 025 6
6 \times R 1/8"	999 24 025 8
6 \times R 1/8"	999 24 026 2

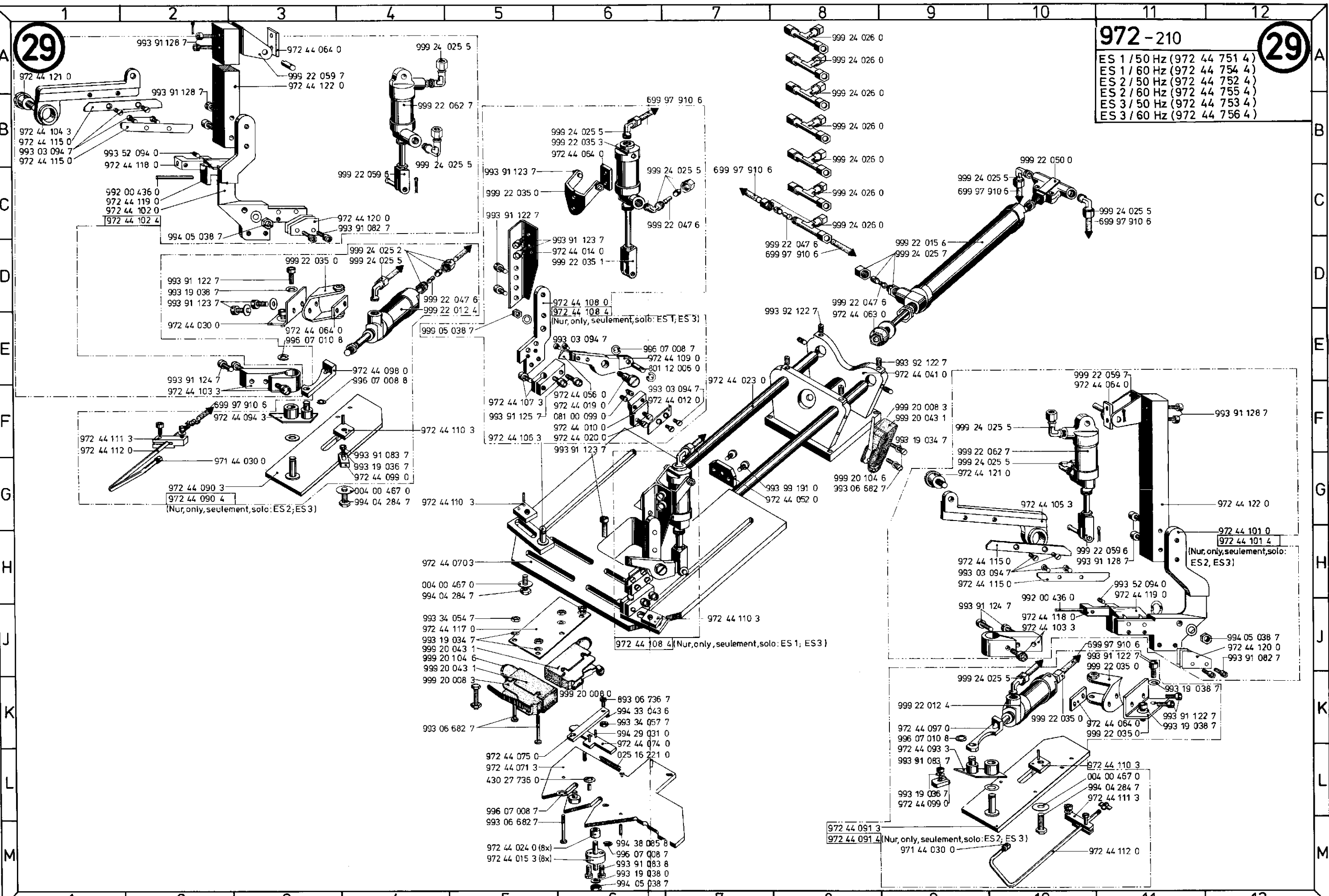

29

29

972-210
 ES 1 / 50 Hz (972 44 751 4)
 ES 1 / 60 Hz (972 44 754 4)
 ES 2 / 50 Hz (972 44 752 4)
 ES 2 / 60 Hz (972 44 755 4)
 ES 3 / 50 Hz (972 44 753 4)
 ES 3 / 60 Hz (972 44 756 4)

993 91 122 7
 993 19 038 7
 993 91 123 7
 972 44 030 0
 999 22 035 0
 999 24 025 5
 999 22 047 6
 999 22 012 4

972 44 108 0
 972 44 108 4
 (Nur, only, seulement, solo: ES 1, ES 3)
 993 03 094 7
 986 07 008 7
 972 44 109 0
 801 12 006 0
 972 44 056 0
 972 44 019 0
 993 03 094 7
 972 44 012 0
 972 44 107 3
 972 44 010 0
 972 44 020 0
 993 91 123 7
 993 91 125 7
 081 00 099 0
 972 44 010 0
 972 44 106 3
 972 44 020 0
 993 91 123 7

993 91 124 7
 972 44 103 3
 972 44 111 3
 972 44 112 0
 971 44 030 0
 993 91 083 7
 993 19 036 7
 972 44 099 0
 972 44 090 3
 972 44 090 4
 (Nur, only, seulement, solo: ES 2, ES 3)
 004 00 467 0
 994 04 284 7
 994 04 284 7
 993 34 054 7
 972 44 117 0
 993 19 034 7
 999 20 043 1
 999 20 104 6
 999 20 043 1
 999 20 008 3
 999 20 008 0
 893 06 736 7
 994 33 043 6
 993 34 057 7
 994 29 031 0
 972 44 074 0
 025 16 221 0
 972 44 075 0
 972 44 071 3
 430 27 736 0
 996 07 008 7
 993 06 682 7
 996 07 008 7
 993 06 682 7
 972 44 024 0 (8x)
 972 44 015 3 (8x)
 994 38 085 8
 996 07 008 7
 993 91 083 8
 993 19 038 0
 994 05 038 7

972 44 070 3
 004 00 467 0
 994 04 284 7
 993 34 054 7
 972 44 117 0
 993 19 034 7
 999 20 043 1
 999 20 104 6
 999 20 043 1
 999 20 008 3
 999 20 008 0
 893 06 736 7
 994 33 043 6
 993 34 057 7
 994 29 031 0
 972 44 074 0
 025 16 221 0
 972 44 075 0
 972 44 071 3
 430 27 736 0
 996 07 008 7
 993 06 682 7
 996 07 008 7
 993 06 682 7
 972 44 024 0 (8x)
 972 44 015 3 (8x)
 994 38 085 8
 996 07 008 7
 993 91 083 8
 993 19 038 0
 994 05 038 7

999 22 015 6
 999 24 025 7
 999 22 047 6
 972 44 063 0
 993 92 122 7
 999 22 047 6
 972 44 063 0
 993 92 122 7
 972 44 041 0
 999 20 008 3
 999 20 043 1
 999 24 025 5
 999 22 062 7
 999 24 025 5
 972 44 121 0
 972 44 105 3
 972 44 115 0
 993 03 094 7
 972 44 115 0
 993 91 124 7
 992 00 436 0
 972 44 118 0
 972 44 103 3
 993 91 124 7
 972 44 118 0
 972 44 103 3
 999 22 059 6
 993 91 128 7
 999 24 025 5
 999 22 035 0
 972 44 064 0
 993 19 038 7
 993 91 122 7
 999 22 035 0
 999 24 025 5
 999 22 012 4
 972 44 097 0
 996 07 010 8
 972 44 093 3
 993 91 083 7
 999 24 025 5
 999 22 035 0
 972 44 064 0
 999 22 035 0
 993 19 038 7
 993 91 122 7
 999 22 035 0
 993 19 038 7
 972 44 110 3
 004 00 467 0
 994 04 284 7
 972 44 111 3
 993 19 036 7
 972 44 099 0
 972 44 091 3
 972 44 091 4
 (Nur, only, seulement, solo: ES 2, ES 3)
 971 44 030 0
 972 44 112 0

Ersatzteilliste. Spare parts. Pièces de rechange. Piezas de repuesto.

Teile-Nr.	Benennung	Teile-Nr.	Benennung	Teile-Nr.	Benennung	Teile-Nr.	Benennung	Teile-Nr.	Benennung	Teile-Nr.	Benennung		
	KL.971/72	170 11 013 0	SPANNUNGSPLATTE 1F10	296 00 004 4	ARMWELLE 386	296 15 282 0	SPULE 2M1,1307,1302	396 10 027 3	GEGENGEWICHT 2C9	396 12 045 0	FADENOESE 1E2,2E2		
		170 11 013 4	SPANNUNGSPLATTE 1F10	296 00 005 1	HINT.LAGERGEH. 386	296 16 031 0	ZUGFEDER 1486	396 10 048 3	VERSCHLUSZSCHEIBE 1811, 2B11,3D8	396 12 046 3	NADELSTG.BUCHSE 1E4		
004 00 467 0	SCHLEIBE,ABSCHLUSS 2964, 29H5,29L11	170 11 014 0	BOLZEN 1F10	296 00 007 0	LAGEBGEH. 1C6,2C6,3D5	296 16 067 0	BUCHSE 1D8,1C8	396 10 049 0	SCHLEIBE 2C11,3D5	396 12 048 3	BUCHSE 2D3		
004 02 012 0	GLEITSCHONER 8L8	170 11 015 0	FADENF.PLATTE 1F10,25E6, 26E6,27E6	296 00 008 0	ANLAGERING 1C6,2C6 2C10	296 16 114 0	ZUGFEDER 17A3	396 10 051 0	FADENHEBELSCHUTZ 2E9	396 12 067 4	NADELSTANGE KPL. 1E4,2E3		
025 16 221 0	ZUGFEDER 29L6	170 11 020 0	DREHFEDER 168	296 00 009 0	SCHUTZGEHAEUSE 186,286, 386,3D8	296 17 009 0	BLATTFEDER 1867,1869, 19F9,19G7,20G7,20G9, 21F9,21G7,22F9,22G7	396 10 053 0	HALTEBLECH 2G4	396 15 281 4	GREIFER 212,2L5		
026 13 053 0	DRUCKFEDER 20K9,21K9, K9	170 11 021 0	ANSATZSCHN. 1H9	296 00 010 0	SCHUTZGEHAEUSE 1810,2C10	296 25 001 0	SCHUTZHAUBE 12E3,12L7, 13E3	396 10 055 4	LAGERGEHAEUSE 1C10,2C11, 3B8	396 17 008 0	DRUCKFEDER 2H2		
026 14 043 0	GUMMIFUSS 8M3	170 11 022 0	DISTANZSCHEIBE 168	296 00 012 0	SCHUTZGEHAEUSE 1810,2C10	296 31 080 0	KLOBEN 1D2,2C2	396 10 074 4	VERTEILER 1A7	396 17 011 3	AUSLÖSEHEBEL 2G1		
026 14 044 0	SCHLEIBE 8M3	170 11 023 3	FADENFUEHRUNG 1K6	296 00 014 0	KONUSHUELSE 2B11,3C8	296 31 085 0	BOLZEN 1D2,2D2	396 10 078 0	DRUCKFEDER 1D9	396 17 014 0	FEDER 2B2		
030 00 031 0	SCHLEIBE 1610,1L2	170 11 028 3	HALTER 1L4	296 00 018 0	FAD.REGULIERBUEGEL 2G7	296 31 086 0	ZUGSTANGE 2B7	396 10 088 0	FINGERSCHUTZ 2E5	396 17 015 4	SPULERVORSPANNUNG 2F7		
040 00 202 0	SCHLEIBE 8A1,8A5,8M6	170 11 030 3	STELLKLEMM 1K4,24D6	296 00 033 0	OELDOCHT 2B3	296 31 086 3	ZUGSTANGE 1B8	396 10 091 3	VENTILGEHAEUSE 1B6,2B6, 3B5	396 17 016 3	FADENFUEHRUNG 2E7		
053 00 035 0	SCHLEIBE 1F11,269	170 11 031 0	STELLWINKEL 1K5	296 00 034 0	LENKERBOLZEN 2B3	296 31 086 0	ZUGSTANGE 1B8	396 10 091 3	VENTILGEHAEUSE 1B6,2B6, 3B5	396 17 022 0	BUNDBUCHSE 1B8,2B7		
067 00 930 0	DRUCKFEDER 14G11	170 11 032 0	DREHFEDER 1L4	296 00 035 3	STELLRING 2B4	296 31 095 0	OELDOCHT 1B6,2B9,413,417, 4J11	396 10 094 0	REGULIERSCHR. 1B5,2A6,3B5	396 17 024 3	SPULERRAD 2H1		
067 11 011 0	FUEHRUNGSROLLE 4L2	170 11 033 0	VERSCHLUSSKLOTZ 1M5	296 00 040 0	NADELSTG.FUEHRUNG 296 00 041 0	GLEITSTEIN 1D4,2D4,3D4	296 31 096 0	OELSCHLAUCH 1D8,2D9,2E8	396 10 094 0	REGULIERSCHR. 1B5,2A6,3B5	396 17 025 3	SPULERBOCK 2H2	
067 24 005 0	ACHSE 14L7	170 11 034 0	BLATTFEDER 1M5,18E6,18E10, 19F6,19E6,20E6,20E10, 21E6,21E10,23E7,23E9	296 00 041 0	GLEITSTEIN 1D4,2D4,3D4	296 00 048 0	ANLAUFSCHLEIBE 2C4	296 31 097 0	OELSCHLAUCH 1A8	396 10 094 0	REGULIERSCHR. 1B5,2A6,3B5	396 17 026 0	EINRUECKKLOBEN 2H2
067 32 015 0	DRUCKFEDER 2M2	170 11 035 0	RASTBOLZEN 1M5	296 00 048 0	ANLAUFSCHLEIBE 2C4	296 00 049 3	GEGENGEWICHT 1C9,3C6	296 31 098 0	STOPPEN 1D6	396 10 094 0	REGULIERSCHR. 1B5,2A6,3B5	396 17 028 3	AUSLÖSENOCKEN 2G1
068 00 306 0	BUCHSE 17C16	170 11 036 0	FADENGABEL 1M6	296 00 049 3	GEGENGEWICHT 1C9,3C6	296 00 050 0	DOCHT 1C2,2C2,3D2	296 33 003 3	HUBEXZENTER 1C7,2C7	396 11 002 0	FADENFUEHR.STIFT 1D8,2D7	396 17 033 3	SPULERWELLE 2G2
068 00 533 0	FADENF.SCHLEIBE 266	170 11 038 0	SPANNUNGSFEDER 1G4,1H2, 1F2	170 12 004 3	NADELSTG.KLOBEN 1D3	296 00 051 0	SCHLEIBE 2A3	296 33 003 4	HUBEXZENTER 1C7,2C7	396 11 019 4	GARNSTAEWDER 11K4	396 17 033 3	SPULERWELLE 2G2
068 00 535 0	FADENF.BOLZEN 266	170 15 002 3	ZAHNRIEMENRAD 1L3	170 15 002 3	ZAHNRIEMENRAD 1L3	296 00 051 0	SCHLEIBE 2A3	296 35 029 0	BUCHSE 1C1,2C1	396 11 026 0	SPANNUNGSHUELSE 2F7	396 17 033 3	SPULERWELLE 2G2
068 00 626 0	SCHLEIBE 14E8	170 15 004 0	NELLE 1L6	170 15 004 0	NELLE 1L6	296 00 056 3	VENTILGEH. 1A9	370 10 020 3	ROHR 1A9	396 11 031 0	BUCHSE 2F7	396 17 033 3	SPULERWELLE 2G2
068 11 103 0	FADENSP.DRUCKFEDER 2B5	170 15 005 0	LAGERBUCHSE 1K6	170 15 005 0	LAGERBUCHSE 1K6	296 00 068 0	DICHTSCHEIBE 296 00 069 0	370 11 001 0	FADENFUEHRUNG 1E9	396 11 032 0	FADENOESE 2D3	396 17 033 3	SPULERWELLE 2G2
068 33 023 0	DRUCKFEDER 4J3,4J7,4J11	170 15 006 0	SCHLEIBE 1L6	170 15 006 0	SCHLEIBE 1L6	296 00 069 0	OELFILZ 296 00 071 0	370 11 006 0	REGULIERBUEGEL 1E7	396 11 033 0	FADENFUEHRUNG 2G6	396 17 033 3	SPULERWELLE 2G2
069 00 254 0	DRUCKFEDER 17M15	170 15 007 3	FADENGEWEBER 1L4	170 15 007 3	FADENGEWEBER 1L4	296 00 071 0	OELSCHLAUCH 1E9,1B8,1L7, 2E8,3E8	370 11 007 0	KLEMMSCHEIBE 1E7	396 11 034 0	FADENBLECH 2F4	396 17 033 3	SPULERWELLE 2G2
077 11 022 0	AUFLAGE 11J3	170 15 008 0	SPANNUNGSFEDER 1G4,1H2, 1F2	170 15 008 0	SPANNUNGSFEDER 1G4,1H2, 1F2	296 00 101 0	OELDOCHT 1C5,2C5,3D4	370 11 010 4	FADENFUEHRUNG 1K6	396 11 040 4	ROLLENSPANNUNG 2E7,2J2	396 17 033 3	SPULERWELLE 2G2
077 11 023 0	ZENTRIERSTUECK 11J4, 12F11	170 15 009 0	DICHTUNG 1H2	170 15 009 0	DICHTUNG 1H2	296 00 112 0	OELDOCHT 1B11,2E10,3E9	370 11 011 0	DREHFEDER 1K4	396 11 041 3	SPANNUNGSBOLZEN 2J1	396 17 033 3	SPULERWELLE 2G2
077 11 025 0	ABSCHL.STUECK 11G4	170 15 010 0	ZAHNFORMRIEMEN 1M6	170 15 010 0	ZAHNFORMRIEMEN 1M6	296 00 112 0	OELDOCHT 1B11,2E10,3E9	370 11 012 0	LEITBLECH 1H8	396 11 042 0	BUCHSE 2K1	396 17 033 3	SPULERWELLE 2G2
081 00 023 0	MUTTER 3E2,13F11	170 15 012 4	SCHWINGE 1K3	170 15 012 4	SCHWINGE 1K3	296 00 114 0	DROSSELRING 2E9,3E9	370 12 001 0	NADELSTG.FUEHRG. 1D5	396 11 043 3	ZAHNSCHLEIBE 2K1	396 17 033 3	SPULERWELLE 2G2
081 00 099 0	DRUCKFEDER 29F6	170 15 013 0	GER.DECKEL 1H1	170 15 013 0	GER.DECKEL 1H1	296 00 118 0	HUELSCHN. 1D10	370 12 002 0	BLASDRHR 1D2	396 11 044 0	SCHLEIBE 2J1	396 17 033 3	SPULERWELLE 2G2
081 00 118 0	SPANN.SCHLEIBE 1F7	170 15 014 0	LAGERBUCHSE 1K6	170 15 014 0	LAGERBUCHSE 1K6	296 00 120 0	SCHLEIBE KUPFER 1E10	370 12 005 4	ARMWELLENKURBEL 1C4	396 11 045 3	AUSLÖSESCHEIBE 2J2	396 17 033 3	SPULERWELLE 2G2
081 00 475 0	SCHLEIBE 14J9,24D9,24G8	170 15 015 0	GER.DECKEL 1H1	170 15 015 0	GER.DECKEL 1H1	296 00 121 0	OELSCHLAUCH 1D10	370 15 001 0	SCHLEIBE 1K6,1K7	396 11 046 0	DRUCKFEDER 2K2	396 17 033 3	SPULERWELLE 2G2
081 00 232 0	KLEMMSTUECKHUELSE 2G5	170 15 016 0	DICHTUNG 1H2	170 15 016 0	DICHTUNG 1H2	296 00 125 0	DICHTSCHEIBE 1B10	370 15 013 4	LAGERBUCHSE 1K6	396 11 047 0	DRUCKFEDER 2F7	396 17 033 3	SPULERWELLE 2G2
081 00 296 0	ZUGFEDER 17F3	170 15 017 0	WELLE 1K3	170 15 017 0	WELLE 1K3	296 00 131 3	OELINFUELLSCHR. 1A10	370 15 020 3	KURBELW.LAGER 1J4	396 11 048 0	BUCHSE 2K1	396 17 033 3	SPULERWELLE 2G2
088 00 488 0	ZUGFEDER 1L1	170 15 018 0	ZAHNFORMRIEMEN 1M6	170 15 018 0	ZAHNFORMRIEMEN 1M6	296 00 136 0	HIN.OELROHR 1B10	370 15 023 3	GURTRAD 1L6,1J5	396 11 049 0	DRUCKFEDER 2F7	396 17 033 3	SPULERWELLE 2G2
088 15 735 0	ZUGFEDER 17F4	170 15 019 0	SCHWINGE 1K3	170 15 019 0	SCHWINGE 1K3	296 00 140 2	OELDOCHT 296 00 144 0	370 15 038 0	GREIFER 1K6	396 11 050 0	FADENLEITARM 11H4	396 17 033 3	SPULERWELLE 2G2
091 00 213 0	ZAHNFORMRIEMEN 1L10,2D10, 2L10	171 15 017 0	WELLE 1K3	171 15 017 0	WELLE 1K3	296 00 144 0	SCHLAUCHNIPP 1B10,1L3, 2N7,4D3	371 15 001 0	SPREIZER 1K7,12D1,12D7	396 11 101 3	TRAEGER 11K4	396 17 033 3	SPULERWELLE 2G2
095 00 402 0	FADENF.OESE 1E3	171 15 029 0	DICHTUNG 1H2	171 15 029 0	DICHTUNG 1H2	296 00 208 3	SPANNROLLENLAGER 1F11, 2G10	371 15 005 0	SPREIZENTRAEGER 1K7	396 11 102 3	FADENLEITARM 11H4	396 17 033 3	SPULERWELLE 2G2
096 14 195 3	STELLRING 1L9	196 00 002 3	KOPFDECKEL 1E5,3E4	196 00 002 3	KOPFDECKEL 1E5,3E4	296 00 209 0	SPANNROLLEN ACHSE 1G11, 2G9	371 15 006 3	KLOBEN 1K6	396 11 103 0	FADENOESE 11H3	396 17 033 3	SPULERWELLE 2G2
097 00 335 0	LI.ZYL.SCHNR. 1B5,2A4,3B3	196 00 006 0	HANDRAD 1011,2D11,4L8	196 00 006 0	HANDRAD 1011,2D11,4L8	296 00 209 0	SPANNROLLEN ACHSE 1G11, 2G9	371 15 007 0	GER.DECKEL 1J7	396 11 104 0	GARNROLLENTELLER 11K3	396 17 033 3	SPULERWELLE 2G2
099 00 494 0	FEDER 2D6	196 00 019 0	VERSCHL.SCHR.B. 1C4,2C3	196 00 019 0	VERSCHL.SCHR.B. 1C4,2C3	296 00 209 0	SPANNROLLEN ACHSE 1G11, 2G9	371 15 008 0	WINKEL 9D4	396 11 105 0	GARNR.STIFT 11J4	396 17 033 3	SPULERWELLE 2G2
100 03 012 3	KLOBEN 4F10	196 00 022 0	FADENFUEHRUNG 1F7	196 00 022 0	FADENFUEHRUNG 1F7	296 00 209 0	SPANNROLLEN ACHSE 1G11, 2G9	371 15 010 4	KURBELWELLENLAGER 1J5	396 11 106 3	GARNST.ROHR 11L4	396 17 033 3	SPULERWELLE 2G2
100 03 013 0	DISTANZSCH. 24D9,24F8	196 00 029 0	STELLBUCHSE 2J1	196 00 029 0	STELLBUCHSE 2J1	296 00 210 4	SPANNROLLE 1F11,2F10	371 15 011 4	ZUGSTANGE 1J4	396 11 107 0	GARNST.ROHR 11J4	396 17 033 3	SPULERWELLE 2G2
104 11 102 0	FADENSP.FEDER 1G10	196 00 042 4	NADELSTG.KLOBEN 1D3	196 00 042 4	NADELSTG.KLOBEN 1D3	296 00 210 4	SPANNROLLE 1F11,2F10	371 15 015 3	KLEMMBOLZEN 1L2	396 12 007 3	ARMWELLENKURBEL 1B3,2C5	396 17 033 3	SPULERWELLE 2G2
170 11 001 0	SPANNUNGSBLECH 1F6	196 00 043 3	NADELSTG.GELENK 2C4,3C4	196 00 043 3	NADELSTG.GELENK 2C4,3C4	296 00 211 3	ZAHNRIEMENRAD 1L10	371 15 016 4	GELENKNELLE 1L3	396 12 008 3	FADENHEBEL 2A4	396 17 033 3	SPULERWELLE 2G2
170 11 001 4	SPANNUNGSBLECH 166	196 00 044 0	BUCHSE 1C4,2C3,3D2	196 00 044 0	BUCHSE 1C4,2C3,3D2	296 00 212 3	ZAHNRIEMENRAD 1C10,2C9	371 15 017 0	BUCHSE 1G1	396 12 010 4	ARMWELLENKURBEL 2D5	396 17 033 3	SPULERWELLE 2G2
170 11 002 0	FUEHRG.DRAHT 1G6	196 00 047 0	FEDER 1C2,2C2,3D2	196 00 047 0	FEDER 1C2,2C2,3D2	296 10 003 4	ARMWELLE 1C8,2C8	371 15 020 0	BUCHSE 161	396 12 011 0	STIRNRAD 2362	396 17 033 3	SPULERWELLE 2G2
170 11 004 0	FADENGEWEBER 1D4	196 00 048 0	OELDOCHTWINKEL 304	196 00 048 0	OELDOCHTWINKEL 304	296 10 003 0	ARMWELLE 108,2C9	371 15 028 4	DOPPELEXZENTER 1J4	396 12 012 0	STIRNRAD 2362	396 17 033 3	SPULERWELLE 2G2
170 11 006 0	SCHUTZBUEGEL 1E6	196 00 049 0	NADELLAGER 1C4,2C4,3C3	196 00 049 0	NADELLAGER 1C4,2C4,3C3	296 10 011 3	BEF.SCHR. 1B8,2B9,3B6	371 15 031 4	GREIFERGEHAEUSE 1H5,1E4	396 12 013 0	VENTILSCHRAUBE 1B3,2B3	396 17 033 3	SPULERWELLE 2G2
170 11 007 0	FUEHRUNGSBLECH 1F7	196 00 051 0	DICHTUNG 1D5,3E4	196 00 051 0	DICHTUNG 1D5,3E4	296 10 012 0	ARMWELLENST. 1C9,2C9,3B7	381 10 041 0	OELSTANDSAUGE 1J7	396 12 014 0	FUEHRUNG 2D4,3D4	396 17 033 3	SPULERWELLE 2G2
170 11 008 0	TRAGSCHRAUBE 1E9	196 00 052 0	VERSCHL.STOPFEN 1B4,1D6	196 00 052 0	VERSCHL.STOPFEN 1B4,1D6	296 10 017 0	ARMDECKEL 261	381 10 042 0	DICHTUNGSRING 1J7	396 12 015 0	SCHRAUBE 1B2,2C2	396 17 033 3	SPULERWELLE 2G2
		196 00 053 0	STIRNRAD 2M9	196 00 053 0	STIRNRAD 2M9	296 10 017 4	ARMDECKEL 2G1,2D9	381 10 043 0	OELBLASS SCHR. 1K7	396 12 016 0	SPANNUNGSBLECH 2A4,3D4	396 17 033 3	SPULERWELLE 2G2
		296 00 003 0	ARMDECKEL 1C8,1D8,3D8	296 13 011 0	STOPFDR.FUEHRUNG 1E2,2D2	296 10 011 0	STOPFDR.FUEHRUNG 1E2,2D2	381 11 002 0	FADENF.PLATTE 1F10	396 12 017 0	BUCHSE 1D2,2		

Ersatzteilliste. Spare parts. Pièces de rechange. Piezas de repuesto.

Teile-Nr.	Benennung	Teile-Nr.	Benennung	Teile-Nr.	Benennung	Teile-Nr.	Benennung	Teile-Nr.	Benennung	Teile-Nr.	Benennung	
699 97 928 0	PL0 5x1100x1000	2435		382		970 43 008 3	KEILRIEMENSCH.	5F7		971 40 002 3	STUETZSAEULE	8D10,1508
699 97 941 6	SCHL.1 LxWxH,5	2L6,2M7		137		970 43 009 3	KEILRIEMENSCH.	5D10		971 40 003 0	ZENTRIERSCHRAUBE	8G9,8610
699 98 922	OGUMMI	2438,24K8,24L8				970 43 011 3	LAUFROLLE	5B8,6M9		971 40 004 0	ZENTRIERSTUECK	8G9
699 98 926 1	PL 3,0x1000x1000	24K8,24L8				970 43 012 0	LAUFROLLE	6J9		971 40 005 0	DISTANZHUELSE	8C9,8C10
699 99 158 0	DELDOUCHT.RU.1,5	4F3,4F7,4F11				970 43 013 0	KAEFIG	5C3,5D7		971 40 006 0	LAGERBOLZEN	9L6
801 11 017 0	SPANNSCHR.	2K2				970 43 014 0	DECKEL	5D3,5E7		971 40 007 3	LAGERHUELSE	9L6
801 11 018 0	SCHIEBE	2K2				970 43 016 0	SCHIEBE	5D1,5E8		971 40 008 0	SCHALTFAHNE	9L6
801 11 020 3	SPANNUNGSKNOPF	2J2				970 43 018 0	ZAHNROLLE	5A8,6F9,6G9		971 40 010 4	SCHALTRING	9L6
801 11 021 0	FADEMANZUGSFEDER	2J1				970 43 019 0	LAUFROLLE	5A8,6G9		971 40 011 0	DREHFEDER	9K6
801 12 006 0	GELENKBOLZEN	2B38,29E7				970 44 001 0	LAUFROLLE	6J9		971 40 012 0	HALTER	11C10
801 40 063 0	DISTANZBUCHSE	17F17,17H6,17I16				970 44 002 0	LAUFROLLE	6J9		971 40 013 0	STEBHALTER	8J12
801 40 083 3	ABDECKPLATTE	8G1				971 01 001 3	TISCHPLATTE	8B6,15H8,15H11		971 40 014 0	KABELHALTER	11J11
801 48 037 4	SCHUTZHAUBE	9L9,9K11				971 01 002 3	TISCHPLATTE	15H2,15H5		971 40 018 3	RUNDPLATTE	8M3
801 51 093 0	DAEMPFRING	25H2,26H2,27H2				971 01 003 3	TISCHPLATTE	15H2		971 40 020 0	RASTERBLECH	8L5,9K2
802 41 559 0	BOLZEN	14G11,14K11				971 01 004 3	TISCHPLATTE	15H8,15H11		971 40 021 0	WINKEL	9J3
802 51 199 0	GABELKOPF	17E2				971 01 006 0	TISCHPLATTE	14C4		971 40 023 0	ANSTANDSSCHIEBE	8K5,8L5
893 02 143 0	ZYL.STIFT	181				971 10 001 0	OBERRAMM	1610		971 40 024 0	DRUCKFEDER	8L5
893 03 041 0	SENKNSCHR.	4E3,4E7,4E11,4F3,4F7,4F11,12G10,13G10				971 10 001 4	OBERTHEIL KPL.	1810		971 40 025 3	FUSSSTRIIT	8K7
893 03 722 6	SENKNSCHR.	1G7				971 10 003 0	OELESTIEGROHR	1810		971 40 026 0	SCHWENKBOLZEN	8H10
893 03 725 6	SENKNSCHR.	1G7,14C8,14E8				971 10 004 0	OELETSCHLAUCH	109		971 40 027 0	SPANNHEBEL	8H10
893 03 765 6	SENKNSCHR.	1G7,3J3				971 10 005 4	OELEINFUELLNSCHR.	1A10		971 40 028 0	RIEMENSPELLER	8H12
893 03 766 7	SENKNSCHR.	4G3,4G7,4G11				971 10 006 0	HOHLSCHN.	1E10		971 40 029 0	ANSCHLAGBOLZEN	8G9
893 06 654 7	ZYL.SCHR.	11G,19E6,19E9,20E6,20E9,21E6,21E9,23E7,23E9				971 10 008 0	SCHLAUCHWIPPEL	109		971 40 030 0	STUETZBOLZEN	8F2,8F7
893 06 672 6	ZYL.SCHR.M3X4	1F7				971 10 014 3	DELFALLROHR	1010		971 40 031 0	AUFLAGEPLATTE	8F2
893 06 673 7	ZYL.SCHR.M3X5	17M13,25C2,26C2,27C2				971 11 001 4	WEYSSCHLUSSKLOTZ	1M5		971 40 034 3	TAEGER	8D4
893 06 674 7	ZYL.SCHR.M3X6	1G4,1F1,1M1,2F4				971 11 003 0	WINKEL	1K5		971 40 037 3	TAEGER	8F6
893 06 675 7	ZYL.SCHR.M3X8	1L8,1H1				971 14 001 0	UNTERARM	1M10		971 40 039 0	ANSCHLAG	8D4,8D6
893 06 714 7	ZYL.SCHR.M4X6	9J3				971 14 002 3	ABDECKPLATTE	1G5		971 40 041 0	STECKERHALTER	9E5
893 06 715 7	ZYL.SCHR.M4X8	1H4				971 14 003 3	SCHUTZKAPPE	1L9		971 40 042 0	ANSCHRAUBPLATTE	9J6,28L5
893 06 734 6	ZYL.SCHR.M5X6	1F9				971 14 005 2	HALTER	1K7		971 40 044 0	AUSLUESEROHR	8M10,15G2,15G8,15H6
893 06 736 7	ZYL.SCHR.M5X10	11M10,28J4,29K6				971 14 008 3	VERSCHLUSSPLATTE	1G7		971 40 045 0	HALTERSCHIEBE	16C3
893 06 738 7	ZYL.SCHR.M5X16	9E5				971 14 010 0	DICHTUNG	1M7		971 40 046 3	ABDECKBLECH	8H7
893 08 556 0	HALBRD.SCHR.M3X10	1J2				971 14 012 0	PLATTE	1L8		971 40 047 3	ABDECKBLECH	8M5
893 21 107 8	FEDERSCHIEBE	9C2				971 14 013 0	LAGEBOLZEN	1K8		971 40 055 0	ANTRIEBSWELLE	8J10
893 23 047 8	FEDERSCHIEBE	1D7,2E7				971 14 022 0	ABDECKBLECH	1G7		971 40 057 0	MOTORWIPPE	8H10
893 23 048 8	FEDERSCHIEBE	2K2				971 14 023 0	EINLAUFBLECH	1K8		971 40 058 0	MANSCHEITTE	9C10
893 23 048 8	FEDERSCHIEBE	25H9,26H9,27H9				971 14 024 3	LUEFTUNGSROHR	1M7		971 40 059 0	STUETZE	4L8
893 23 050 8	FEDERSCHIEBE					971 15 001 3	GREIFERHAEGER	1G4		971 40 060 0	DISTANZROHR	15B1,15D4
893 23 087 8	FEDERSCHIEBE	28G7				971 15 002 3	BUNDBUCHSE	1L7		971 40 065 0	ANSCHLAG	24J1,24J4
893 30 036 9	SCHIEBE 4,3	20L10,20L11				971 15 003 0	ANTRIEBSWELLE	1M8		971 40 066 0	ANSCHLAG	24H1,24J3
893 33 103 0	GEW.STIFT M6X6	25C3,27C3				971 15 009 3	NADELSCH.HALTER	1M5		971 40 068 0	GEWINDEPLATTE	24J2,24J4
893 52 093 0	GEW.STIFT M4X4	1K6				971 15 011 3	NADELSCHUTZ	1G5		971 40 069 3	GEWINDEPLATTE	24J1,24J3
893 52 105 0	GEW.STIFT M5X6	183,2C2				971 15 015 0	VORD.NADELSCHUTZ	1G5		971 40 075 0	EINLEGEBLECH MG	24H4
						971 15 016 3	GREIFERHAEGER	1K6		971 40 076 0	EINLEGEBLECH MG	24H4
						971 20 001 3	STICHPLATTE	1L1		971 40 077 0	EINLEGEBLECH MG	24H4
						971 20 001 4	STICHPLATTE	1M3		971 40 078 0	EINLEGEBLECH MG	24H4
						971 20 003 0	STICHOEHEINSATZ	1M3		971 40 079 0	EINLEGEBLECH MG	24H4
						971 20 006 0	MUTTER	1M1		971 40 080 0	EINLEGEBLECH MG	24H4
						971 20 008 0	STICHOEHEINSATZ	1M3		971 40 081 0	EINLEGEBLECH MG	24H4
						971 20 016 0	STICHOEHEINSATZ	1M3		971 40 082 0	EINLEGEBLECH MG	24H4
						971 20 017 4	STICHPLATTE KPL.	1M3		971 40 083 0	EINLEGEBLECH MG	24H4
						971 25 750 3	NORM.ZUBEHOER	12A5		971 40 084 0	EINLEGEBLECH MG	24H4
						971 25 551 3	NORM.ZUBEHOER	12A11		971 40 085 0	EINLEGEBLECH MG	24H4
						971 40 001 0	STAEENDER	8F2				
										971 40 086 0	EINLEGEBLECH MG	24H4
										971 40 087 0	EINLEGEBLECH MG	24H4
										971 40 088 0	EINLEGEBLECH MG	24H4
										971 40 090 0	VENTILPLATTE	11M10
										971 40 091 0	DISTANZSTUECK	9L3,11L11
										971 40 093 0	KONSOLE	8A3,24K2,24K4
										971 40 093 4	KONSOLE	8A3,24K4
										971 40 094 0	PLATTE	9J10
										971 40 192 3	KLEMMSTUECK	14E8,14F11
										971 40 193 0	WELLE	14F10
										971 40 096 0	DISTANZSTUECK	8B4,24L4
										971 40 097 0	FUEHRUNGSLEISTE	8A3,24K3
										971 25 750 3	NORM.ZUBEHOER	12A5
										971 25 551 3	NORM.ZUBEHOER	12A11
										971 40 001 0	STAEENDER	8F2
										971 40 002 3	STUETZSAEULE	8D10,1508
										971 40 003 0	ZENTRIERSCHRAUBE	8G9,8610
										971 40 004 0	ZENTRIERSTUECK	8G9
										971 40 005 0	DISTANZHUELSE	8C9,8C10
										971 40 006 0	LAGERBOLZEN	9L6
										971 40 007 3	LAGERHUELSE	9L6
										971 40 008 0	SCHALTFAHNE	9L6
										971 40 009 0	SCHALTRING	9L6
										971 40 010 4	SCHALTRING	9L6
										971 40 011 0	DREHFEDER	9K6
										971 40 012 0	HALTER	11C10
										971 40 013 0	STEBHALTER	8J12
										971 40 014 0	KABELHALTER	11J11
										971 40 018 3	RUNDPLATTE	8M3
										971 40 020 0	RASTERBLECH	8L5,9K2
										971 40 021 0	WINKEL	9J3
										971 40 023 0	ANSTANDSSCHIEBE	8K5,8L5
										971 40 024 0	DRUCKFEDER	8L5
										971 40 025 3	FUSSSTRIIT	8K7
										971 40 026 0	SCHWENKBOLZEN	8H10
										971 40 027 0	SPANNHEBEL	8H10
										971 40 028 0	RIEMENSPELLER	8H12
										971 40 029 0	ANSCHLAGBOLZEN	8G9
										971 40 030 0	STUETZBOLZEN	8F2,8F7
										971 40 031 0	AUFLAGEPLATTE	8F2
										971 40 033 0	WINKEL	9J3
										971 40 034 3	TAEGER	8D4
										971 40 037 3	TAEGER	8F6
										971 40 039 0	ANSCHLAG	8D4,8D6
										971 40 041 0	STECKERHALTER	9E5
	</											

Ersatzteilliste. Spare parts. Pièces de rechange. Piezas de repuesto.

Teile-Nr.	Benennung	Teile-Nr.	Benennung	Teile-Nr.	Benennung	Teile-Nr.	Benennung	Teile-Nr.	Benennung	Teile-Nr.	Benennung
971 40 068 0	GEWINDEPLATTE 24J2,24J4	971 40 136 0	GEHAUESEARM 5H4	971 40 231 3	LAGEK 14H2	971 41 196 0	WINKEL 17/1C6	971 43 102 4	GEN.ARM 5B11	971 44 085 0	LAUFROLLE 6L9
971 40 069 3	GEWINDEPLATTE 24J1,24J3	971 40 137 0	SPANNSCHIEBE 15B6,15B2,18E3,23E4	971 40 232 3	WELLE 14K2	971 41 200 0	SPITZE 17/1F6	971 43 751 4	NAEMMASCHINE 1A11	971 44 086 0	OBERMESSEN 4C1,4F3,4F7,4F11,12F9,13F9
971 40 075 0	EINLEGEBLECH MG 24H4	971 40 139 0	BUEGEL 4F10	971 40 235 0	STELLRING 14K2	971 41 205 0	LASCHE 17/1E5	971 44 002 0	LAUFROLLE 6C9	971 44 087 0	UNTERMESSE 4D3,4F7,4E11,12S9,13G9
971 40 076 0	EINLEGEBLECH MG 24H4	971 40 157 4	STEMPELSTANGE 3E2	971 40 237 0	AUSLEGEN 14K3	971 41 206 0	LASCHE 17/1F6	971 44 003 0	LAUFROLLE 6C9	971 44 088 3	KEILRIEMENSCH. 6E1,6F1
971 40 077 0	EINLEGEBLECH MG 24H4	971 40 175 0	EINLEGEBLECH MG 24H4	971 40 238 0	PLATTE 14K3	971 41 863 4	NAEGUTHALTER 4C3,17A17	971 44 004 3	KEILRIEMENSCH. 6C2	971 44 089 3	KEILRIEMENSCH. 6F3
971 40 078 0	EINLEGEBLECH MG 24H4	971 40 176 0	EINLEGEBLECH MG 24H4	971 40 239 3	HEBEL 14F7	971 41 864 4	NAEGUTHALTER 4C3,17A5	971 44 005 3	KEILRIEMENSCH. 6C2	971 44 092 0	KLEMME 4D5,4D9
971 40 079 0	EINLEGEBLECH MG 24H4	971 40 176 0	EINLEGEBLECH MG 24H4	971 40 240 0	ABWEISER 14C9	971 41 866 4	NAEGUTHALTER 4C10,17A5	971 44 006 3	KEILRIEMENSCH. 5H7,6C3	971 44 120 0	DRUCKPLATTE 4G7
971 40 080 0	EINLEGEBLECH MG 24H4	971 40 177 0	EINLEGEBLECH MG 24H4	971 40 241 0	KLOBEN 14G7	971 42 050 3	BLINDSTECKER 9K7	971 44 007 0	BUCHSE 3C2	971 44 121 3	MESSERTRAEGER 4D7,4D11
971 40 081 0	EINLEGEBLECH MG 24H4	971 40 178 0	EINLEGEBLECH MG 24H4	971 40 759 3	UMBAUSATZ 27D4	971 42 079 3	STAENDERFUSS 25L3,26L3,27L3	971 44 008 0	BUCHSE 3B2	971 44 122 0	WINKEL 4D6
971 40 082 0	EINLEGEBLECH MG 24H4	971 40 179 0	EINLEGEBLECH MG 24H4	971 41 001 0	HALTER 16E3	971 42 081 3	FUEHRUNGSBOCK 25H11,26H11,27H11	971 44 009 3	LAUFROLLE 6E3	971 44 123 0	LEITSTUECK 4E5
971 40 083 0	EINLEGEBLECH MG 24H4	971 40 180 0	EINLEGEBLECH MG 24H4	971 41 003 0	DRUCKFEDER 16B6,16E3,16E10,16L2,16L6,16L10,17E2,17E16,17A2	971 42 081 4	FUEHRUNGSBOCK 25H11,26H11,27H11	971 44 012 0	FUEHRUNGSBUCHSE 4G3,4G7,4G11	971 44 124 3	BLASROHR 4E5,4E9
971 40 084 0	EINLEGEBLECH MG 24H4	971 40 181 0	EINLEGEBLECH MG 24H4	971 41 005 0	HALTER 16E6,17F14	971 42 084 0	PLATTE 25G11,26G11,27G11	971 44 013 0	MITNEHMER 3F2,4C6,4C10,4D3,12F10,13F10	971 44 125 0	VERSTAERKUNG 4F6
971 40 085 0	EINLEGEBLECH MG 24H4	971 40 182 0	EINLEGEBLECH MG 24H4	971 41 006 0	HALTER 16K6,16K10	971 42 085 0	VERBUNDSTANGE 25G11,26G11,2	971 44 014 0	UNTERMESSE (HSS) 4F2,4F3,4F7,4F11	971 44 126 0	LEITSTUECK 4F11
971 40 086 0	EINLEGEBLECH MG 24H4	971 40 183 0	EINLEGEBLECH MG 24H4	971 41 008 0	HALTER 16D10,16K2	971 42 085 0	VERBUNDSTANGE 25G11,26G11,2	971 44 015 3	MESSERTRAEGER 4E2,4E6,4E10	971 44 200 4	SCHERKOPF 4A3,4G4
971 40 087 0	EINLEGEBLECH MG 24H4	971 40 184 0	EINLEGEBLECH MG 24H4	971 41 032 0	SCHLUESSEL 16B2,16B6,16B9,16H2,16H6,16H10,17B2,17B14,17B2	971 42 086 3	STIRNPLATTE 25G10,26G10,27G10	971 44 016 3	MESSERTRAEGER 4E3	971 44 201 4	SCHERKOPF 4G12
971 40 088 0	EINLEGEBLECH MG 24H4	971 40 185 0	EINLEGEBLECH MG 24H4	971 41 060 4	NAEGUTHALTER 16F5	971 42 088 0	WINKEL 25H11,26H11,27H11	971 44 018 0	MESSER (HSS) 4F11,4E7,4E3	971 44 751 4	BESCHNEIDER 3E11
971 40 090 0	VENTILPLATTE 11M10	971 40 191 0	PLATTE 14C11	971 41 061 4	NAEGUTHALTER 16F9	971 42 089 4	LENKROLLEPL 25M3,26M3,27M3	971 44 019 0	LEITSTUECK 4E2	971 45 025 3	BUCHSE 1B3
971 40 091 0	DISTANZSTUECK 9L3,11L11	971 40 192 3	KLEHMSTUECK 14E8,14F11	971 41 062 4	NAEGUTHALTER 16M1	971 42 751 4	STAPLER ST-1/0 25A11	971 44 021 0	SPANNKLOBEN 4J3,4J7,4J11	971 45 028 0	DECKEL 1B01
971 40 093 0	KONSOLE 8A3,24K2,24K4	971 40 193 0	WELLE 14F10	971 41 063 4	NAEGUTHALTER 17F14,17H11	971 42 752 4	STAPLER ST-2/0 26A11	971 44 022 0	BOLZEN 4J3,4J7,4J11	971 45 029 0	DISTANZROHR 1B21,23D2
971 40 094 0	PLATTE 9J10	971 40 194 3	SCHLITTEN 14G11	971 41 065 3	HEBEL 17B16	971 42 754 4	STAPLER ST-1/0 25A11	971 44 023 0	TRAEGER 4D2	971 45 031 3	HALTERSEGMENT 21H7
971 40 095 3	LEISTE 8A3,24K3	971 40 195 0	MESSERTRAEGER 14G11	971 41 066 3	HEBEL 14B16	971 42 755 4	STAPLER ST-2/1 26A11	971 44 024 0	HALTER 4D2	971 45 032 3	HALTERSEGMENT 19H7,20H7,22H7
971 40 096 0	DISTANZSTUECK 8B4,24L4	971 40 196 0	MESSE 14E8	971 41 069 0	BUEGEL 17C15,17G1,17I161	971 42 756 4	STAPLER ST-2/0 27A11	971 44 025 0	KLEMMRING 4J2,4J6,4J10	971 45 033 4	HALTERSEGMENT 22H7
971 40 097 0	FUEHRUNGSLEISTE 8A3,24K3	971 40 197 0	ACHSE 16G11	971 41 070 0	KLOBEN 17C15	971 42 757 4	STAPLER ST-3/1 27A11	971 44 026 0	BUEGEL 3F3	971 45 042 0	ANSATZSCHRAUBE 9G7,18D2,18H7,20G7,21G7,23H8
971 40 098 3	GEGENHALTER 8B3,24L3	971 40 198 0	LEISTE 14F11	971 41 071 0	FEDER 17D16	971 43 001 0	STECKERHALTER 9E2	971 44 027 3	BUCHSE 4C1,4C5,4C9	971 45 043 0	DRUCKFEDER 18H7,19H7,20H7,21G7,22H7,23H8
971 40 101 4	WARTUNGSEINHEIT 11C7	971 40 200 0	LEISTE 14K11	971 41 072 0	FEDER 17D16	971 43 002 0	HALTERBLECH 9C4	971 44 031 3	SPANNKLOBEN 4H4,4H8,4H12	971 45 044 0	GELENKHEBEL 18D6,18D8,19D6,20D8,21D6,21D7,23D9
971 40 102 4	LUEFTUNG 50 HZ 11K12	971 40 201 0	HALTER 14J9	971 41 076 0	SCHANNIER 17C14	971 43 003 0	LAUFROLLE 6F9	971 44 032 0	BLASROHR 4J4,4J8,4J12	971 45 046 0	RAEHBOLZEN 18D10,18E6,19D10,19E6,20D10,20E6,21D10,21E6,22E7,23E10
971 40 104 4	REGELGETRIEBE 8M10	971 40 202 0	LEISTE 14D5,14E8	971 41 081 4	NAEGUTHALTER 16L5	971 43 004 0	LAUFROLLE 6F9	971 44 034 0	DRUCKPLATTE 4G3,4G11	971 45 048 0	SPANNBRUECKE 18E7,18E9,19E7,19E8,20E7,20E9,21E7,21E9,22E7,23E9
971 40 106 4	FUSSTREIT 8L7,9K6	971 40 203 0	LAGER 14D8	971 41 082 4	NAEGUTHALTER 16M9	971 43 005 0	LAUFROLLE 6F9	971 44 035 0	LAGER 4H3,4H7,4H11	971 45 049 0	LAGERBOCK 18D9,18E6,21D9,21E6
971 40 107 4	LUEFTUNG 60 HZ 11K12	971 40 204 0	WELLE 11F1,14G6	971 41 091 0	HALTER 17F14,17G1,17I161	971 43 006 0	FUEHRUNGSROLLE 6F7	971 44 036 0	SCHIEBE 4G3,4G7,4G11,4H3,4H7,4H11	971 45 050 0	HEBEL 18C9,18D7,21C7,21C9
971 40 109 4	REGELGETRIEBE 9K9	971 40 205 0	TRANSPORTRAD 14F6	971 41 092 0	DRUCKFEDER 17D2,17D14,17I102	971 43 007 0	ROLLE 5D9,5E3,5F9	971 44 037 3	GEWICHT 4L3	971 45 051 0	ACHSE 18F6,18F9,19F6,19F8,20F6,20F7,21F6,21F8,22E6,22E8
971 40 110 4	WARTUNGSEINHEIT 11D7	971 40 206 3	HEBEL 14D8	971 41 111 0	LAGER 17E3	971 43 008 0	GLEICHSTROMMAGNET 5B1,5B7	971 44 040 3	GEGENGEWICHT 3C7	971 45 052 0	DISTANZROLLE 18F7,18F8,19E8,19F6,20E8,20F7,21E8,21F7
971 40 111 3	ROHR 4E9	971 40 207 0	GLEITBLECH 14F5,14L8	971 41 117 0	FUEHRUNG 17E6	971 43 009 0	SCHENKARM 11C3	971 44 041 0	SCHIEBE 3C3	971 45 054 4	SCHNENPLATTE 18E8,19E8,20E7,21E8,21E9,22E7,23E9
971 40 112 0	WINKEL 4G10	971 40 208 0	BRUECKE 14D8	971 41 118 0	PLATTE 17E6	971 43 010 0	ACHSE 5H11,11D7,11D5	971 44 042 3	KEILRIEMENSCHIEBE 6D1	971 45 055 4	ZWISCHENPLATTE 18E8,19E8,20E7,21E8,21E9,22E7,23E9
971 40 113 0	BOLZEN 4G11	971 40 209 0	MESSE 14D8	971 41 119 0	MUTTER 17B3,17B5,17E3,17I161	971 43 011 0	GLEICHSTROMMAGNET 5B1,5B7	971 44 043 3	KEILRIEMENSCHIEBE 6D3	971 45 056 0	LAGERBOCK 18D9,18E6,21D9,21E6
971 40 114 2	FUEHRUNG 15B10	971 40 210 0	LEISTE 14C5,14D8	971 41 120 0	LEISTE 17B5,17I161	971 43 012 0	WELLE 5B7	971 44 044 3	KEILRIEMENSCH. 5E5,6E3	971 45 057 0	LAGERBOCK 18D9,18E6,21D9,21E6
971 40 115 0	AUSLÖSERROHR 15G10	971 40 211 0	PLATTE 14D5	971 41 121 0	LEISTE 17B5	971 43 013 0	WELLE 5B1	971 44 045 3	KEILRIEMENSCH. 6E1	971 45 058 0	HEBEL 18C9,18D7,21C7,21C9
971 40 116 3	AUSLÖSERBALKEN 15B10	971 40 212 0	PLATTE 14D8	971 41 124 0	AUFLAGEBOCK 17F2,17I161	971 43 014 0	LAGERBOLZEN 5D4,5E9	971 44 046 0	LAUFROLLE 6C9	971 45 059 0	ACHSE 18F6,18F9,19F6,19F8,20F6,20F7,21F6,21F8,22E6,22E8
971 40 118 0	BUCHSE 15B10	971 40 213 0	ACHSE 14C5	971 41 125 0	GLEITPLATTE 17F2	971 43 015 3	HEBEL 5D9,5E3,5F9	971 44 047 0	LAUFROLLE 6D9	971 45 060 0	WINKEL 4D6
971 40 119 0	DISTANZBUCHSE 15B6,15B2,18C6,18C8,18C6,18C8,19C6,19C8,20C6,20C8,21C6,21C8,22C6,22C8,23C7,23C9	971 40 214 0	LEITBLECH 14D5	971 41 128 0	HEBEL 14H5	971 43 016 0	SCHIEBE 5F11,5J8,5K11,5L7,11B2,11F2	971 44 048 0	LAUFROLLE 6D9	971 45 061 0	WINKEL 4D6
971 40 120 3	MOTORHALTER 8J10	971 40 215 0	STANGE 14E5	971 41 129 0	EXZENTER 17D3	971 43 017 0	HUELSE 5G11,5J7,11C2	971 44 049 0	LAUFROLLE 6D9	971 45 062 0	DISTANZROLLE 18F7,18F8,19E8,19F6,20E8,20F7,21E8,21F7
971 40 121 0	HALTERSCHIEBE 15C6	971 40 216 0	ANSCHLAG 14F5	971 41 130 0	KLOBEN 17G1,17I161	971 43 018 0	ACHSE 11B5,11F5	971 44 050 3	BLINDSTECKER 9K7	971 45 063 0	SCHNENPLATTE 18E8,19E8,20E7,21E8,21E9,22E7,23E9
971 40 122 0	VERBUNDPLATTE 15A6	971 40 217 0	PLATTE 14B8	971 41 131 3	HEBEL 17B3	971 43 019 0	ACHSE 5K7	971 44 051 0	FEDER 4J2,4J5,4J9	971 45 064 0	WINKEL 4D6
971 40 123 0	AUFHAENGER 15B4	971 40 218 0	ABWEISER 14C11	971 41 132 3	HEBEL 17B3	971 43 020 0	ACHSE 5K7	971 44 052 0	DECKEL 4J2,4J6,4J10	971 45 065 4	ZWISCHENPLATTE 18E8,19E8,20E7,21E8,21E9,22E7,23E9
971 40 126 0	SCHIEBE 24H1,24H2	971 40 219 3	HALTER 14M8	971 41 133 0	HEBEL 17E6	971 43 021 0	DICHTPLATTE 5F4	971 44 053 0	DECKEL 4J2,4J6,4J10	971 45 066 0	WINKEL 4D6
971 40 129 3	HALTER 9L6	971 40 220 3	TRAEGER 14G4	971 41 134 0	AUFLAGEBOCK 17F2,17I161	971 43 022 0	STREBE 11D5	971 44 054 0	STOPFEN 4L3	971 45 067 0	WINKEL 4D6
971 40 130 0	HUELSE 15B10	971 40 224 0	PLATTE 14H5	971 41 135 0	GLEITPLATTE 17F2	971 43 023 0	SCHENKARM 11C3	971 44 055 0	LAUFROLLE 6C9	971 45 068 0	WINKEL 4D6
971 40 131 0	SCHNECKE 5H6	971 40 225 0	LAGER 14L4	971 41 136 0	AUFNAHME 17K4,17I161	971 43 024 0	KLEMMRING 11B5,11F5	971 44 056 0	LAUFROLLE 6D9	971 45 069 0	WINKEL 4D6
971 40 133 0	SCHNENKARMLAGER 8F8	971 40 226 3	KLEMMKLOBEN 14L7	971 41 137 0	FUEHRUNG 17E6	971 43 025 3	KEILRIEMENSCHIEBE 6C2	971 44 057 0	LAUFROLLE 6C9	971 45 070 0	WINKEL 4D6
971 40 134 0	SCHNENKARMLAGER 8F8	971 40 227 3	KLEMMKLOBEN 14K3	971 41 138 0	HEBEL 17E2	971 43 026 0	SCHENKARM 11C3	971 44 058 0	LAUFROLLE 6C9	971 45 071 0	WINKEL 4D6
971 40 135 0	SCHNENKARM 5H9	971 40 228 0	KLOBEN 14K6	971 41 139 0	ROLLE 14L7	971 43 027 0	ACHSE 5H11,11D7,11D5	971 44 059 0	LAUFROLLE 6C9	971 45 072 0	WINKEL 4D6
		971 40 230 3	ROLLE 14L7	971 41 194 0	ANSATZMUTTER 17I14	971 43 028 0	ACHSE 5K7	971 44 060 0	LAUFROLLE 6C9	971 45 073 0	WINKEL 4D6
				971 41 195 0	SCHIEBE 17I161	971 43 029 0	ACHSE 5K7	971 44 061 0	LAUFROLLE 6C9	971 45 074 0	WINKEL 4D6

Änderungen vorbehalten

Ersatzteilleiste. Spare parts. Pièces de rechange. Piezas de repuesto.

Teile-Nr.	Benennung	Teile-Nr.	Benennung	Teile-Nr.	Benennung	Teile-Nr.	Benennung	Teile-Nr.	Benennung	Teile-Nr.	Benennung						
	19E10	971 45 804 4	SEGMENTSATZ	22F6	972 44 056 0	MESSER	29F6	972 44 121 0	LAGERBOLZEN	29A1,29G9	980 40 100 0	ARM	2H9	980 40 346 0	SCHALTLEISTE	11L12	
	20E10,21E10,23E10	971 46 075 0	SCHEIBE	17,1K4	972 44 059 0	WINKEL	20A5,20D5	972 44 122 0	SÄULE	29A3,29B12	980 40 100 1	ARM		980 40 350 3	ANTRIEBSRAD	8J10	
971 45 056 0	LEISTE	18H7,19H7,20H7,21H7,22H7			972 44 060 0	GEW.STIFT	28A5	972 44 750 4	KETTFAEDNTR.KPA1-4	17G18	980 40 100 4	OBERTEIL KPL.	2H2	980 40 351 0	KEILRIEMENSCH.	8K10	
971 45 057 0	ABDECKBLECH	18G9,19G9,20G9,21G9,22G9,23J9			972 44 061 0	GEW.STIFT	28A5	972 44 751 4	EINSCHNEIDETR.	29A12	980 40 101 0	UNTERARM	2H9	980 40 352 0	KLEMMRING	8M10	
971 45 059 0	WELLE	20D10,20E8,21C10,21E8,23D11,23E8			972 44 062 0	SCHEIBE	20J8	972 44 758 4	KETTFAEDNTR.KPA1-6	17G18	980 40 104 3	GREIFERWELLE	2L7	980 40 353 0	BOLZEN	8J9	
					972 44 063 0	DAEMPFSCHEIBE	28J9,29E8	972 45 001 0	ROLLE	20M10,20L10,22L10,22M10,24E2		980 40 105 0	VORLEGEWELLE	2L9	980 40 354 0	UMLAUFRAU	8J9
					972 44 064 0	GEWINDEPLATTE	14G5,29A3,29E3,29B6,29F11,29K11	972 45 002 3	ZAHNSTUECK	14J6,20K11,20L10,22K11,22L10,24E2		980 40 106 0	STENBOLZEN	1K9,2K9,3H7	980 40 355 3	ZAHNRAD	8J10
											980 40 107 0	STENBOLZEN	1K8,2K8,3J7	980 40 360 3	REIBSCHEIBE	8H9	
971 45 068 0	VERB.LEISTE	18K6,19J6,20J5,21J6,22J6,22H12			972 44 066 0	PASSCHR.	28E5,28H5,28H6	972 45 003 0	EXZENTERMUTTER	20K11,20L10	980 40 109 0	MITTELTEILHALTER	2H5	980 40 363 0	RIEMEN SP.KLOBEN	8G12	
					971 48 005 4	VERTEILERKASTEN	9F4	972 44 070 3	SCHLITTEN	29H5	980 40 117 3	STIRNRAD	2L9	980 40 366 0	DRUCKRING	8H10	
971 45 081 3	TRAEGERPLATTE	23F5			971 48 006 4	ENDTASTER	9G1	972 44 071 3	ANSCHLAG	29L5	980 40 125 0	STICHPLATTE	2H6	980 40 367 3	KREUZLOCHMUTTER	8G10	
971 45 083 0	ZAHNRAD	23F4			971 48 008 4	ZULEITUNG	9E7	972 44 074 0	SCHALTSTUECK	29K6	980 40 128 0	WINKEL	9A4	980 40 371 0	GEGENGEWICHT	8K10	
971 45 084 0	ZUGSTANGE	23G2,23G5			971 48 009 4	TISCHHALTER	9K6	972 44 075 0	SCHALTHEBEL	29L5	980 40 138 3	STELLRING	2L7,2L8,2K6	980 41 007 0	SCHARNIERSTIFT	16C2,16C5,	
971 45 085 3	BUCHSE	23E3			971 48 010 4	VENTIL	11E11,11D8	972 44 076 0	WINKEL	29F8	980 40 141 0	WINKEL	9C4				
971 45 086 3	DECKEL	23D5			971 48 011 4	VENTIL	11E11,11D8	972 44 077 0	FUEHRUNG	29F8	980 40 147 3	MUELLERBLASROHR	4/1B7	980 41 008 0	SCHENKELFEDER	16C2,16C5,	
971 45 088 3	VERSCHIEBESTCK.	23G2,23H6,23J4			971 48 012 4	STECKERBESCHN.	9M2	972 44 078 0	ANSCHLAGHULSE	29F8	980 40 148 0	MUELLSCHLAUCH	4/1C7,4/1D10				
					971 48 013 4	STECKER GEN.NAHEM.	9E2	972 44 079 3	HALTER	18J2,29K7	980 40 150 4	VERST.NAHEGUTHALTER	21B10	980 41 025 3	SPANNKLOBEN	25J11,26J11	
971 45 089 0	LEISTE	23J5,23K2			971 48 014 4	FADENWAECHTER-STECKER	9C6	972 44 080 4	KETTFAEDNTRHENNER	17L16	980 40 150 0	OBERRARM	3F7	980 41 027 0	EXZENTERBOLZEN	25H11,26H11	
971 45 091 3	HALTERSEGMENT	23G10			971 48 016 4	STECKERNAHEM.	9C6	972 44 081 3	HALTEBLECH	17L16	980 40 150 4	OBERTEILKP	3G7				
971 45 092 1	LAGENBOCK	23F8,23F10			971 48 017 4	EL.ANSCHLUSS	9H12,25M9,26M9,27M10	972 44 082 3	MESSERTRAEGER	17M13	980 40 151 0	UNTERARM	3H7	980 41 034 0	SCHARNIERSTUECK	16C2,16C5,16C9,16J2,16J6,16J10	
971 45 093 0	LAGENBOCK	23D7,23D8						972 44 083 3	ZUGSTANGE	17M13	980 40 154 0	STEMPEL	4B8,12E10,13E10	980 41 035 0	SCHARNIERBOCK	16C2,16C5,16C9,16J2,16J6,16J10	
971 45 094 0	HEBEL	23C9,23D7			971 48 751 4	EL.EINHEIT	10J7	972 44 084 3	ZUGSTANGE	17M13	980 40 156 0	BUCHSE	3E2				
971 45 095 0	ACHSE	23F7,23F9			971 48 752 4	EL.EINHEIT	10J7	972 44 085 0	MESSER	17M14	980 40 157 3	STEMPELSTANGE	28F2	980 41 040 0	KONTAKTWINKEL	16F1,16F5,16F9,16M1,16M5,16M9,17F14,17J2,17J12	
971 45 096 0	SKALENLEISTE	23F8			971 48 753 4	EL.EINHEIT	10J7	972 44 086 0	MESSER	17M13	980 40 160 3	KURBEL	3C3				
971 45 150 4	KETTENFAENGER	24D6			971 48 754 4	EL.EINHEIT	10K7	972 44 087 0	MESSER	17M14	980 40 160 4	KUNDEL	3B3	980 41 205 0	ANSCHLAGWINKEL	16D4,16D7,16D11,18F10,18J6,19G11,19H6,20G11,20G5,21G11,21H6,22G11,22H6	
971 45 151 3	GRUNDOPLATTE	24F7			971 48 755 4	EL.EINHEIT	10K7	972 44 088 0	AUSLÖSEHEBEL	17J17	980 40 161 0	BOLZEN	3B3				
971 45 155 3	BUEGEL	24D7			972 25 750 3	NORM.ZUBEHOER	13A5	972 44 089 0	GRUNDOPLATTE	29G2	980 40 170 0	LAUFROLLE	6D9	980 41 321 0	LAGENBOCK	17C15,17G2,17J62	
971 45 158 0	DREHFEDER	24F6			972 25 751 3	NORM.ZUBEHOER (MIT BESCHNEIDER)	13A11	972 44 090 4	GRUNDOPLATTE	29G2	980 40 171 0	LAUFROLLE	6D9				
971 45 159 0	HEBEL	24E6						972 44 091 4	HEBEL	29M8	980 40 172 0	LAUFROLLE	6D9	980 41 328 0	WELLE	17G4,17J64	
971 45 160 0	FAENGER	24G7			972 40 001 3	STUETZSAEULE	15D8	972 44 092 3	HEBEL	29L9	980 40 173 0	LAUFROLLE	6E9	980 41 336 0	PLATTE	24F8	
971 45 161 0	KLINKE	24E6			972 40 002 0	STICHPLATTE	2H5	972 44 093 3	HEBEL	29L9	980 40 174 0	LAUFROLLE	6E9	980 41 349 0	DRUCKFEDER	16C5,16C9,16D1,16J8,16J9,16K1,19E8,19E6,20E6,20F8,21E6,21E8,22E6,22E8,23E7,23E9,17J102	
971 45 162 0	ZUGFEDER	24F7			972 40 010 3	DELTOPF	2E9	972 44 094 3	HEBEL	29F3	980 40 175 0	LAUFROLLE	6E9				
971 45 163 0	PLATTE	24F5			972 43 007 0	NADELFUEHRUNG	2H5	972 44 095 0	ANSCHLAG	29G4,29L9	980 40 176 0	LAUFROLLE	6E9				
971 45 164 3	AUSLÖSEBUEGEL	24G5			972 43 010 0	BEHAELTER	2M7	972 44 096 0	ZUGSTANGE	29E4	980 40 177 0	LAUFROLLE	6E9				
971 45 165 0	ANSCHLAG	19J7,20F12,20G11,20J6,21F12,21G11,21J7,22F11,22G11,22J7			972 43 751 4	NAHMASCHINE	2A11	972 44 101 0	SPITZENBESCHN.	29H12	980 40 189 3	KOPFDECKEL	2F4	980 41 387 2	AUFNAHMEBOLZEN	16D1,16D6	
					972 43 753 4	972 - MA		972 44 102 0	SPITZENBESCHN.	29C2	980 40 190 3	FADENSCHNUNG	2G5	980 41 443 0	DISTANZBOHR	17F17	
					972 44 010 0	UNTERMESSEHALTER	29F6	972 44 103 0	SPITZENBESCHN.	29C2	980 40 191 0	STICHPLATTE	2G9	980 42 001 0	GLEITSTANGENLAGER	25H5,26H,27H5	
					972 44 012 0	MESSER	29F7	972 44 104 3	OBERMESSEHALTER	29B1	980 40 210 0	KLOBEN	3E2,4A7				
971 45 167 2	AUFNAHMEBOLZEN	19F9,19G11,20F9,22F9			972 44 014 0	WINKEL	29D6	972 44 105 3	OBERMESSEHALTER	29G10	980 40 210 0	ZYLINDERKLOBEN	8L10,8L12,11M12,11M12	980 42 002 0	STEG	25E5,26E5,27E5	
					972 44 015 3	AUFNAHME	29M5	972 44 106 3	PLATTE	29F5	980 40 041 0	HALTEWINKEL	11J12	980 42 003 0	LAGERARM	25C5,26C5,27C5	
971 45 168 2	AUFNAHMEBOLZEN	21F9			972 44 019 0	LAGERBOLZEN	29F6	972 44 107 3	SPANNKLOBEN	29F5	980 40 048 0	TISCHHALTER	8A1,8A5	980 42 004 0	DISTANZSTUECK	25E5,26E5,27E5	
971 45 751 4	VERSTELLKOEPPER	18A4,18G1			972 44 020 0	ANSATZSCHN.	29F6	972 44 108 0	ECKENEINSCHNIDEN	29D5	980 40 049 0	BLATTFEDER	8A1,8A4	980 42 005 0	DISTANZSTUECK	25G5,26G5,27G5	
					972 44 023 0	WELLE	29E7	972 44 109 0	OB.MESSEHALTER	29E7	980 40 054 0	FUSS	8L3,12L1,12L7,13L7	980 42 006 0	ZWISCHENSTUECK	25G10,26G10,27G10	
971 45 752 4	VERST.NAHEGUTHALTER	18A11,18L9			972 44 024 0	BUCHSE	29M5	972 44 110 3	GEWINDEPLATTE	29F5,29G5,29J11,29L11	980 40 081 0	DUESE	4/1B7				
					972 44 028 0	HALTER	28H7	972 44 111 3	SPANNKLOBEN	29F1,29J1	980 40 098 2	FLANSCH	10L1,10L6	980 42 007 0	GLEITSTANGE	25G1,26G1	
971 45 753 4	VERST.NAHEGUTHALTER	19M9,19A11,22B10			972 44 029 0	WINKEL	28K5	972 44 112 0	BLASROHR	29F1,29M11							
					972 44 030 0	WINKEL	29E2	972 44 113 0	MESSE	29B1,29G10,29H10							
971 45 791 4	VERSTELLKOEPPER	23A5,23G5			972 44 033 3	SCHALTWINKEL	28L7	972 44 114 0	LAGENBOCK	28K8							
971 45 792 4	VERST.NAHEGUTHALTER	23A11,23M10			972 44 036 3	HALTER	28K5	972 44 115 0	MESSE	29B1,29G10,29H10							
					972 44 039 0	SCHNENKARM	28C8	972 44 116 0	LAGENBOCK	28K8							
					972 44 041 0	LAGENBOCK	29E9	972 44 117 0	SCHALTERPLATTE	29J5							
971 45 801 4	SEGMENTSATZ	21F7			972 44 042 3	BOLZEN	28H7	972 44 118 0	LAGER	29B2,29J10							
971 45 802 4	SEGMENTSATZ	19F5,20F6			972 44 043 0	WINKEL	28L4	972 44 119 0	UNTERM.HALTER	29C2,29H11							
971 45 803 4	SEGMENTSATZ	23F8			972 44 054 0	DISTANZSTUECK	28H7	972 44 120 0	BLATTFEDER	29C4,29J12							

Ersatzteilleiste. Spare parts. Pièces de rechange. Piezas de repuesto.

Teile-Nr.	Benennung	Teile-Nr.	Benennung	Teile-Nr.	Benennung	Teile-Nr.	Benennung	Teile-Nr.	Benennung	Teile-Nr.	Benennung			
993 03 145 0	SENKSCHR. M4x35	17/1H6		26H1,27H1		25A4,26A4,27A4		10M11,17F15,18K9,19J9,19K8,19K9,19K11,19L8,19L9,20J9,20K8,20K9,20K11,20L8,20L9,21J8,21J9,21K9,21K11,21L8,21L9,22J9,22K9,22K11,22L8,22L9,23K11,23L9,23L10,24E9,24E8,25B12,25G6,26D6,26B12,27B12,27D6,29K11	993 52 116 0	GEN.STIFT M5x8	3F2,3F3,4/1A7,4/1A8	993 91 104 7	ZYL.SCHR. M5x16	5F8,15A1,15B4,18E3,23E6,25A6,26A6,27A6
993 03 145 7	SENKSCHR. M4x35								993 54 511 7	SCHLAGMUTTER M4		993 91 104 8	ZYL.SCHR. M5x16	28M6
993 03 156 0	SENKSCHR. M5x10	1486		9F1,9M3,11M11		17J15			993 67 157 0	RAENDELSCHR. M6x12		993 91 106 7	ZYL.SCHR. M5x20	1J6,17B5,28M7,28M6
993 03 156 7	SENKSCHR. M5x10	14C11				25L7,26L7,27L7			993 67 157 7	RAENDELSCHR. M6x12		993 91 108 8	ZYL.SCHR. M5x20	14F11,28L7
993 03 177 7	SENKSCHR. M6x14	17/1F4							993 72 021 0	NIEET	17/1E6	993 91 108 7	ZYL.SCHR. M5x25	14F11,28L7
993 03 178 0	SENKSCHR. M6x16								993 90 400 8	SETZSCHR	12H10	993 91 110 8	ZYL.SCHR. M5x25	14L11
993 03 178 7	SENKSCHR. M6x16	14C11,25E3		25J11,26J11,27J11					993 91 080 7	ZYL.SCHR. M4x6	1F3,2J5,17D16,18J6,22N6,25B4,26B4,27B4	993 91 110 7	ZYL.SCHR. M5x35	14L11
		25G3,25G9,26E3,26G3,27E3,27G3,27G9							993 91 080 8	ZYL.SCHR. M4x6		993 91 110 8	ZYL.SCHR. M5x35	14L11
993 03 722 0	SENKSCHR. M3x4	18K6		25J7,26H7,27H7					993 91 081 7	ZYL.SCHR. M4x8	1G5,1K7,3H5,4B8,16B2,16B6,16B7,16B10,16C8,16D7,16M2,16H6,16H10,17B3,17B14,17C2,17E1,17/1C2,17/1B3,28K3	993 91 121 7	ZYL.SCHR. M6x8	16B2,16B3,16B6,16B10,17D16,18D10,18E7,19D10,20D10,21D10,23E8,23E11
993 03 722 7	SENKSCHR. M3x4	19J6,19L9,							993 91 081 8	ZYL.SCHR. M4x8		993 91 121 8	ZYL.SCHR. M6x8	
		25G3,25G9,26E3,26G3,27E3,27G3,27G9							993 91 082 7	ZYL.SCHR. M4x10	1G5,1K6,1K7,4H4,4H8,4H12,5B7,5H2,17D17,17F1,17H5,17/1H5,19G11,20G12,21G12,22G11,24F5,24F5,25B2,26B2,27B2,29C4,29J12	993 91 122 7	ZYL.SCHR. M6x10	14E10,14G4,25B12,26B12,27B12,28K5,29D2,29C5,29J11,29K11
993 04 000 0	ZYL.SCHR. M3x15x9	28E11							993 91 082 8	ZYL.SCHR. M4x10		993 91 123 7	ZYL.SCHR. M6x12	5M5,11E5,14H5,14K2,14M8,22K8,20K10,21J10,21K8,22F7,22F10,22J10,22K9,23G10,23J1,23K4,25J11,25G5,26J11,27J11,27F5,28H7,28K5,28G8,29D2,29C5,29D6,29F6
993 04 000 7	ZYL.SCHR. M3x15x9	28E11							993 91 083 7	ZYL.SCHR. M4x12	1L2,1G5,3D2,16F2,16F6,17F15,17K4,17/1K4,18C3,18E8,18F8,18J10,18J9,18K9,19E6,19F7,19J8,19J9,19J10,19J11,19K9,20L11,20E6,20E8,20G7,20J8,20J9,20J11,20K9,20L8,20L10,21E6,21F8,21J8,21J9,21J11,21K9,21L9,22E6,22E8,22F7,22J8,22J9,22J11,22K9,22L8,22L9,22L10,22L11,23C2,23G9,23J10,23J11,23K9,24D1,24D2,24H1,24H3,24H4,25B2,26B2,27B2,29F4,29L9	993 91 124 7	ZYL.SCHR. M6x16	8D4,8L9,9H10,9K11,14D8,14J4,14L7,16B11,16C1,16C9,16B5,16F4,16E7,16F11,16J1,16J5,16J9,16K5,16K9,17D4,17F2,17/1F3,17G2,18D7,18B8,18D9,19G9,19H7,20D8,20D9,20M7,21D7,21D9,21F9,21H9,22H9,23D10,23E8,23J,23J4,23J6,23K2,23K5,25B6,25C6,26B6,26C6,27B7,27C6,28G7,28F9,29E2,29J9,17/1F2,17/1G2
993 04 000 7	ZYL.SCHR. M3x15x9	28E11							993 91 083 8	ZYL.SCHR. M4x12		993 91 124 8	ZYL.SCHR. M6x16	16B9,14D8
993 06 094 0	ZYL.SCHR. M3x6	4E10							993 91 084 7	ZYL.SCHR. M4x16	182,9610,17C5,25B3,26B3,27B3	993 91 125 7	ZYL.SCHR. M6x18	14D8
993 06 094 7	ZYL.SCHR. M3x6	4D5,409							993 91 084 8	ZYL.SCHR. M4x16		993 91 125 8	ZYL.SCHR. M6x18	14L8,23E7,23F9,29F5
993 06 096 0	ZYL.SCHR. M3x10								993 91 085 7	ZYL.SCHR. M4x18	1A8,4J2,4J6,4J10,18D7,18D8,18D9,19D7,19D9,20D6,20D8,20D9,21D7,21D8,21D9,23D9,25D3,26D3,27D3	993 91 126 7	ZYL.SCHR. M6x20	184,1H5,284,3C4,8B4,14B8,14K6,17F17,17H17,18E9,18F6,18F7,18F8,18H4,18H3,19E6,19E8,19F6,19F8,19F9,20E8,20F6,20F8,21E6,21E8,21F7,22C6,22E9,24L4,25B7,25D12,26B7,26D12,27B7,27B12
993 06 096 7	ZYL.SCHR. M3x10	409,18K9,20M9,21M9,22M9							993 91 085 8	ZYL.SCHR. M4x18				
993 06 097 7	ZYL.SCHR. M3x8	19H7,20F11,20J6,21F11,21H7,22F11,22H7							993 30 037 0	SCHIEBE 5,3	25E1,25H3,26E1,26H3,27E1,27H3			
993 06 098 0	ZYL.SCHR. M3x16								993 30 037 7	SCHIEBE 5,3				
993 06 098 7	ZYL.SCHR. M3x16	1L7							993 30 038 0	SCHIEBE 6,4				
993 06 100 0	ZYL.SCHR. M3x20								993 30 038 7	SCHIEBE 6,4	17F17			
993 06 100 7	ZYL.SCHR. M3x20	14H8,14M4							993 31 073 0	ZYL.STIFT	17G1			
993 06 133 7	ZYL.SCHR. M4x5	16C7,16D4,16D11,18F10,19F12,19H6,20F12,20H5,21F12,21H6,22F11,11H11							993 34 054 0	GKT.MUTTER M3				
993 06 134 7	ZYL.SCHR. M4x6	5D7,5K1,903,11L3							993 34 054 7	GKT.MUTTER M3	29J5			
993 06 135 0	ZYL.SCHR. M4x8								993 34 056 0	GKT.MUTTER M4	2C2,4/1K9,4/1L10,17A3			
993 06 135 7	ZYL.SCHR. M4x8	265,5J2,17/1C6							993 34 057 0	GKT.MUTTER M5				
993 06 136 0	ZYL.SCHR. M4x10	11L12							993 34 057 7	GKT.MUTTER M5	2E7,29K6			
993 06 136 7	ZYL.SCHR. M4x10								993 34 059 0	GKT.MUTTER M8				
993 06 137 0	ZYL.SCHR. M4x12								993 34 059 7	GKT.MUTTER M8	8L5,8M6			
993 06 137 7	ZYL.SCHR. M4x12	507,5K1,8610,14L4							993 34 060 0	GKT.MUTTER M10				
993 06 140 0	ZYL.SCHR. M4x20								993 34 060 7	GKT.MUTTER M10	11D1			
993 06 140 7	ZYL.SCHR. M4x20	25H1,							993 41 120 8	RAENDELMUTTER M4	2F7			
									993 52 093 0	GEN.STIFT M4x4	29E2,29H11			

Ersatzteilliste. Spare parts. Pièces de rechange. Piezas de repuesto.

Teile-Nr.	Benennung	Teile-Nr.	Benennung	Teile-Nr.	Benennung	Teile-Nr.	Benennung	Teile-Nr.	Benennung	Teile-Nr.	Benennung
996 01 303 8	SICH.RING 18X1,5	11L4		998 88 106 0	PASZSCHEIBE 20x28x0,3	999 20 065 3	ANFAHRROLLE AN 9F2,9L4,	1506,18E3,	999 22 045 4	VENTIL 11K9,25K8,26K8,	
995 10 061 0	VERSCHLUSZSCHR.R14	11C7,	16E10,16K2,16K6,16K10,		5C2,502,507		11L11	23E4		27K8,28J2,28L2,	
		11F7	1702,17D16,17/102	998 88 111 0	PASZSCHEIBE 12x18x0,3	999 20 066 3	2-POL-UMSCHALTER 2A 1088,	29M8,29M8,	999 21 013 3	SPREITZNIET 29M8,29M8,	28E4,28G5
995 19 013 8	SPANNHUELSE 2X8	4E2,4E6,			8H11,		10E7,10F4,10F12	27M8	999 22 047 5	SCHLAUCHKLEMME 1A6	
		4E10		996 07 014 8	SICH.SCHEIBE 12	998 88 161 0	PASZSCHEIBE 12x18x0,5	5C4,5C10	999 20 066 5	KLINGELTRAFU 110V 10F4,	
995 34 013 5	GKT.MUTTER PG16A	984			8G11,14H2		5C4,5C10	10F8	999 20 075 8	HILFSCHUTZ 10H6	
995 34 061 7	GKT.MUTTER PG11x9		996 08 514 0	RILLENKUGELLAGER 107		998 88 210 0	PASZSCHEIBE 10x16x1	14L4	999 20 079 7	MIKROSCN. 985,905	
995 34 061 8	GKT.MUTTER PG11x9	11M4	996 08 520 0	RILLENKUGELLAGER 8K10		998 88 216 0	PASZSCHEIBE 20x28x1	14H2,	999 20 079 8	HEBEL 985,905	
996 01 081 8	SICHERUNGSRING 5x0,6		996 08 534 0	RILLENKUGELLAGER 2C7			1110,2E4		999 21 023 4	KUGELHALTER 501,5E7,11C1,	
996 01 082 8	SICHERUNGSRING 6x0,7	5D9,	996 08 866 0	RILLENKUGELLAGER 1L9,		998 91 014 0	SPRENGRING SB11	1D10,2E4		11E1	
		5E3,5F9,18D10,18E8,19D10,		11L0,2M8,2M10,2K8,2K9,8J9		998 91 205 0	SPRENGRING SW9	1L6	999 21 023 5	PICCOLOSCHLEIBE 8K11	
		19E7,20D10,20E8,21D10,21E7,				998 99 023 8	SICH.SCHEIBE 8	14E6	999 21 024 7	STERNGRIF 8C4,8J12,24M4	
		22D9,22E7,23E11		996 12 045 0	STELLRING 14	999 05 038 7	GKT.MUTTER M8x1	29E5	999 21 024 9	MAGNETSCHNEPPER 1L7	
996 01 084 8	SICHERUNGSR.8x0,8	1K2,	996 12 045 7	STELLRING 14	25D12,	999 05 042 0	GKT.MUTTER M12X1		999 21 025 6	KUPPLUNGSBELAG 8M9,8M10	
		11M12,18E3,18F1,18F3,18F4,		26D12,27D12		999 05 042 7	GKT.MUTTER M12X1	8G9,	999 21 075 7	GUMMIFUSS 8L2	
		18G1,23F3,23G1,23H6,23K4,					8G10		999 21 081 9	NUTMUTTER 5F11,5H8,5K11,	
		25C3,26C3,27C3		996 26 312 0	N-DICHRING 1K6	999 19 022 6	OELTOPF NR36	4K3,4K7,4K11	999 21 083 5	NUTMUTTER 5F11,5H8,5K11,	
996 01 085 8	SICHERUNGSR. 9x1	8J9	996 28 021 0	DICHRING 1G2		999 20 008 3	MIKROSCHALTER 28L5,29K5,	11H11,		5M7,11F5,11A2,	
996 01 086 8	SICHERUNGSR.10x1	5D4,5D9,	996 28 031 0	DICHRING 1E10			29F9	25M6,26M6,27M6	999 21 083 6	SICH.BLECH 5F11,5H8,	
		5F4	996 28 080 0	DICHRING 25J8,26J8,27J8		999 20 013 0	PILZTASTER 9A2			5K11,5M7,11F5,11F2,	
996 01 088 8	SICHERUNGSR.12x1	5F1,5F7,	996 35 025 0	DICHRING 1C7		999 20 020 1	ENDTASTER 9G1,9G12,25H1,	26H1,27H1		11B2,11B6	
		25G4,26G4,27G4	996 45 224 0	STUETZE 984		999 20 022 8	DREHSTROMSCHUETZ 10G9		999 22 001 4	3/ZWEGEVENTIL 11L9,28E2,	
996 01 091 8	SICHERUNGSR.15x1	187,28G,	996 51 045 0	SPANNHUELSE 8C10		999 20 024 5	DREHSTROMSCHUETZ 10H9			28F3	
		18D1,23C2	996 58 043 0	SCHARNTER 8M6		999 20 024 6	DREHSTR.SCH. D100-44/59		999 22 001 5	3/ZWEGEVENTIL 25D2,25J2,	
996 01 114 8	SICHERUNGSR.	8J9	996 76 050 0	KEGELROLLENLAG. 8G11,		999 20 026 8	DREHSTR.SCH. D100-44/59	10B5	999 22 002 5	OELER 11C8	
				5J8,5K11,5L7,11B2,11F2			10J7,10M1		999 22 003 4	DRUCKL.ZYLINDER 11J12	
996 01 303 8	SICH.RING 18X1,5	11L4		997 50 264 0	G-SICH.EINS. T20 10E1,	999 20 034 9	REIHENKLEMME 9F4		999 22 012 4	MIKROZYLINDER 2905,29K9	
996 02 113 8	SICH.RING 24X1,2	1M9,		10B5,10F1,10F5,		999 20 035 2	TRAGSCHIENE 9G3		999 22 012 6	MIKROZYLINDER 25G3,26G3,	
		1M10		10F9,12D3,12D9,		999 20 037 9	BUCHSENKLEMMSCH. 9G9,			27G2,27J2	
996 02 116 8	SICH.RING 28X1,2	5H6		1303,13D9		999 20 038 0	BEZ.STREIFEN 9G9,25M8,		999 22 012 7	MIKROZYLINDER 25G3,26G3,	
996 02 117 8	SICH.RING 30X1,2	15B10		997 50 270 0	G-SCHRAUBKAPPE 10A3,		26M8,27M8,28F10			27G3	
996 02 127 8	SICH.RING 47X1,75	187,		10B5,10E7,10F1,10F9		999 20 042 4	ISOLIERST. GEN. 10H5		999 22 014 3	DRUCKL.ZYLINDER 11J10	
		1810,28G,28I0,388,306		997 50 283 0	G-SICHERUNGSEINS.F0,53G	999 20 043 1	ABDECKKAPPE 28L5,29J5,	29F9	999 22 015 2	DRUCKL.ZYLINDER 2909	
996 02 144 8	SICH.RING 8K10			10F9,12E3,12E9,13E3,13E9		999 20 044 0	WUERGENIPPEL PG16 9F4		999 22 015 6	DRUCKL.ZYLINDER 25F3,	
996 06 010 0	KUGEL 1,588	4G3,4G7,		998 82 028 8	GREIFRING 4H3,4J6,4K4	999 20 048 2	STECKEREINS.HAN 16A 9C1,			26F3,27F3,28H10	
		4G11,4H3,4H7,4H11		998 85 081 0	DICHRING 1XD-16-4 1H4	999 20 048 8	SPEHRBÖLZEN 9E11,10K1		999 22 015 8	DRUCKL.ZYLINDER 25G7,26G7	
996 06 017 0	KUGEL 3,969	1C5,2C5		998 85 115 0	SIMMERRING 9x18x6 1M7	999 20 100 8	AUSSCHALTER 10A8,10E8		999 22 020 1	VENTIL 11L9,28F2,28F3	
996 06 020 0	KUGEL 4,762	20F10		998 86 007 0	O-RING 185,286,385	999 20 102 9	STEUERSCHALTER 9H6,9H10,		999 22 033 4	MIKROZYLINDER 17H14	
996 07 003 8	SICH.SCHEIBE 17C14			998 86 014 0	O-RING 4,5 2L7,3B5	999 20 102 9	STEUERSCHALTER 9H6,9H10,		999 22 035 0	BEFESTIGUNG 28G8,29D3,	
996 07 004 8	SICH.SCHEIBE 1,9			998 86 053 0	O-RING 10 1A2,2A2	999 20 104 6	WUERGENIPPEL PG9 28M4,		999 22 035 3	MIKROZYLINDER 20 25K4,	
996 07 006 8	SICH.SCHEIBE 3,2	1B8,		998 86 068 0	O-RING 11 1G1	999 20 104 6	WUERGENIPPEL PG9 28M4,			26K4,27K4,	
		1D1,2D2,4J3,4J7,4J11,24E6		998 86 072 0	O-RING 12 2J1	999 20 105 9	MOT.SCHUTZSCH. 9M12			28G6,29B6	
996 07 007 7	SICH.SCHEIBE 4			998 86 073 0	O-RING 12 1L6	999 20 108 8	D-TRENNTRAFU 9M11		999 22 038 1	FILTER 11D10	
				998 86 260 0	O-RING 30 1H2	999 20 123 4	WIDERSTAND 6C1		999 22 038 2	DRUCKREGLER 11C9	
996 07 007 8	SICH.SCHEIBE 4	17K16,		998 86 320 0	O-RING 36 1J6,14F6	999 20 130 3	MOT.SCHUTZSCHALTER 9M11		999 22 043 1	DROSSELVENTIL 4L4,28D5,	
		17M15,24F6,25D3,26D3,27D3		998 86 346 0	O-RING 40 1H4	999 20 130 4	GEHAEUSE 9M8			28B5,28C5,	
996 07 008 7	SICH.SCHEIBE 5	28J8,28K9,		998 86 500 0	O-RING 3,3 1C4,2C4	999 20 134 8	STROMLAMPPE 9A3,9B3		999 22 045 3	4/ZWEGEVENTIL 11K9,25K8,	
		29L5,29E7,29M6		998 86 522 0	O-RING 27,3 5H6	999 20 154 8	STROMLAMPPE 9A3,9B3			28H8,28J10	
996 07 008 8	SICH.SCHEIBE 5	28J8,28K9,		998 87 502 8	V-RING 18X1,0 1M6	999 20 154 9	GLUEHLAMPE 12V 3W 9A3		999 22 045 4	4/ZWEGEVENTIL 11K9,25K8,	
		29L5,29E7,29M6		998 88 052 0	PASZSCHEIBE 6X10X0,1 14G9	999 20 177 2	GLEICHRICHTERBRUECKE 10B1			26K8,27K8,28J2,28L2,	
996 07 009 8	SICH.SCHEIBE 6	14L7		998 88 061 0	PASZSCHEIBE 12x18x0,1 5C4,5C10	999 21 004 8	GEW.EINSATZ 3H5		999 22 045 5	4/ZWEGEVENTIL 11K9,25K8,	
996 07 010 8	SICH.SCHEIBE 7	1F10,28J9,		998 88 102 0	PASZSCHEIBE 6x10x0,3 14G9	999 21 010 1	SPANNELEMENT 40x45 15B2,			28E4,29F5	
		8L11,8L10,8M11,8L12,11M11,17H16,							999 24 003 9	WINKEL-VERSCHR. R1/4 8M10,11D9,28C4,	
		17H18,29E3,29K9								28H10,28H8	
996 07 011 8	SICH.SCHEIBE 8	14E8							999 24 005 3	SCHLAUCHHUELLE 11A9,	
996 07 012 8	SICH.SCHEIBE 9	16D8,16E3,								11B8,11E7,11E8,11E9,	
										25F6,26F6,27F6	
									999 24 006 4	TSTUECK R1/4 11B8,11D9,	
										11G9	
									999 24 020 9	SCHOTTVERSCHRÄUBUNG 11A9,11E7	

Ersatzteilleiste. Spare parts. Pièces de rechange. Piezas de repuesto.

Teile-Nr.	Benennung	Teile-Nr.	Benennung	Teile-Nr.	Benennung
999 24 025 2	GDE-VERSCHRAUBUNG 11E9, 11J11,11K12,11L9,14K11, 25J1,26J1,27J1,28J1,28L1, 28C4,28D4,28E4,28B5,28O5, 28F5,28G5,28H7,28G10,28L9, 28L11,29D4,29D9				
999 24 025 5	WEV-VERSCHR. 618 4L4, 11B9,11H9,11K11,14D11, 14F11,14G4,14H8,17H14, 25K1,26K1,27K1,28G1,28H3, 28H5,28C3,28J10,28K11, 29A4,29B4,29D4,29B6,29C7, 29C9,29C11,29F9,29G9,29K9				
999 24 025 6	TEV-VERSCHR. 11K9,11L10, 14K11,25L1,26L1,27L1, 28H3,28G2				
999 24 025 8	TES-VERSCHR. 14D11, 14H11,25L1,26L1,27L1, 28H3,28K3,28C5,28H8, 28K10,28M10				
999 24 026 0	TR-VERSCHR. 4/1C11,25J6, 26J6,27J6,28L12,29A8, 29B8,29C8				
999 24 026 2	KR-VERSCHR. 4/1F12,25M1, 26M1,27M1				
999 24 026 9	BLINDSTOPFEN 1J1				
999 24 027 1	DICHRING 12A3,12A9, 13A4,13A9,25K2,25B1, 26K2,26B1,27K2,27B1				
999 24 027 3	SCHW-VERSCHR. 14F11,14H11				
999 24 027 8	T-SCHW-VERSCHR. 25J6, 26J6,27J6				
999 24 030 1	DOPPELNIPPEL R1/4 11C7, 11C8,11C9,11C10, 11D10,11E11,11G9				
999 24 030 2	DOPPELNIPPEL R1/8 14G4, 14H11,25G10,25E1,26E1, 27G10,27E1,28C4,28H8,28J11				
999 24 030 4	REDUZIERNIPPEL R1/4-1/8 11B9,11D10,11H9, 11K12,25J8,26J8, 27J8				
999 24 030 5	T-VERTEILERBLOCK R1/8 14H11,25J3,25E1,26J3, 26E1,27J3,27E1				
999 24 030 6	MUFFE R1/4 25G6,26G6, 27G6				
999 24 033 0	Y VERB.STUECK 1A6,				
999 24 033 4	T-BLOCK 25J8,26H8,27J8				
999 24 034 2	NORMASCHELLE 8M9,11A9, 14L8				
999 24 036 5	SCHWVERSCHRAUBUNG 14L11				
999 24 036 6	T SCHWVERSCHRAUBUNG 14L11				
999 31 073 0	KERBSTIFT 17B5				
999 31 097 0	KERBSTIFT 14B6				
Diskette: 504 Datei: KL.971/972 /Norm					