

INSTRUCTION MANUAL

取扱説明書

完全自動・ゴムつなぎロボット

ELASTIC JOINING ROBOT
AUTOMATIC STAND ALONE SYSTEM

J2800AUM200 シリーズ
SERIES

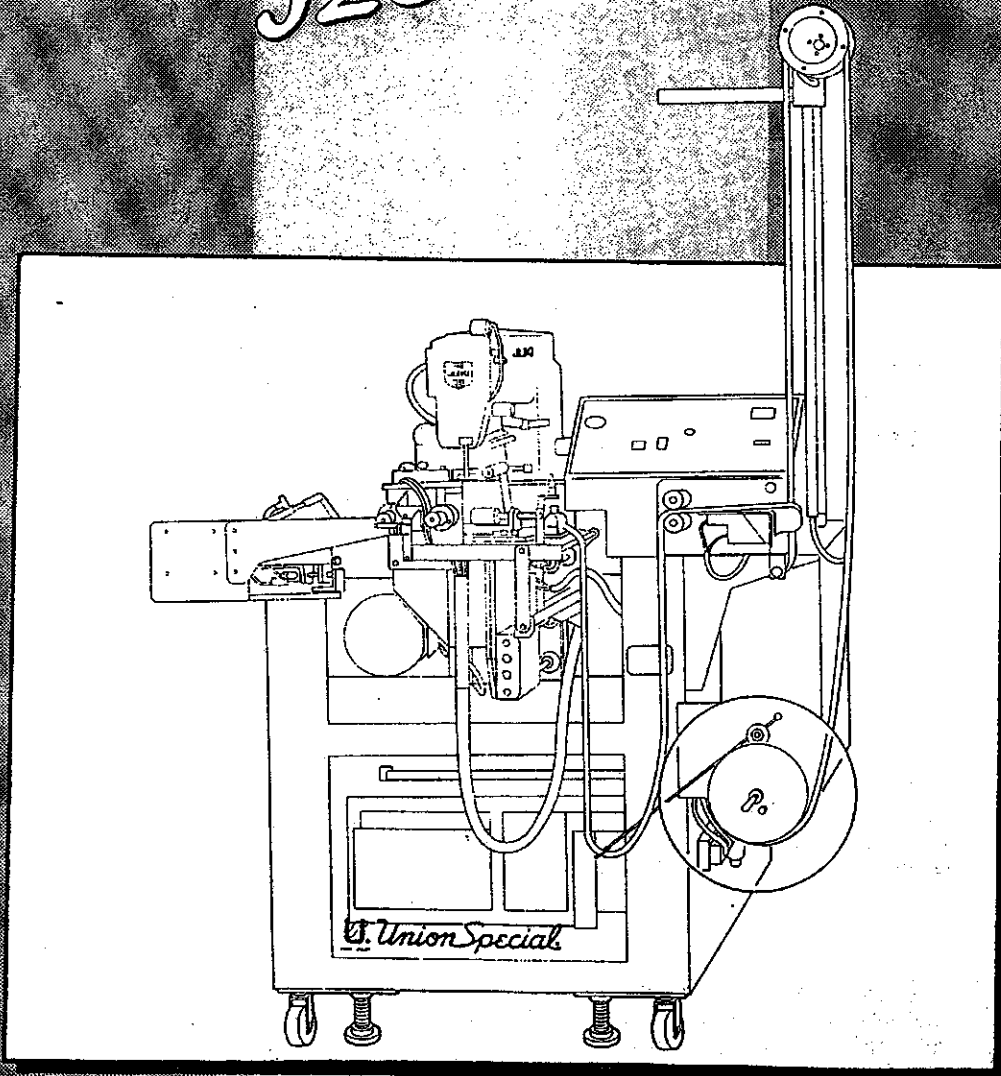

NO. 9420

U. Union Special
Finest Quality

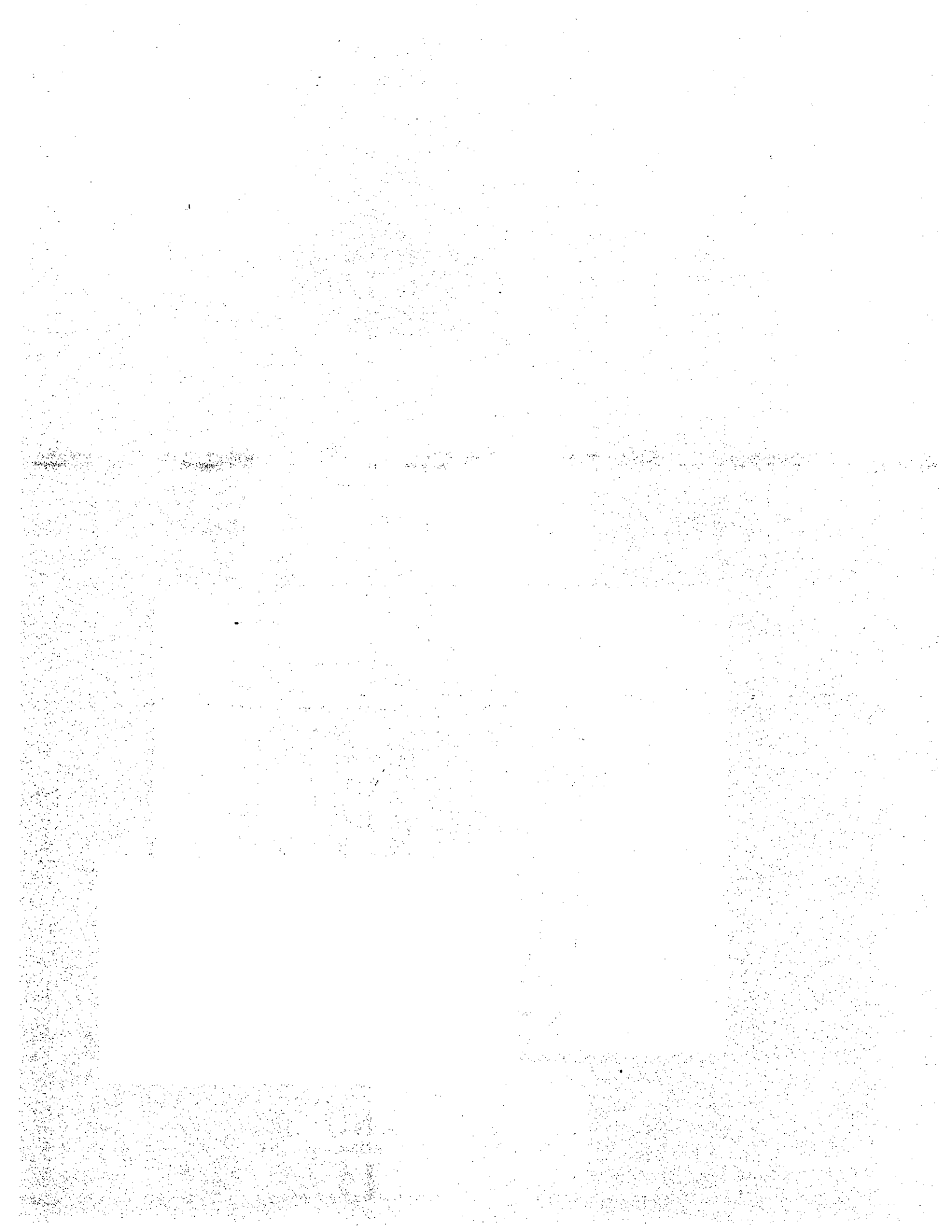

I N D E X

I. GENERAL

1. CONFIGURATION
2. FEATURES

II. INSTALLATION

1. INSTALLING ELASTIC REFORMER
2. INSTALLING THREAD STAND
3. INSTALLING STACKING BAR ASSEMBLY
4. CONNECTING CORD FOR FOOT PEDAL

(OPTIONAL STACKER)

5. INSTALLING CONTROL BOX
6. CONNECTING CORD
7. CONNECTING AIR TUBE

III. OPERATION

1. SETTING UP ELASTIC
2. SUPPLYING "POWER" AND "AIR"
3. SETTING SEWING PATTERN
4. SETTING PRODUCTION LENGTH
5. RESETTING COUNTERS
6. STARTING OPERATION
7. STOPPING OPERATION
8. ENDING OPERATION

IV. MAINTENANCE

1. ADJUSTING FIXED ELASTIC GUIDE POSITION
2. ADJUSTING LOWER POSITION OF ROTARY FINGERS
3. ADJUSTING UPPER POSITION OF ROTARY FINGERS
4. ADJUSTING OVERLAPPING AMOUNT OF ELASTIC
5. ADJUSTING AIR BLOWER ANGLE
6. ADJUSTING AIR BLOWER PRESSURE
7. ADJUSTING UPPER KNIFE ANGLES
8. ADJUSTING LOWER KNIFE ANGLES

V. COMPONENT PARTS

- ① ELASTIC REFORMER
 - ② OPERATION PANEL
 - ④ BUTTING/OVERLAPPING DEVICE
 - ⑤ DRAW-OUT CYLINDER
 - ⑥ ELASTIC FEEDER
 - ⑧ ELASTIC HOLDER
 - ⑨ CONTROL UNIT AND AIR VALVES
- STACKING BAR
THREAD BREAK DETECTOR

I. GENERAL

The "J2800AUM200" series are elastic joining robot for producing butted and overlapped seam equipped with a electronic 1-needle cylinder bed lockstitch bartacker with 32 different preset sizes of sewing patterns. This automatic stand alone system is for producing preclosed elastic rings featuring exact sizing (less than 1mm variation) and requires only 1 minute to changeover into defferent sizes.

I. CONFIGURATION

The following shows the main component units of the "J2800AUM200" series.

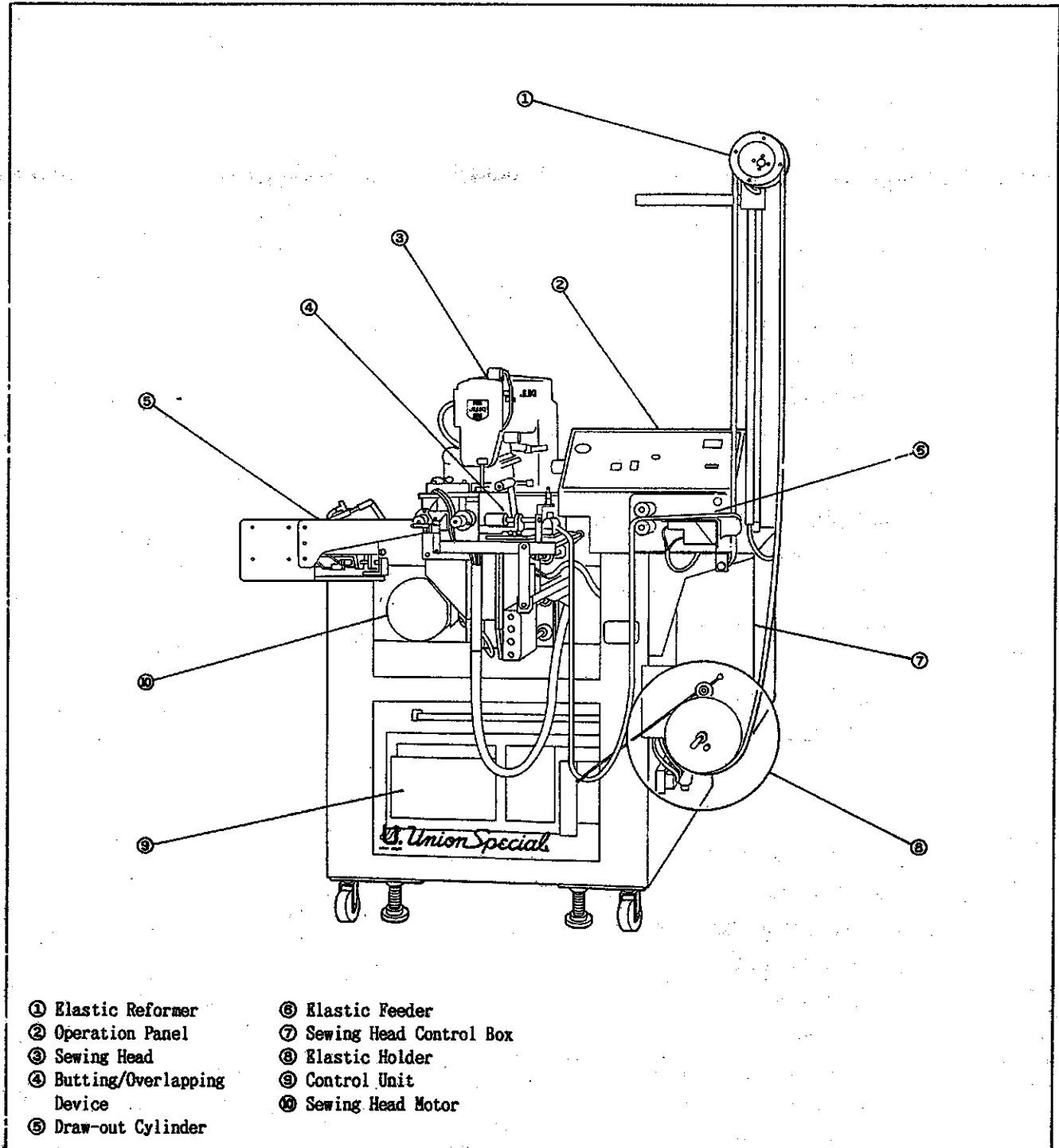

2. FEATURES

- Compact size with built in Elastic Reformer
- 32 sewing patterns are preset and available custom designed patterns & presser fingers for any kinds of draw string elastics.
- High quality thread break detector decreases outbreaking of sub standard article and reduces manually compensated operation.
- High speed metering roller increases productivity.
- Elastic circumference is adjustable from 5 1/2 to 393 in. (140 to 9999 mm).
- List of adjustable elastic width

Machine style	Range of elastic width
J2800AUM200-40	3/32~1 9/16in. (2.5~40mm)
J2800AUM200-50	3/32~2in. (2.5~50mm)
J2800AUM200-50-2R	3/32~3/4in.×2 (2.5~20mm×2)

- Productivity is available from 280 to 333 dz./8 hrs. (3,360 to 4,000 pcs./8 hrs.)
- Available optional stacker 2899S-1 indexes to allow up to 6 groups of up to 60 elastic rings each without operator intervention.

3. SPECIFICATIONS

- ◎ Sewing head : JUKI AMS-205C
Electronic 1-needle cylinderbed lockstitch bartacker
- ◎ Needle : Schmetz 134(R) or Organ DP×5
- ◎ Pattern Memory : P-ROM Max.32 patterns
Available up to 3,000 stitches per pattern
- ◎ Machine Control: Sewing head - Micro computer.
Automated System - Sequencer
- ◎ Dimensions : 37(D) × 43(L) × 59(H) in.
(95(D) × 110(L) × 150(H) cm)
* excluding thread stand and elastic reformer
- ◎ Net weight : 573 lbs. (260 kgs.)
- ◎ Power source : 220V/3ph (standard for U.S.A.)
Available any voltage with optional transformer
- ◎ Air required : 72 PSI (5 kgs./cm²)

II. INSTALLATION

1. INSTALLING ELASTIC REFORMER (Fig.1)

Remove 6 screws ① from the right side of operation panel ② and install Elastic Reformer ③ on operation panel with these screws.

2. INSTALLING THREAD STAND (Fig.2)

Assemble thread stand and put it in the hole of top right corner of table board.

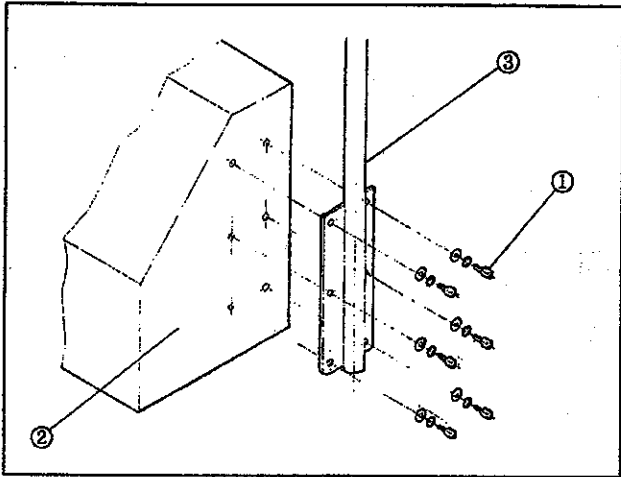

Fig. 1

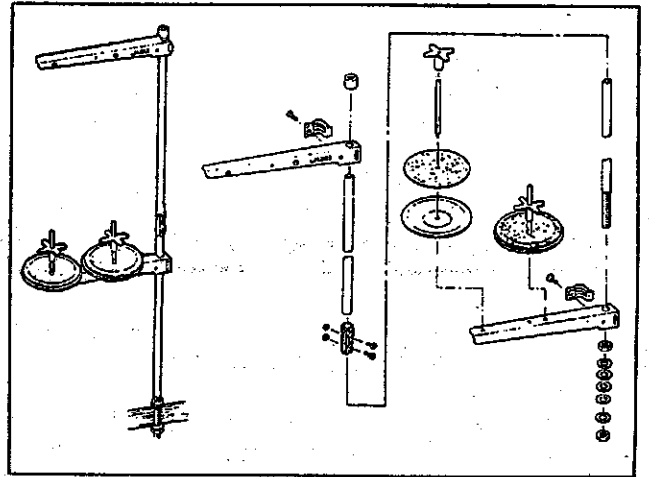

Fig. 2

3. INSTALLING STACKING BAR ASSEMBLY (Fig.3)

Insert stacking bar ① from machine head side underneath guide plate, and joint angle adjusting bar ② with stacking bar with nut ③. Adjust angle of stacking bar when tightening nut not to run against other devices.

4. CONNECTING CORD FOR FOOT PEDAL (Fig.4)

Insert cord ① of foot switch ② into connector ③.

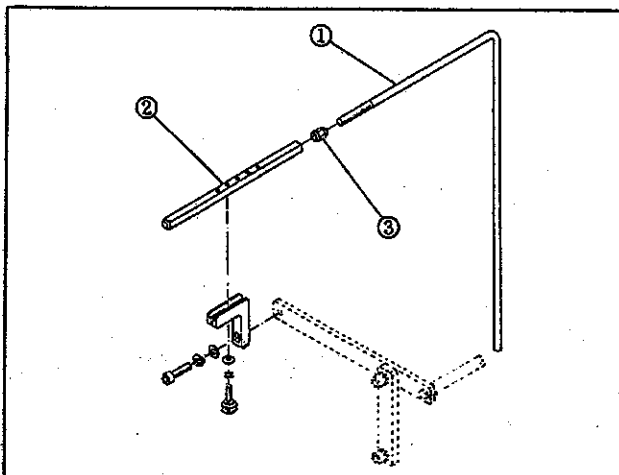

Fig. 3

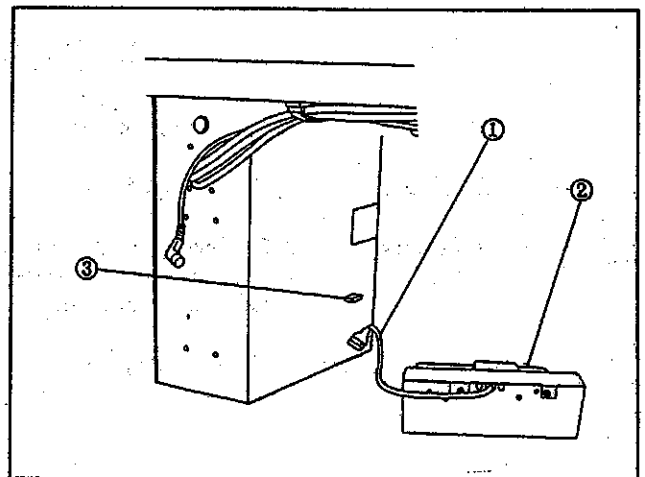

Fig. 4

(OPTIONAL STACKER)

5. INSTALLING CONTROL BOX

Remove 4 screws from the left side of main body and install control box for stacker on the body with these screws.

6. CONNECTING CORD (Fig.5)

Connect 3 lines, BLACK, WHITE and RED from control box of stacker with upper side of switchboard which is located at the front of main body.

<u>Control box side</u>		<u>Switchboard side</u>
Red line (No.4)	→	Terminal No.2
White line (No.5)	→	Terminal No.3
Black line (No.532)	→	Terminal No.Y10

7. CONNECTING AIR TUBE (Fig.6)

Connect air tube comes from main body into middle connector (IN side) of solenoid valve located at the bottom of stacker control box.

Connect 2 air tubes come from stacker into solenoid valve (OUT side).

<u>Stacker side</u>		<u>Control box side</u>
Upper connector	→	Connector B
Lower connector	→	Connector A

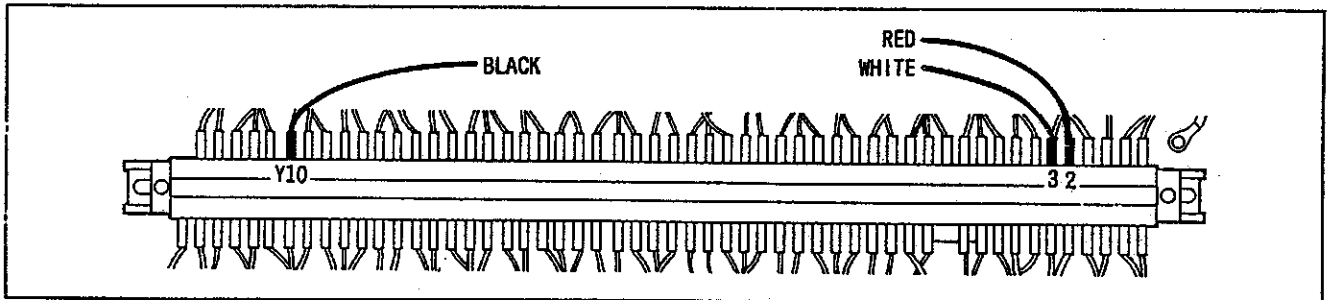

Fig. 5

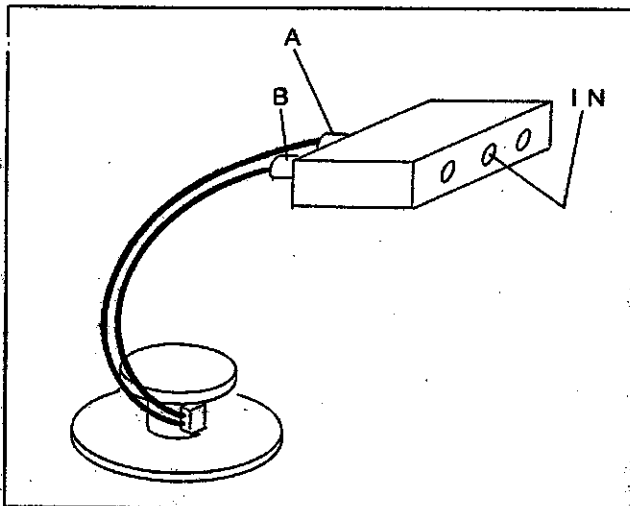

Fig. 6

III. OPERATION

1. SETTING UP ELASTIC

Set up elastic tape through REFORMER (Fig.1) → ELASTIC FEEDER (Fig.2) → GUIDE WIRE → STAGE PLATE (Fig.3) in order.

Adjust elastic guides of aboves accordingly.

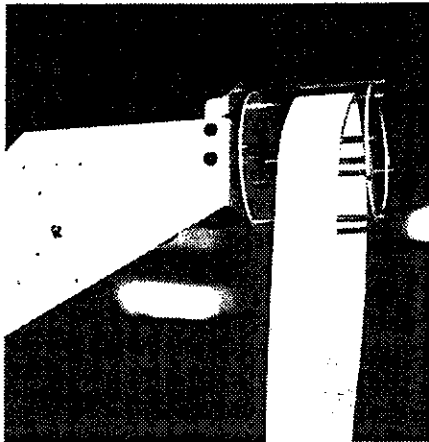

Fig. 1



Fig. 2



Fig. 3

2. SUPPLING "POWER" AND "AIR"

Turn on "POWER" and "AIR" switches located on operation panel.

Make sure pilot lamp for "POWER" turns on, and air indicator points 5kg./cm².

3. SETTING SEWING PATTERN

Select sewing pattern and set pattern number on operation panel of JUKI control box.

(Refer JUKI instruction manual No.29056306, p.14-15)

4. SETTING PRODUCTION LENGTH

Set required length on "LOOP LENGTH" counter located on operation panel by pressing "+" or "-" key.

5. RESETTING COUNTERS

Reset "SET COUNTER" and "TOTAL COUNTER" located on control panel as occasion demands.

6. STARTING OPERATION

After making sure no error lamp turns on, press "START" button located on operation panel once.

Machine starts operation and stops at butting/overlapping position.

Press "START" button again so unit starts continuous operation.

7. STOPPING OPERATION

Press "RESET" button located on operation panel to stop operation.

To stop machine at its best position for re-starting, press this button when machine is under sewing.

The following 2 switches located on operation panel are also used to stop operation.

① "MANUAL STOP" switch

Turn on this switch at any time. Machine stops at butting/overlapping position. For releasing, turn off this switch and press "START" button.

② "STOP SEW" switch

Turn on this switch at any time. Machine stops at sewing start position. For releasing, turn off this switch.

8. ENDING OPERATION

Stop machine by pressing "RESET" button so machine stops at the start position.

Turn off "POWER" and "AIR" switches.

IV. MAINTENANCE

1. ADJUSTING FIXED ELASTIC GUIDE POSITION (Fig.1)

Loosen screw and adjust fixed elastic guide position so elastic edge is located at 5 mm inside from tip of lower knife.

2. ADJUSTING LOWER POSITION OF ROTARY FINGERS

Turn off air switch, and place right and left rotary fingers at the bottom of their stroke with opening their fingers.

Move draw-out cylinder to the right by hand with opening its clamp fingers, and make sure upper clamp finger passes through movable and fixed rotary fingers without touching. (Fig.2)

Move draw-out cylinder to the left by hand with holding elastic tape, and make sure closed clamp fingers pass through movable and fixed rotary fingers without touching. (Fig.3)

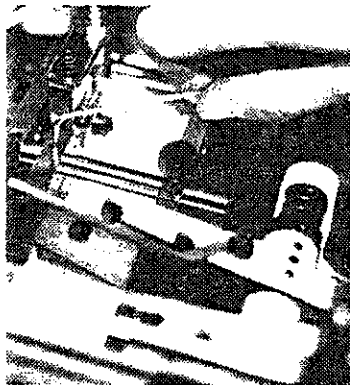

Fig. 1

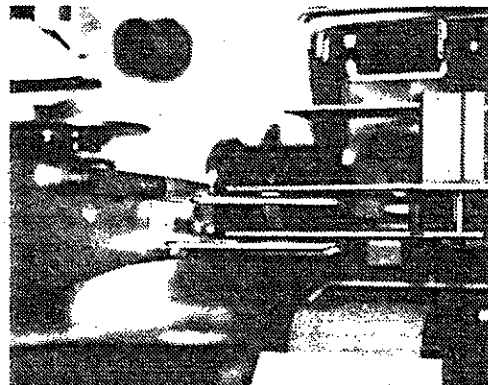

Fig. 2



Fig. 3

For adjusting lower position of rotary fingers, remove rotary cylinder cover by loosening 3 screws (Fig.4), and loosen lower stopper screw to make a correct clearance. (Fig.5)

3. ADJUSTING UPPER POSITION OF ROTARY FINGERS

Turn off air switch, and place right and left rotary fingers at the top of their stroke with opening their fingers. Make sure both right and left fingers get on guide plate with keeping parallel against guide plate.

For adjusting upper position of rotary fingers, remove rotary cylinder cover by loosening 3 screws, and loosen upper stopper screw to make a correct angle. (Fig.6)

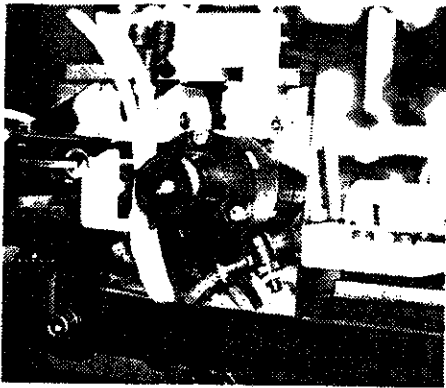

Fig. 4

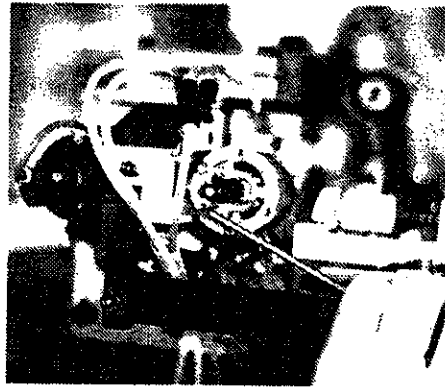

Fig. 5

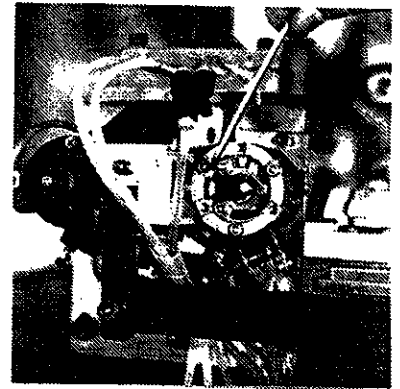

Fig. 6

4. ADJUSTING OVERLAPPING AMOUNT OF ELASTIC (Fig.7) (BUTTING \longleftrightarrow OVERLAPPING)

Loosen screws for both right and left rotary cylinder bases so cylinder bases move freely.

Adjust each base position to get a correct overlapping amount or butting.

In case of butting, make sure elastic butts at the center of guide plate.

5. ADJUSTING AIR BLOWER ANGLE

Each 2 air blower pipes are fixed by each right and left screws.

loosen each screws and adjust blower pipe angles so each pipe blows air to press elastic when overlapped/butted on guide plate.

As regards left end pipe, it blows air when elastic is drawn out. (Fig.8)

For checking air blowing, turn on air switch and rotate rotary cylinders to their upper positions by hand. (Fig.9)

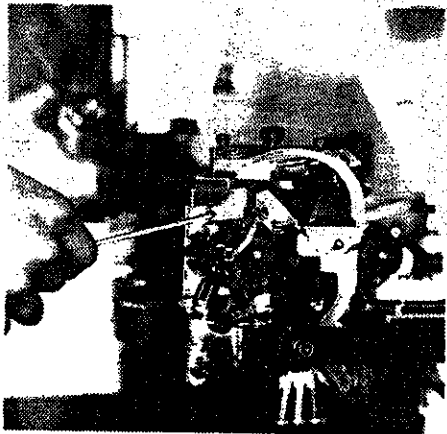

Fig. 7

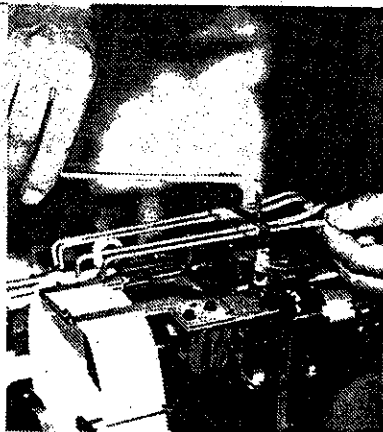

Fig. 8

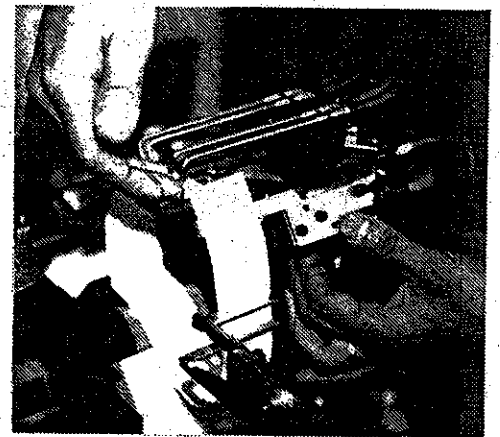

Fig. 9

6. ADJUSTING AIR BLOWER PRESSURE (Fig.10)

Air blower pressure is adjustable by 3 pcs of speed controllers located under air blower pipes.

Left controller controls left end blower, mid one controls 2nd blower from the left, and right one controls right 2 blowers.

7. ADJUSTING UPPER KNIFE ANGLES

Adjust upper knife angle so clamp fingers of draw-out cylinder pass through upper and lower knives when they hold elastic and return to the left.

Upper knife angle should be also adjusted so tip of upper knife bites more than half of lower knife thickness.

For adjusting upper knife angle, loosen 2 stopper screws located on the top of upper knife holder and 2 screws fixing upper knife.

8. ADJUSTING LOWER KNIFE ANGLES

Lower knife angle should be adjusted not to exist any binds between upper and lower knives when they bite.

Turn off air switch and make sure above by cutting elastic manually. (Fig.11)

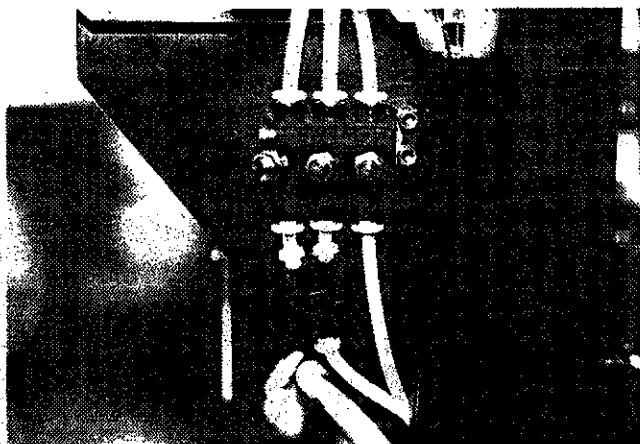

Fig. 10

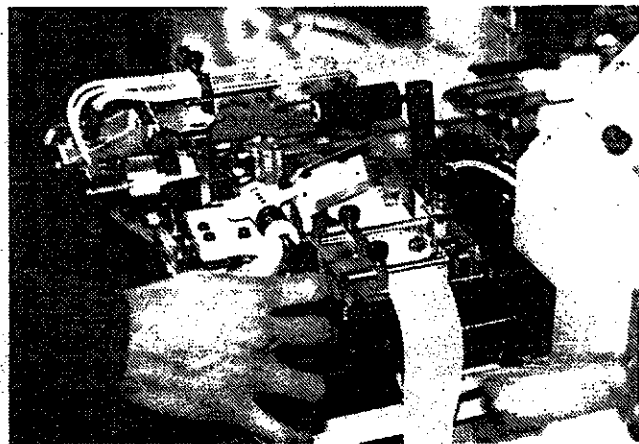
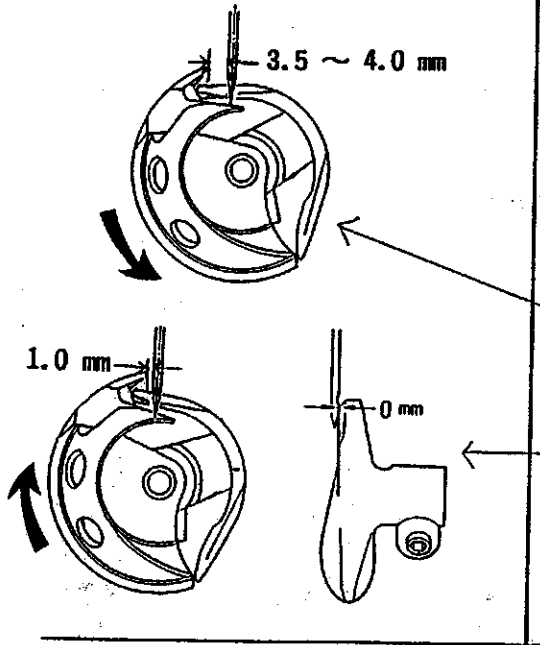
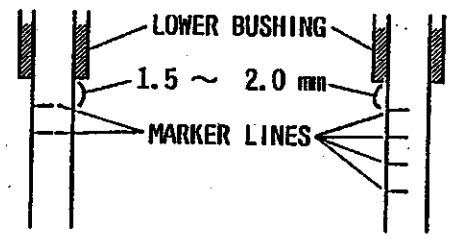

Fig. 11

THREAD BREAKAGE DURING SEWING OPERATION

CAUSES	CORRECTIVE MEASURES
<p>1. INCORRECT TIMING ADJUSTING</p> 	<p>① NEEDLE BAR SHOULD BE SET 1.5 ~ 2.0 mm LOWER THAN NORMAL ADJUSTING OF JUKI INSTRUCTION. (REFER "JUKI" INSTRUCTION MANUAL - P.27)</p> <p>MAKE NEEDLE BAR DOWN TO THE LOWEST OF ITS STROKE. LOOSEN SET SCREW, AND ADJUST NEEDLE BAR SO THAT THE DISTANCE BETWEEN BOTTOM OF LOWER BUSHING AND TOP LINE (OR UPPER LINE) OF NEEDLE BAR AS SHOWING BELOW.</p>  <p>② SET SHUTTLE RACE POSITION SO THAT THE DISTANCE BETWEEN SHUTTLE POINT AND LEFT SURFACE OF NEEDLE IS 3.5 ~ 4.0 mm WHEN SHUTTLE RACE TURNS TO ITS FURTHEST POSITION FROM NEEDLE.</p> <p>③ SET SHUTTLE DRIVER POSITION SO THAT THE CLEARANCE BETWEEN SHUTTLE DRIVER AND NEEDLE IS 0.0 mm WHEN THE DISTANCE BETWEEN SHUTTLE POINT AND LEFT SURFACE OF NEEDLE IS 1.0 mm.</p> <p>④ OTHER ADJUSTINGS SHOULD BE DONE WITH FOLLOWING "JUKI" INSTRUCTION MANUAL.</p>
<p>2. NEEDLE DESCENDS TO OUTSIDE OF MATERIAL DURING SEWING.</p>	<p>① SET CORRECT SEWING PATTERN AND CORRECT SCALE.</p>
<p>3. NEEDLE DOES NOT MEET WITH GARMENT.</p>	<p>① CHANGE NEEDLE TO THICKER ONE WHEN THICKER GARMENT IS SEWN. (NEEDLE SHOULD BE CHANGED DEPENDS ON GARMENT)</p>
<p>4. CHECK CAREFULLY IF THERE ARE FLAWS OR CRACKS ON SHUTTLE POINT</p>	<p>① GRIND OR REPLACE PARTS.</p>
<p>5. CHECK CAREFULLY IF THERE ARE FLAWS OR CRACKS ON NEEDLE HOLE OF THROAT PLATE.</p>	<p>① GRIND OR REPLACE PARTS.</p>
<p>6. CHECK CAREFULLY IF THERE REMAINS BROKEN NEEDLE PIECE BECAUSE IT SOMETIMES STICKS TO THROAT PLATE WHEN NEEDLE IS BROKEN.</p>	<p>① GRIND OR REPLACE PARTS.</p>
<p>7. CHECK CAREFULLY IF THERE ARE FLAWS OR CRACKS INSIDE OF PRESSER FINGERS.</p>	<p>① GRIND OR REPLACE PARTS.</p>

V. COMPONENT PARTS (REFER P.1, CONFIGURATION)

① Elastic Reformer

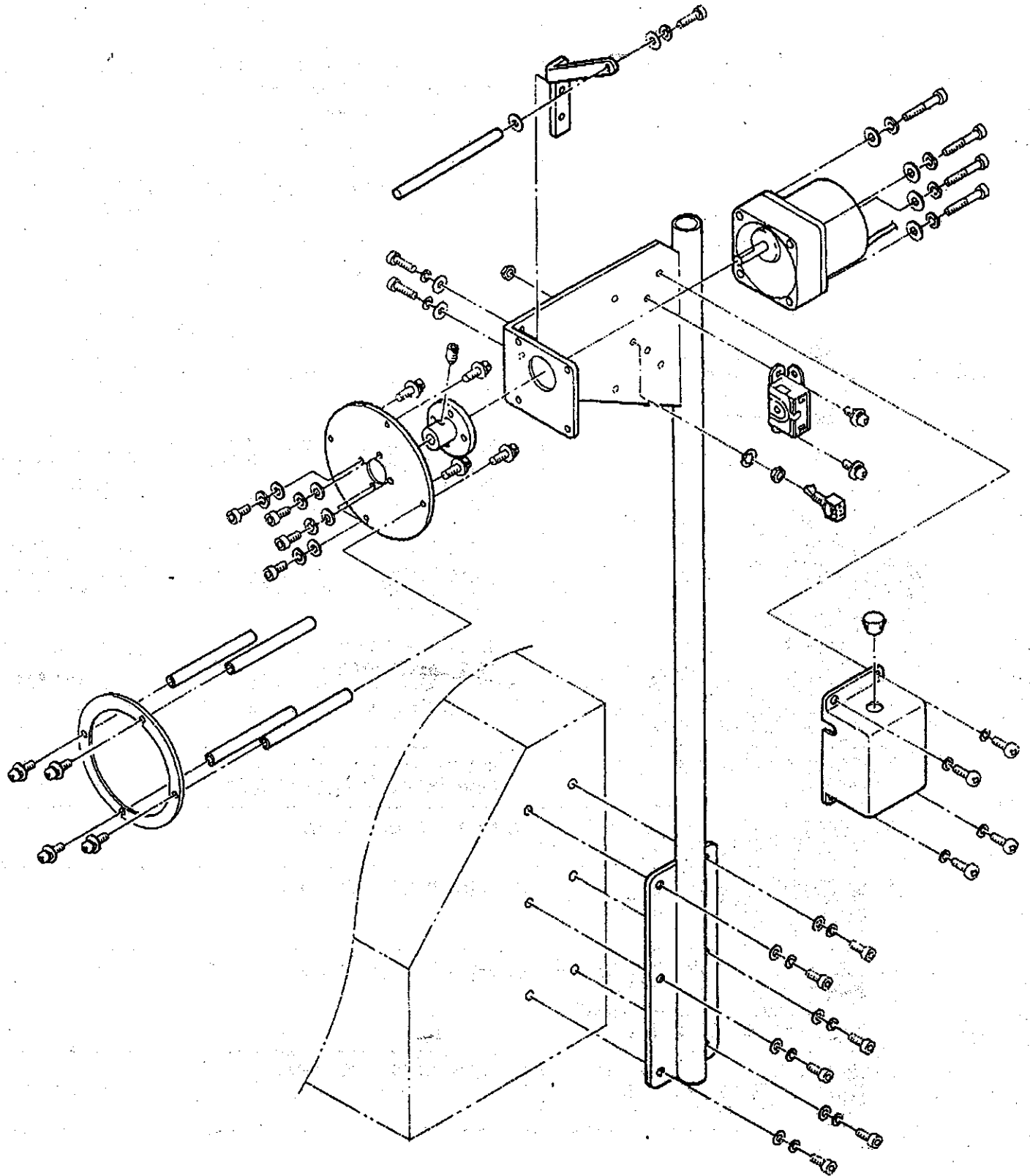

② Operation Panel

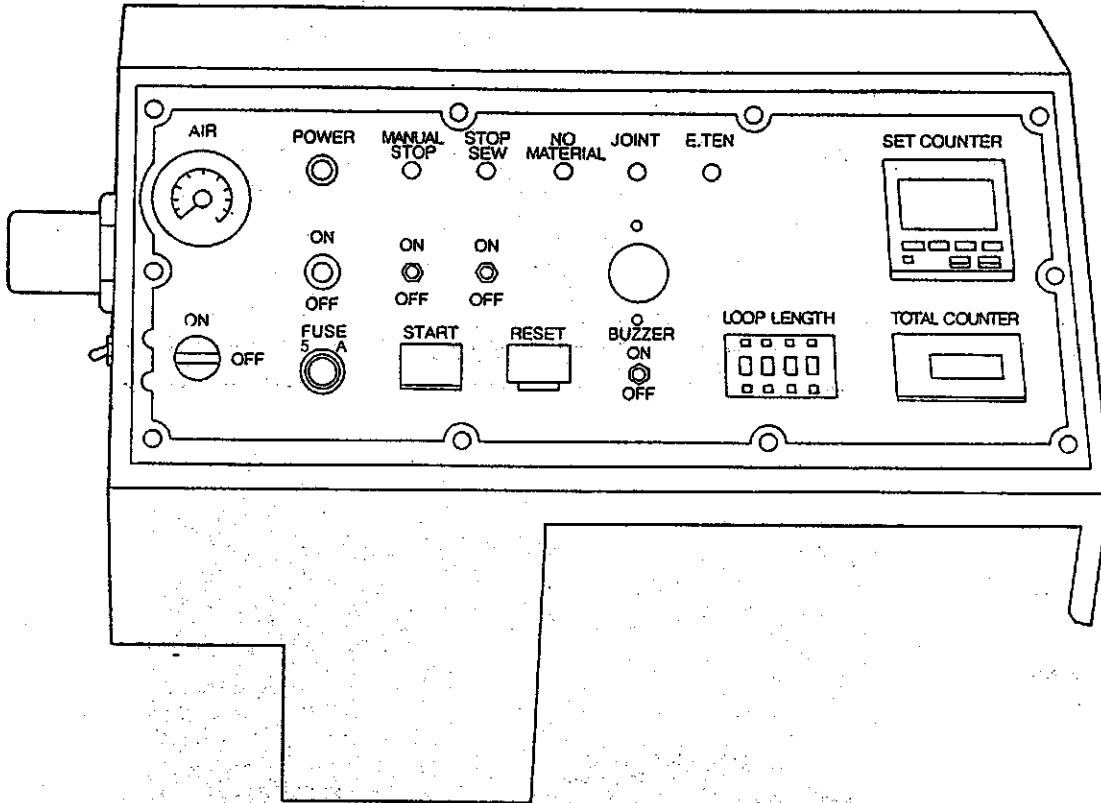

④ Butting/Overlapping Device - 1

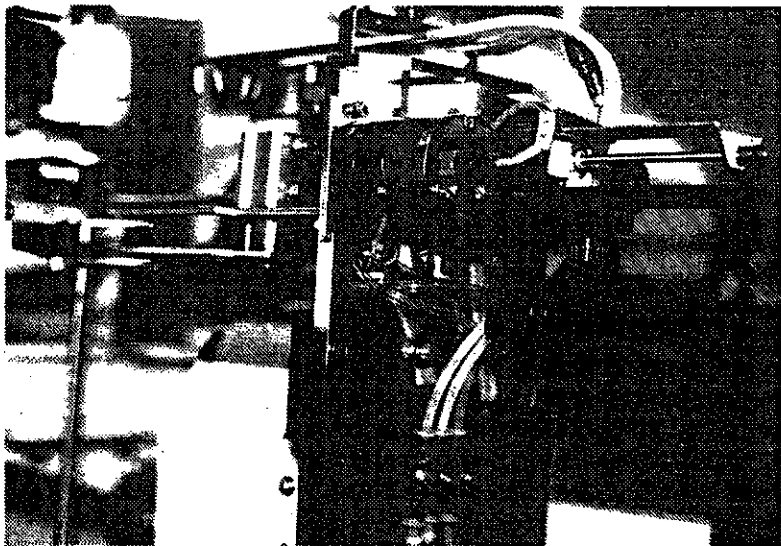
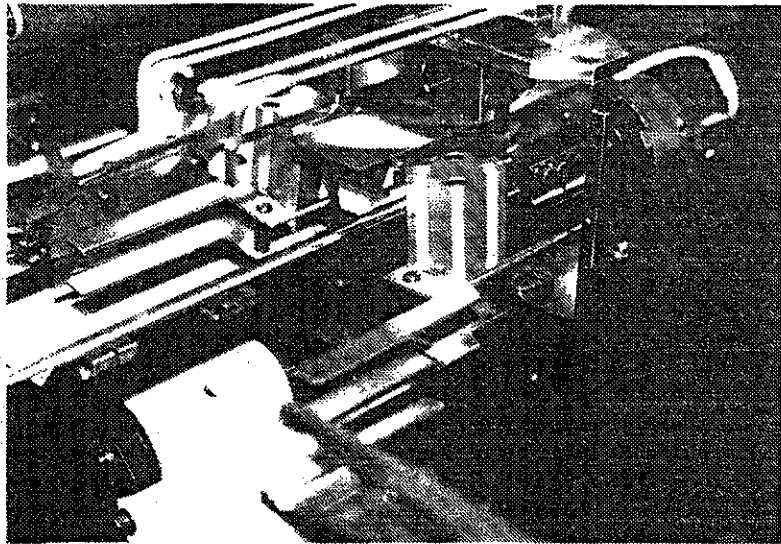
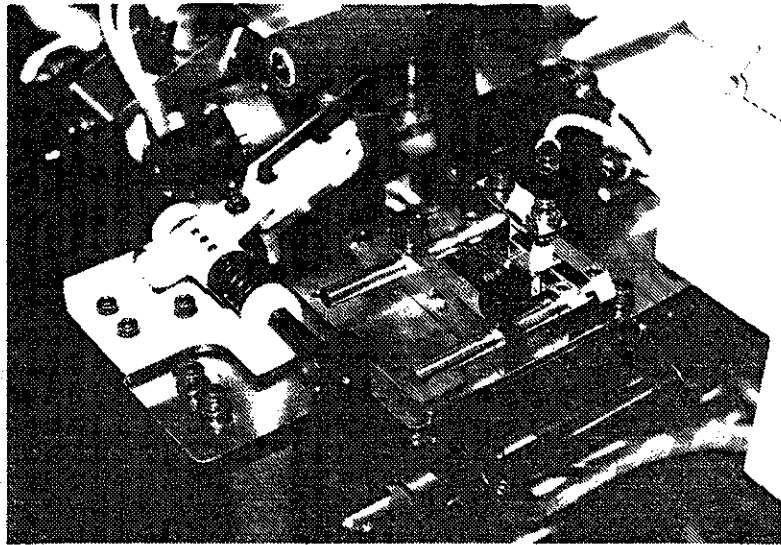

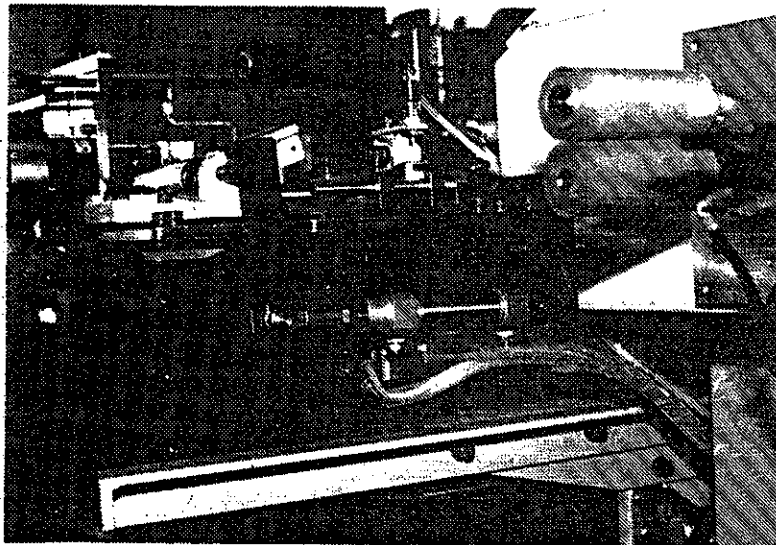
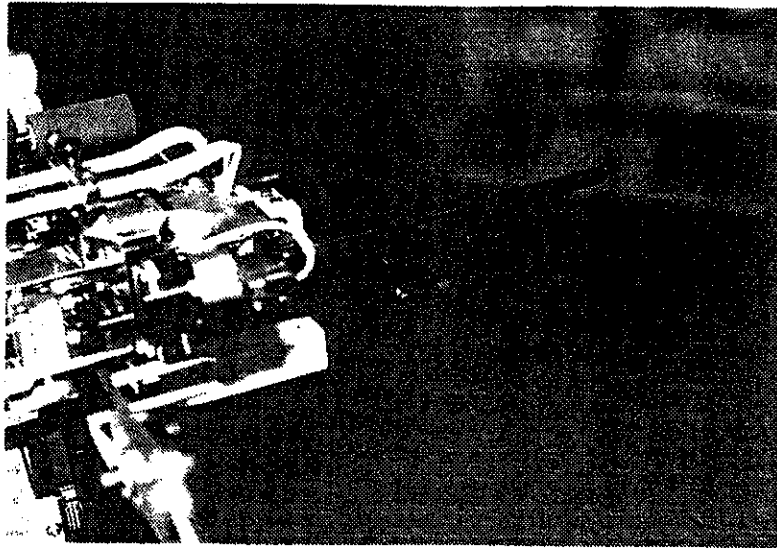

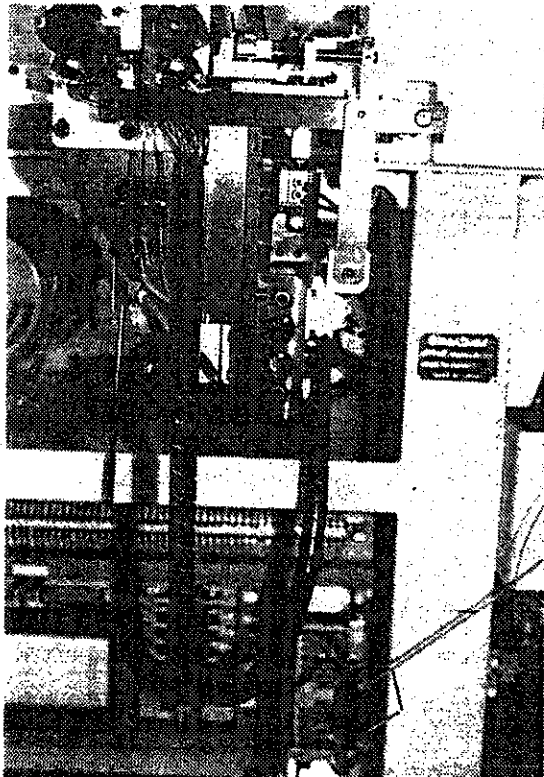
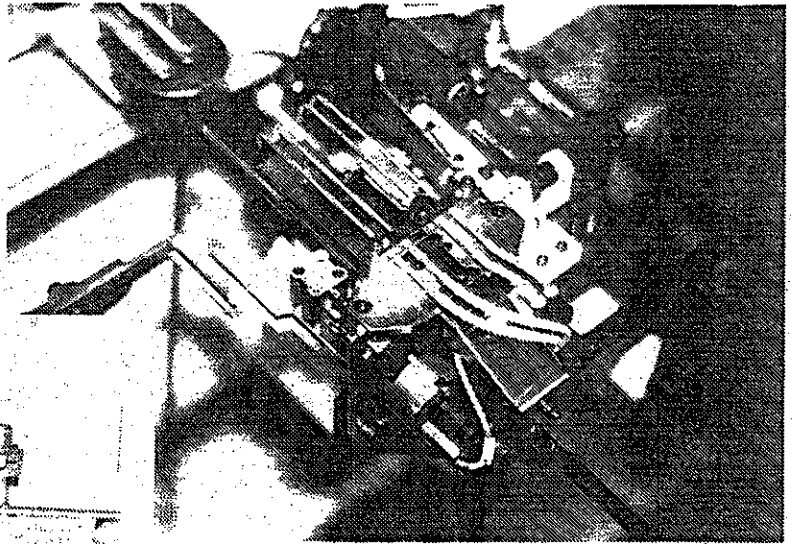
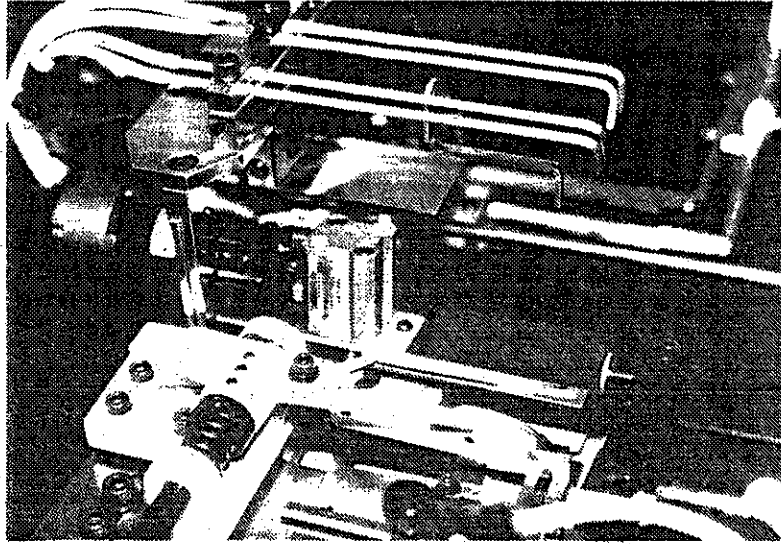

④ Butting/Overlapping Device - 4

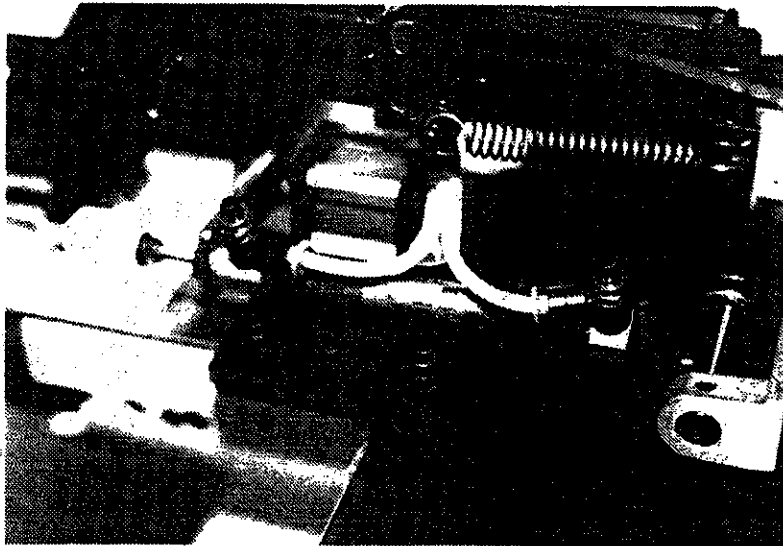
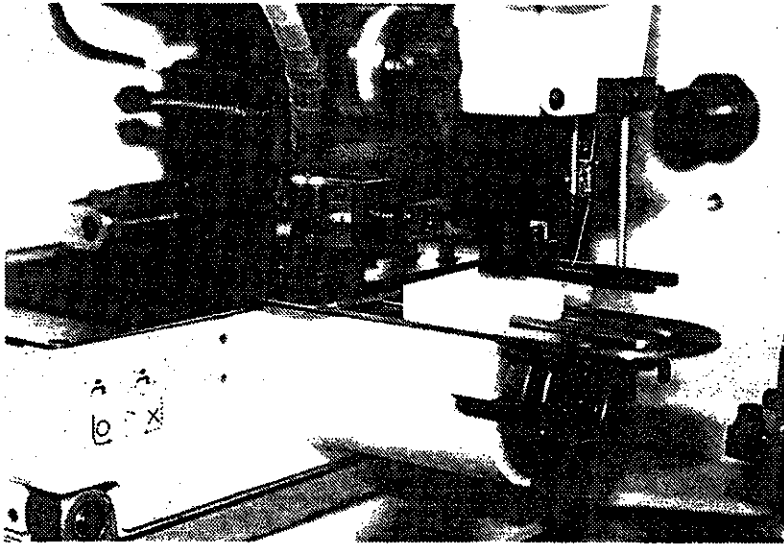
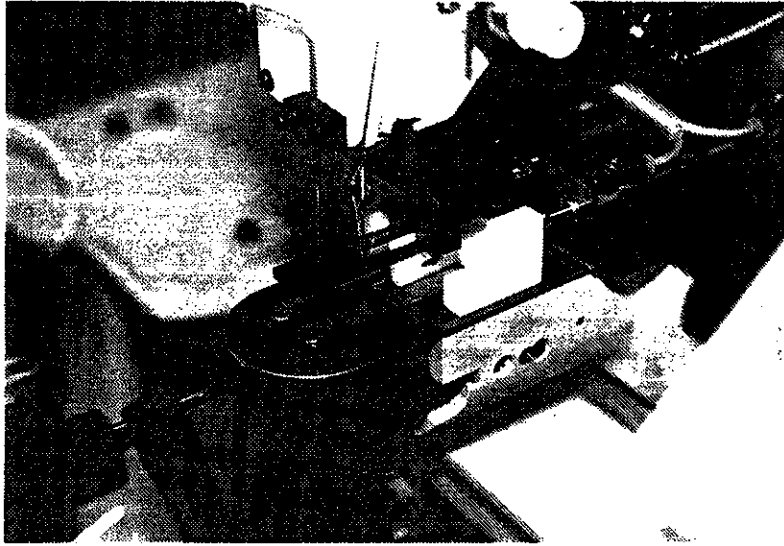

⑤ Draw-out Cylinder

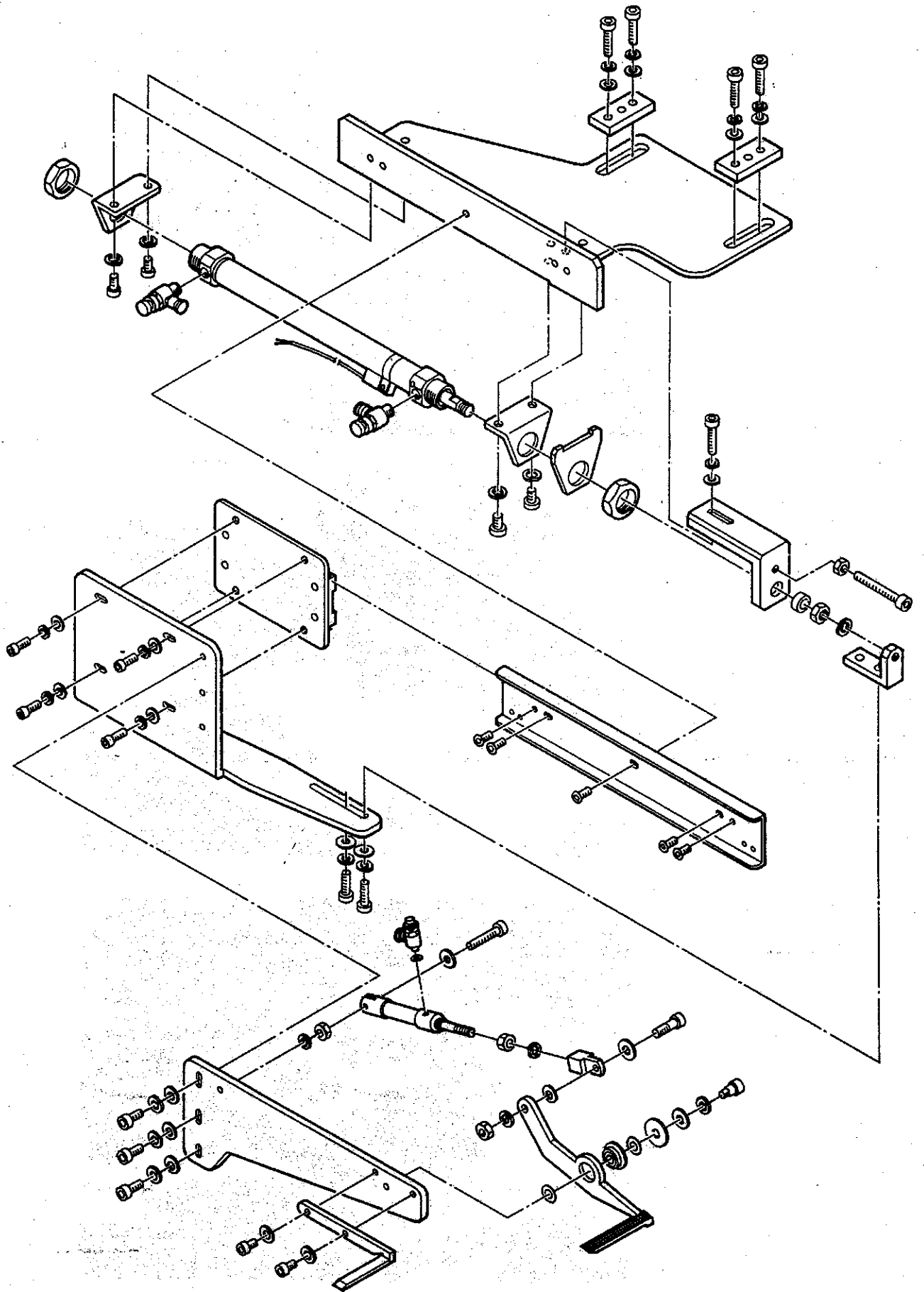

⑥ Elastic Feeder

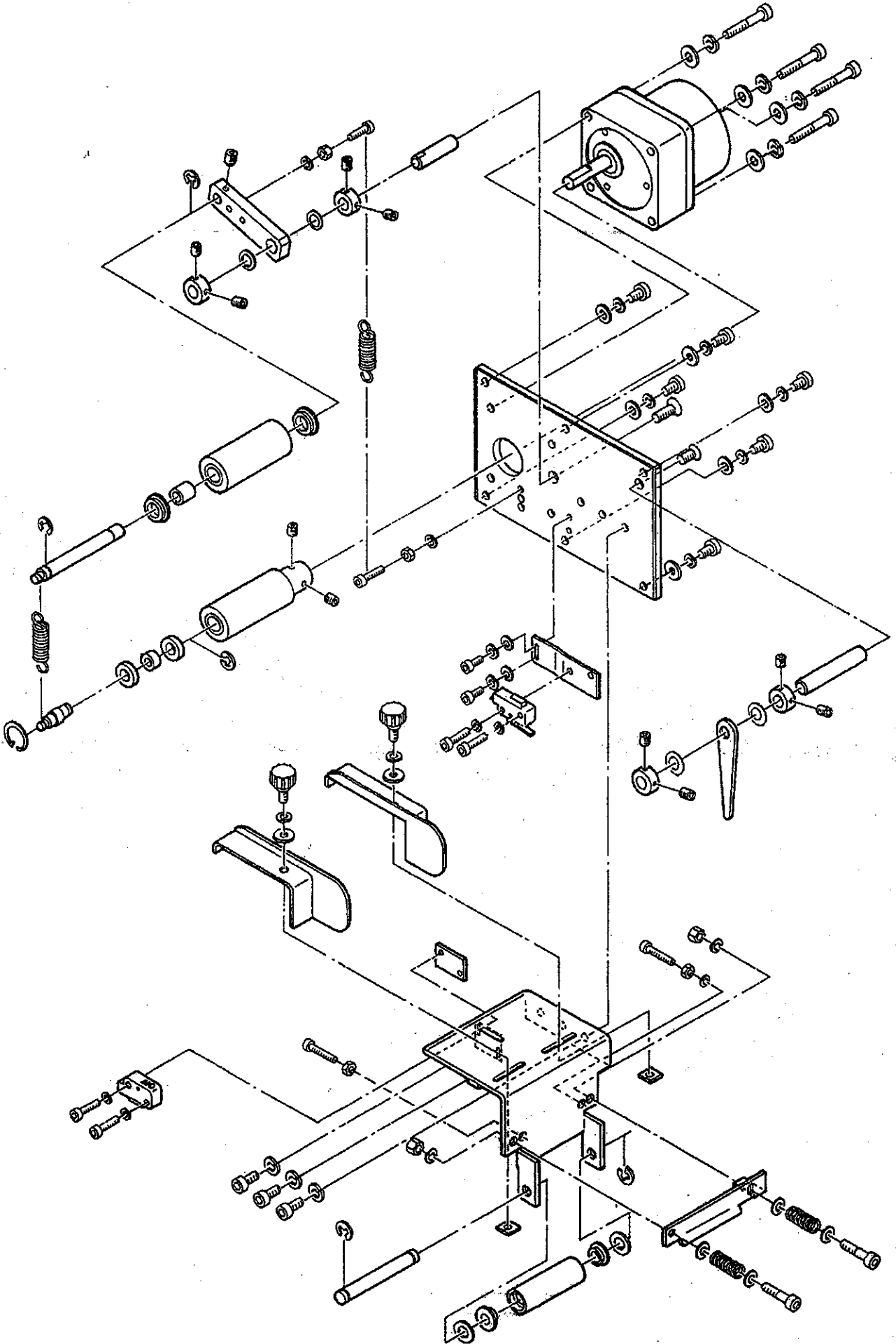

⑧ Elastic Holder

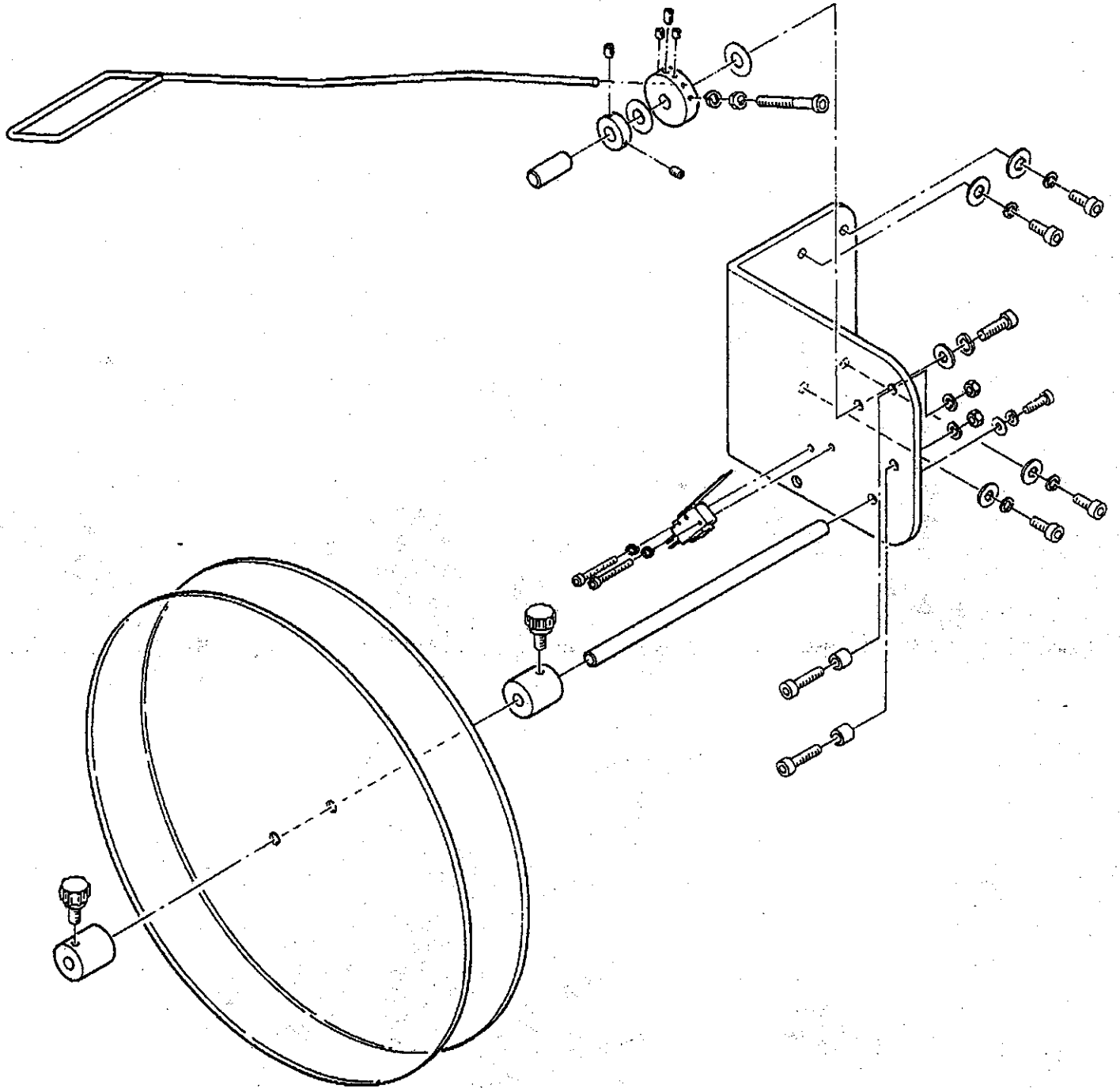

⑨ Control Unit and Air Valves

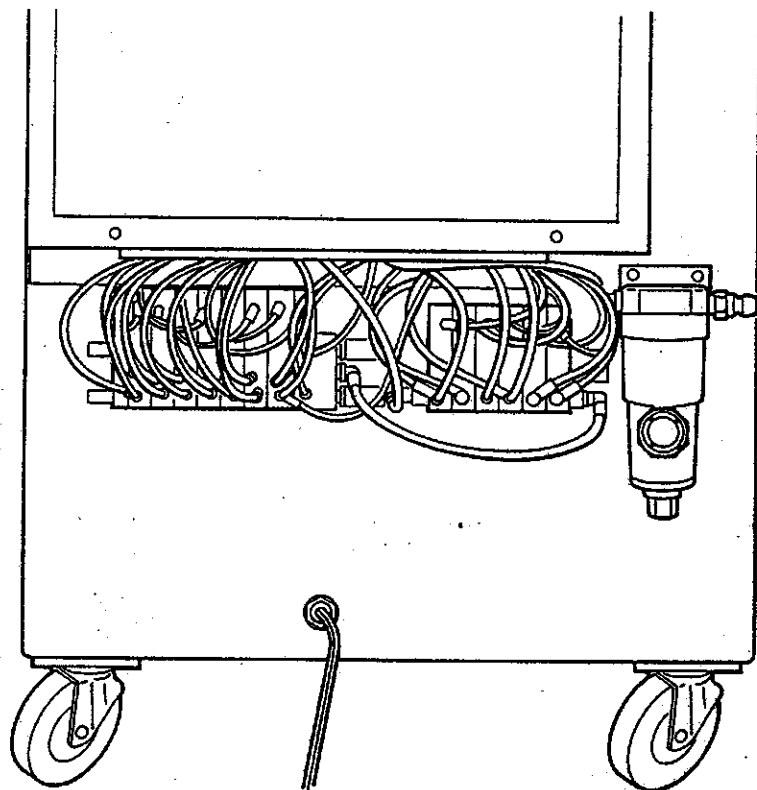
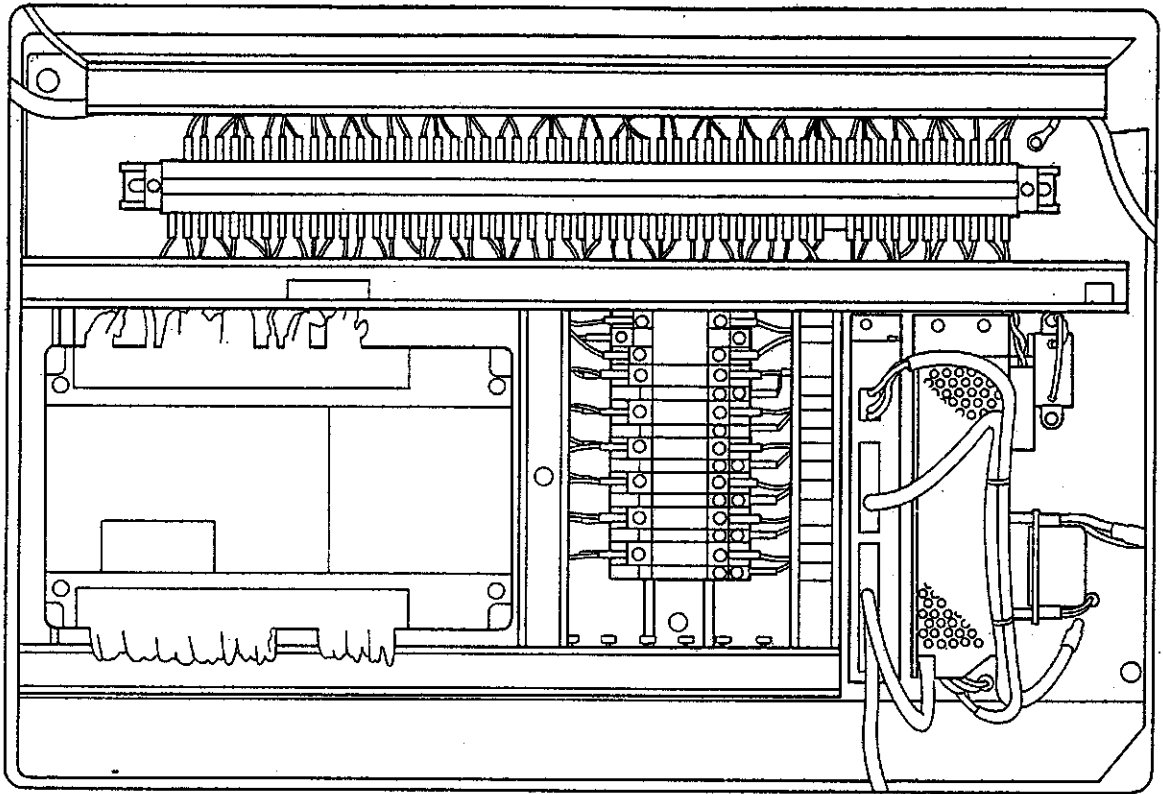

Stacking Bar

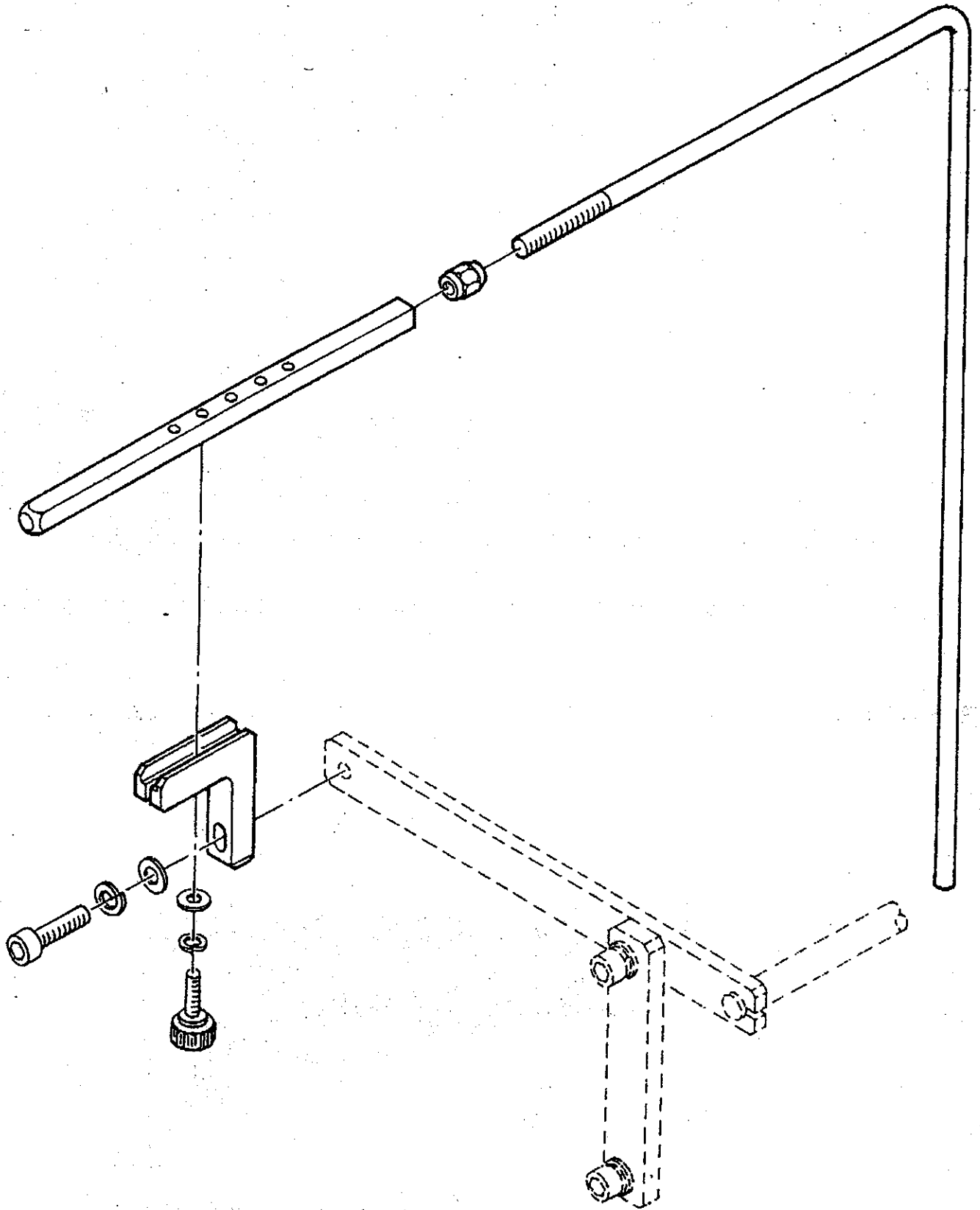

Thread Break Detector

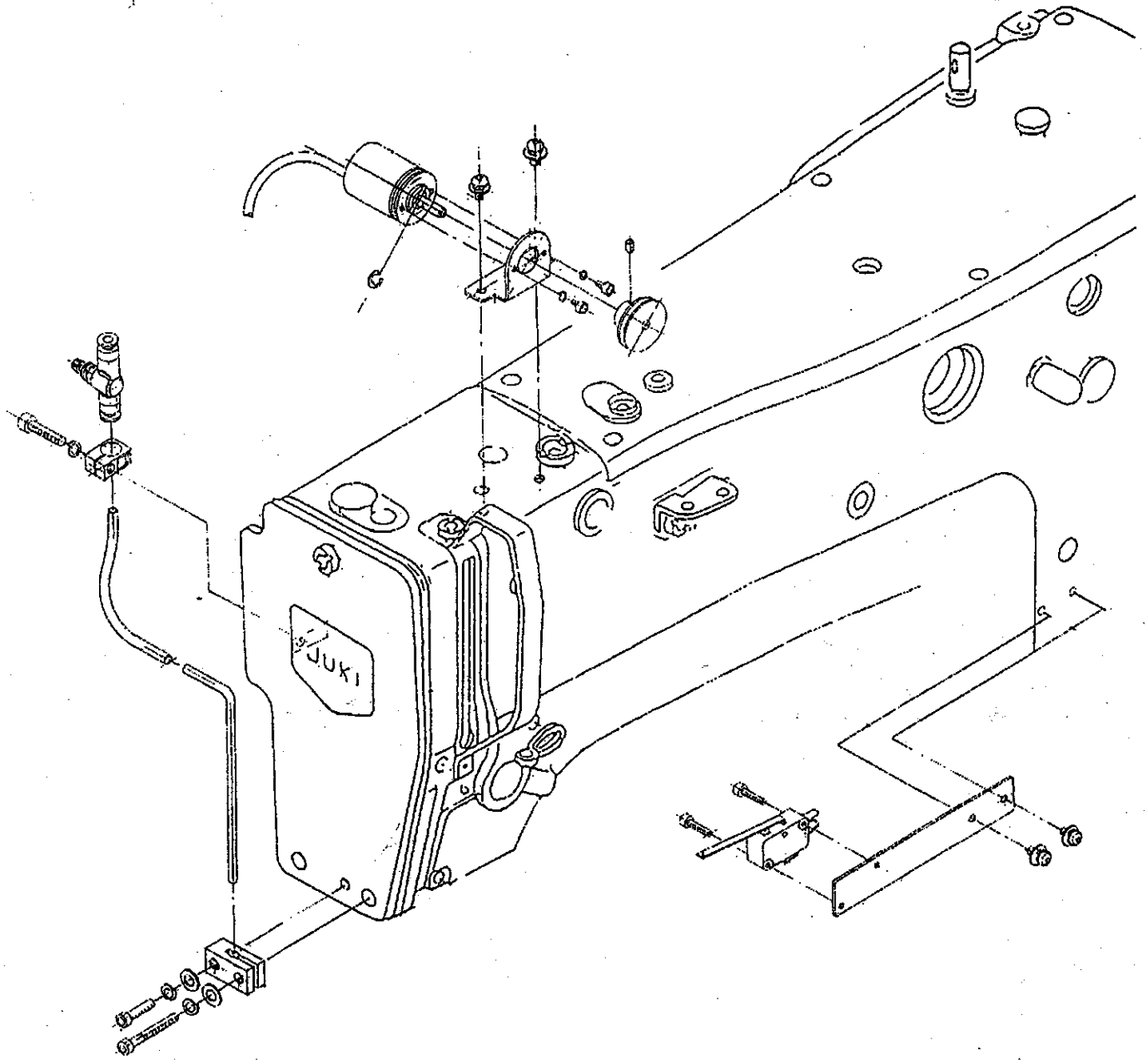

Work Clamp Feet

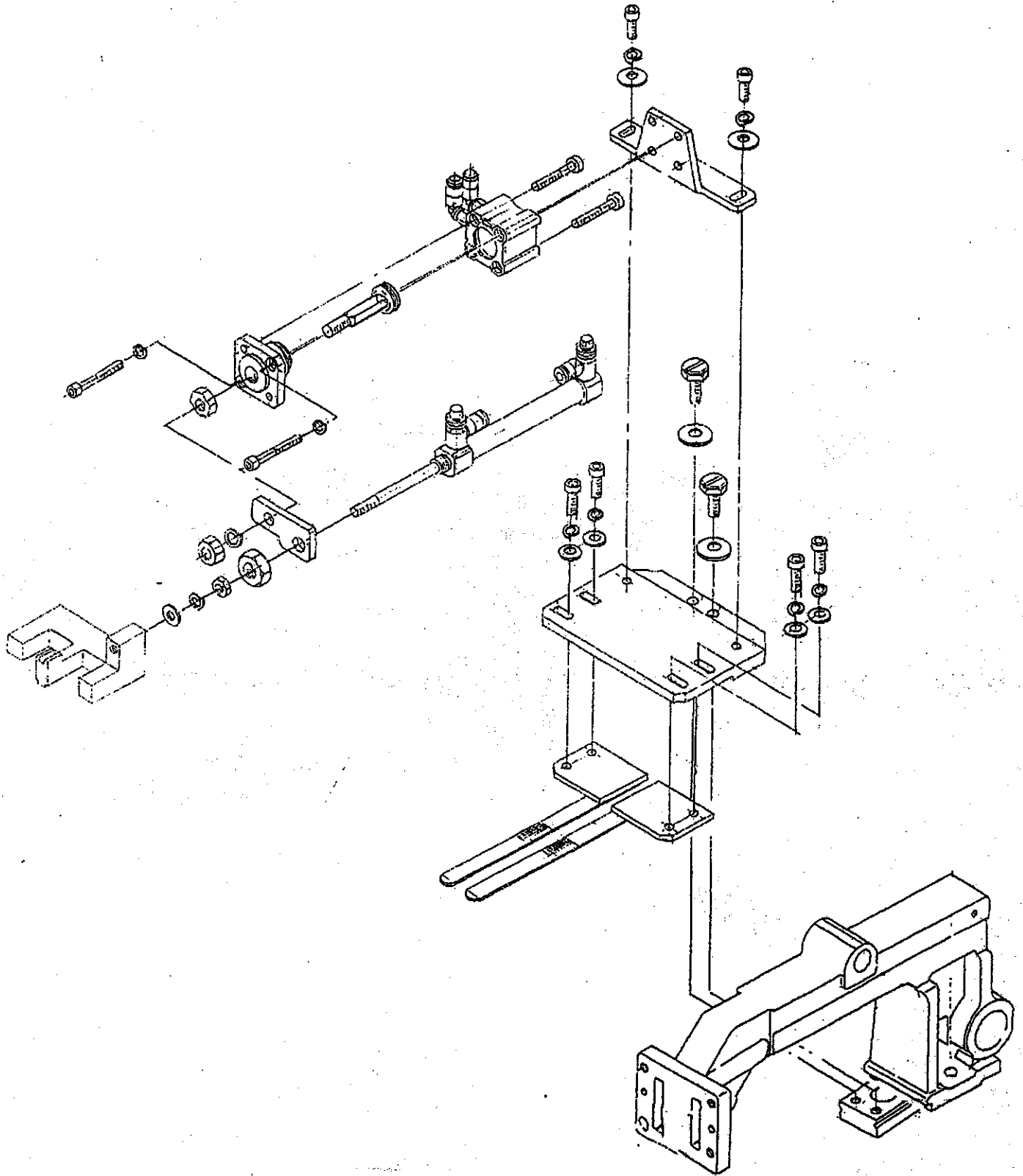

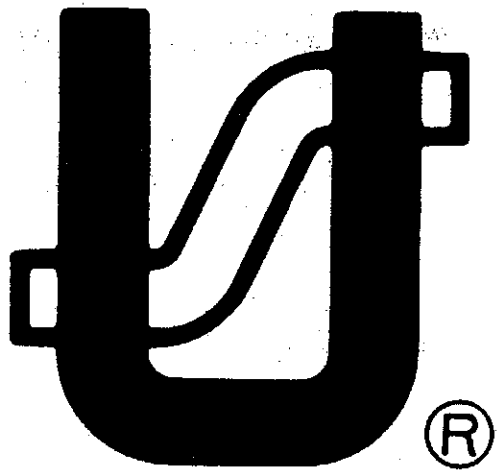

FINEST QUALITY