

5489

INSTRUCTION MANUAL

This instruction manual applies to machines
from the following serial numbers onwards:

2 768 477 →

The reprinting, copying or translation of PFAFF Instruction Manuals, whether in whole or in part, is only permitted with our previous authorization and with written reference to the source.

**PFAFF Industriesysteme
und Maschinen AG**

Hans-Geiger-Str. 12 - IG Nord
D-67661 Kaiserslautern

Contents		Page
1	Safety	5
1.01	Regulations	5
1.02	General notes on safety.....	5
1.03	Safety symbols	6
1.04	Important notes for the user.....	6
1.05	Notes for operating and technical staff	7
1.05.01	Operating staff	7
1.05.02	Technical staff	7
1.06	Danger warnings.....	8
2	Proper use.....	9
3	Specifications	10
3.01	PFAFF 5489.....	10
3.02	Models and work aids	10
4	Disposal of Machine	11
5	Transportation, packing and storage.....	12
5.01	Transportation to customer's premises	12
5.02	Transportation inside the customer's premises	12
5.03	Disposal of packing materials	12
5.04	Storage	12
6	Explanation of symbols.....	13
7	Controls	14
7.01	Main switch	14
7.02	Pedal	14
7.03	Keys on the machine head.....	15
7.04	Raising the presser foot.....	15
7.05	Thread tension release lever	16
7.06	Reverse feed lever	16
7.07	Stitch length and Differential feed levers	17
7.08	Control panel.....	17
7.09	Puller (-948/26)	17
8	Installation and commissioning	18
8.01	Installation.....	18
8.01.01	Adjusting the table-top height.....	18
8.01.02	Assembling the motor P40 ED	19
8.01.03	Tightening the V-belt	19
8.01.04	Mounting the bottom V-belt guard	20

	Contents	Page
	Contents	Page
8.01.05	Fitting the upper belt guard.....	20
8.01.06	Fitting the synchronizer	21
8.01.07	Fitting the reel stand	21
8.02	Connecting the plug-in connections and earth cables	22
8.03	Commissioning	23
8.04	Switching the machine on/off	23
8.05	Basic position of the machine drive unit P40ED	24
9	Setting up	25
9.01	Inserting the needle	25
9.02	Threading the needle thread and regulating its tension	26
9.03	Threading the looper thread and regulating its tension	27
9.04	Adjusting the differential feed	28
10	Care and maintenance.....	29
10.01	Servicing and maintenance intervals	29
10.02	Cleaning the machine	29
10.03	Lubricating	30
10.04	Checking/regulating the air pressure	31
10.05	Emptying/cleaning the water bowl of the air filter/regulator.....	31

1 Safety

1.01 Directives

The machine has been constructed in accordance with the requirements listed in the EC Declaration of Conformity and the Declaration of Incorporation.

In addition to this Instruction Manual, also observe all generally accepted, statutory and other regulations and legal requirements and all valid environmental protection regulations! The regionally valid regulations of the social insurance society for occupational accidents or other supervisory organizations are to be strictly adhered to!

1.02 General notes on safety

- This machine may only be operated by adequately trained operators and only after having completely read and understood the Instruction Manual!
- All Notes on Safety and Instruction Manuals of the motor manufacturer are to be read before operating the machine!
- The danger and safety instructions on the machine itself are to be followed!
- This machine may only be used for the purpose for which it is intended and may not be operated without its safety devices. All safety regulations relevant to its operation are to be adhered to.
- When exchanging sewing tools (e.g. needle, roller presser, needle plate and bobbin), when threading the machine, when leaving the machine unattended and during maintenance work, the machine is to be separated from the power supply by switching off the On/Off switch or by removing the plug from the mains!
- Everyday maintenance work is only to be carried out by appropriately trained personnel!
- Repairs and special maintenance work may only be carried out by qualified service staff or appropriately trained personnel!
- Work on electrical equipment may only be carried out by appropriately trained personnel!
- Work is not permitted on parts and equipment which are connected to the power supply! The only exceptions to this rule are found in the regulations EN 50110.
- Modifications and alterations to the machine may only be carried out under observance of all the relevant safety regulations!
- Only spare parts which have been approved by us are to be used for repairs! We expressly point out that any replacement parts or accessories which are not supplied by us have not been tested and approved by us. The installation and/or use of any such products can lead to negative changes in the structural characteristics of the machine. We are not liable for any damage which may be caused by non-original parts.

1.03

Safety symbols



Danger!
Special points to observe.



Danger of injury to operating or technical staff!



Caution

Do not operate without finger guard and safety devices. Before threading, changing bobbin and needle, cleaning etc. **switch off main switch.**

1.04

Important notes for the user

- This instruction manual belongs to the equipment of the machine and must be available to the operating staff at all times.
- This instruction manual must be read before the machine is operated for the first time.
- Both operating and technical staff must be instructed on the safety devices of the machine and on safe working methods.
- It is the duty of the user to operate the machine in perfect running order only.
- The user must ensure that none of the safety devices are removed nor put out of working order.
- The user must ensure that only authorized persons operate and work on the machine.

For further information please refer to your PFAFF agency.

1.05 Notes for operating and technical staff

1.05.01 Operating staff

Operating staff are the persons responsible for setting up, operating and cleaning the machine and for removing any disturbances in the sewing area.

The operating staff are obliged to observe the following points, and must:

- always observe the notes on safety in this instruction manual!
- avoid using any working methods which adversely effect the safety of the machine!
- avoid wearing loose-fitting clothing or jewelry such as necklaces or rings!
- also ensure that only authorized persons are allowed near the danger area of the machine!
- immediately report to the user any changes to the machine that may affect its safety!

1.05.02 Technical staff

Technical staff are persons who have been trained in electrical engineering, electronics, pneumatics and mechanical engineering. They are responsible for lubricating, servicing, repairing and adjusting the machine.

The technical staff are obliged to observe the following points, and must:

- always observe the notes on safety in this instruction manual!
- switch off the on/off switch before carrying out adjustment and repair work and ensure it cannot be switched on again unintentionally!
- never work on parts or equipment still connected to the power supply! Exceptions to this are only permissible according to regulations **EN 50110**;
- disconnected the machine from the compressed air supply when carrying out maintenance or repair work on pneumatic equipment!
- Exceptions to this are only permissible for function checks;
- replace all safety covers after carrying out maintenance or repair work!

1.06

Danger warnings



A working area of 1 m must be kept free both in front of and behind the machine, so that easy access is possible at all times.



Never put your hands in the sewing area during sewing!
Danger of injury by the needle!



While setting or adjusting the machine do not leave any objects on the table nor in the needle plate area! Objects may be trapped or slung out of the machine!

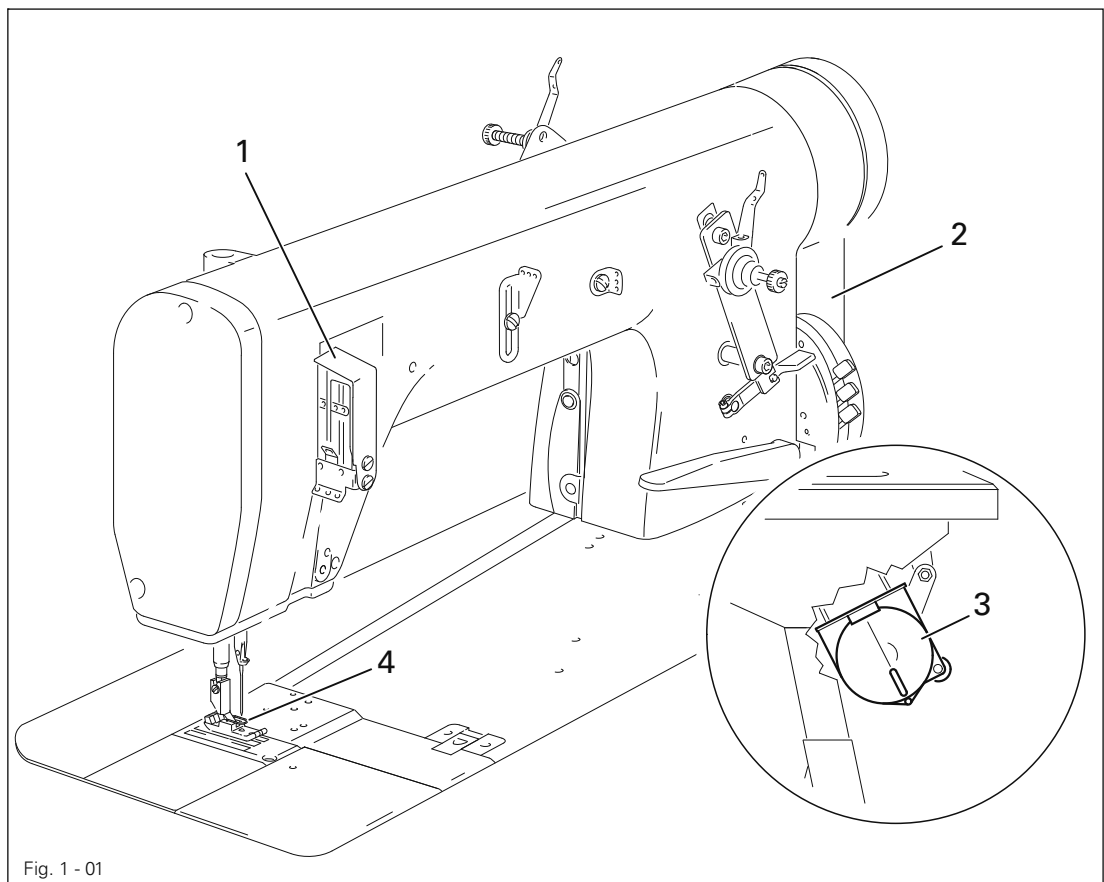

Fig. 1 - 01



Do not operate the machine without take-up lever guard 1!
Danger of injury from the movement of the take-up lever!



Do not operate the machine without belt guard 2 and 3!
Danger of injury by running drive belts!



Do not operate the machine without finger guard 4!
Danger of injury by the needle!

2 Proper use

The PFAFF 5489 is an ultra-high-speed chainstitch sewing machine with differential bottom feed for production of chainstitch seams.

The machine is intended for commercial (industrial) use.



Any use of these machines which is not approved by the manufacturer shall be considered as improper use! The manufacturer shall not be liable for any damage arising out of improper use! Proper use shall also be considered to include compliance with the operation, adjustment, service and repair measures specified by the manufacturer!

Specifications

3 Specifications ♦

3.01 PFAFF 5489

Stitch type:..... 401 (two-thread chainstitch)

Needle system:..... 4463-35

Model :..... B

Needle thickness in 1/100 mm: 80 - 100

Max. stitch length: 4,5 mm

Max.thread size (synthetic):..... 40/3▲

Dimensions of the machine:

Length:..... approx. 580 mm

Breadth: approx. 177 mm

Height (above table): approx. 265 mm

Clear workspace width: 260 mm

Clear workspace height: 130 mm

Noise data:

Noise emission level at workplace with a sewing speed of 4800 spm: $L_{pA} < 83$ dB(A)■
(Noise measurement in accordance with DIN 45 635-48-A-1, ISO 11204, ISO 3744, ISO

Motor data: See instruction manual for the motor

Working pressure:..... 6 bar

Air consumption per switch cycle: ~ 0,146 l

Net weight (sewing head):..... approx. 39 kg

Gross weight (sewing head): approx. 47 k

♦ Subject to alterations

3.02 Models and work aids

Model B: For sewing medium materials

Mögliche Zusatzeinrichtungen:

Possible work aids:

Subclass -900/71..... Thread trimmer

Subclass -910/..... Automatic foot lift

Subclass -917/..... Stitch condensation system

Subclass -918/14..... Various controls

Subclass -948/26..... Puller feed

Subclass -971/..... Photocell control

▲ synthetic, or other sizes of comparable thread types

■ $K_{pA} = 2,5$ dB

4 Disposal of Machine

- Proper disposal of the machine is the responsibility of the customer.
- The materials used for the machine are steel, aluminium, brass and various plastic materials. The electrical equipment comprises plastic materials and copper.
- The machine is to be disposed of according to the locally valid pollution control regulations; if necessary, a specialist is to be commissioned.



Care must be taken that parts soiled with lubricants are disposed of separately according to the locally valid pollution control regulations!

5 Transportation, packing and storage

5.01 Transportation to customer's premises

The machines are delivered completely packed.

5.02 Transportation inside the customer's premises

The manufacturer cannot be made liable for transportation inside the customer's premises nor to other operating locations. It must be ensured that the machines are only transported in an upright position.

5.03 Disposal of packing materials

The packing materials of this machine comprise paper, cardboard and VCE fibre. Proper disposal of the packing material is the responsibility of the customer.

5.04 Storage

If the machine is not in use, it can be stored as it is for a period of up to six months, but it should be protected against dust and moisture.

If the machine is stored for longer periods, the individual parts, especially the surfaces of moving parts, must be protected against corrosion, e.g. by a film of oil.

6 Explanation of symbols

In this instruction manual, work to be carried out or important information is accentuated by symbols. These symbols have the following meanings:



Note, information



Cleaning, care



Lubrication

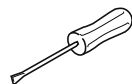

Maintenance, repairs, adjustment, service work
(only to be carried out by technical staff)

7 Controls

7.01 Main switch

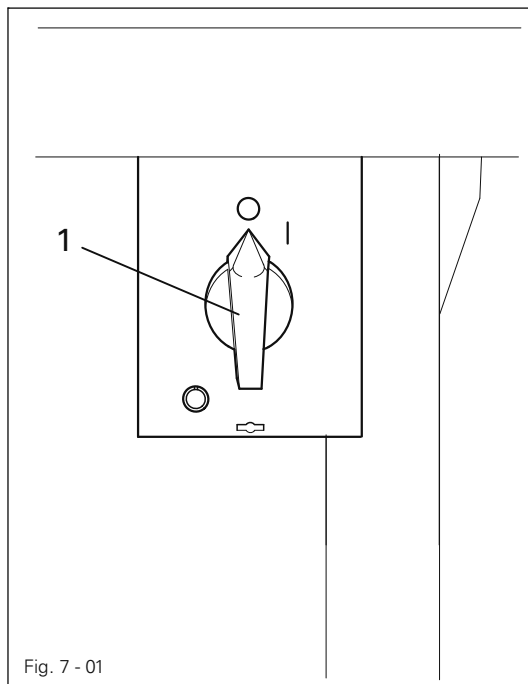

- The machine is switched on or off by turning main switch 1.

7.02 Pedal

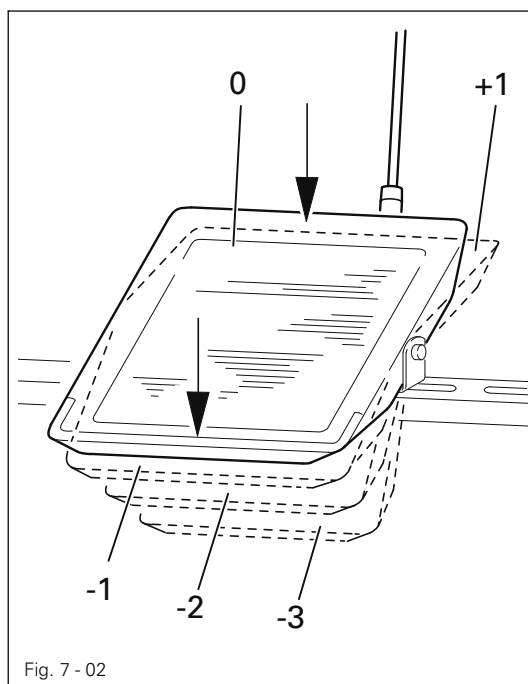

- With the on/off switch on
 - 0 = Machine stop
 - +1 = sewing, up to maximum speed
 - 1 = Raise presser foot
 - 2 = Raise puller roller
(on machines with -948/26)
 - 3 = Trim thread
(on machines with -900/..)

7.03 Keys on the machine head

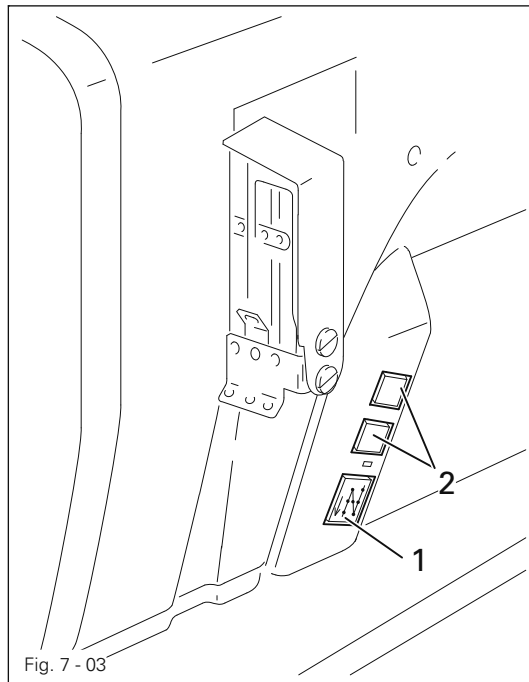

- As long as key 1 is pressed during sewing, the machine sews in reverse.
- Keys 2 can be used for parameter settings (see parameter 748 and 446 in the instruction manual for the motor).

7.04 Raising the presser foot

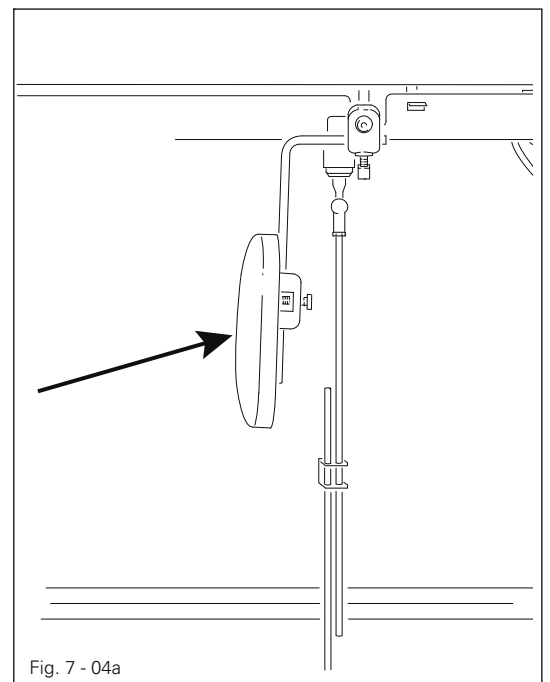
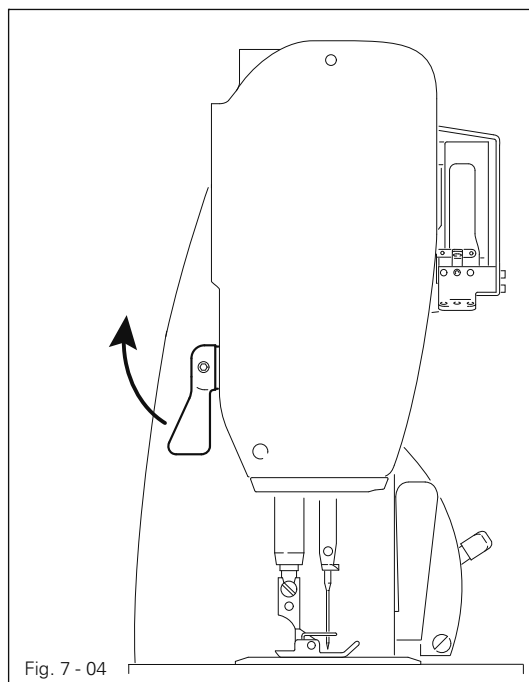

7.05 Thread tension release lever

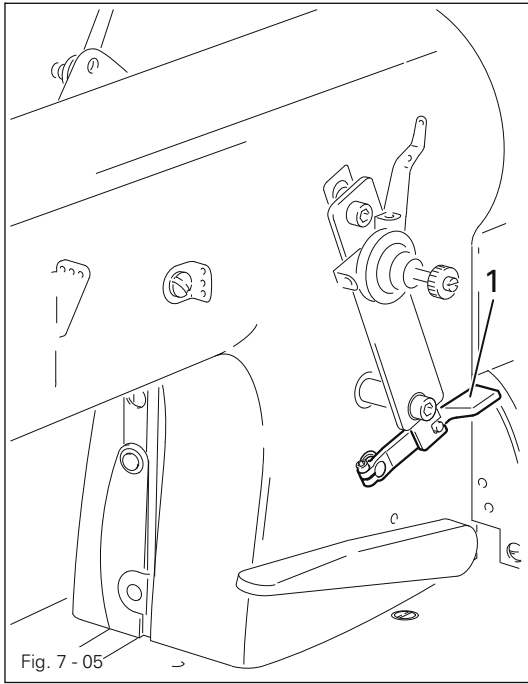

- To release the thread tension push lever 1 downwards.

7.06 Reverse feed lever

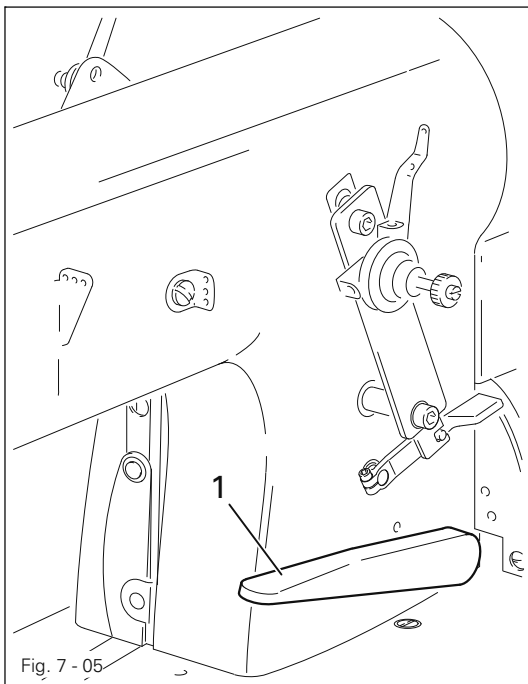

- To sew condensed stitches, press lever 1 down.

7.07 **Stitch length and Differential feed levers**

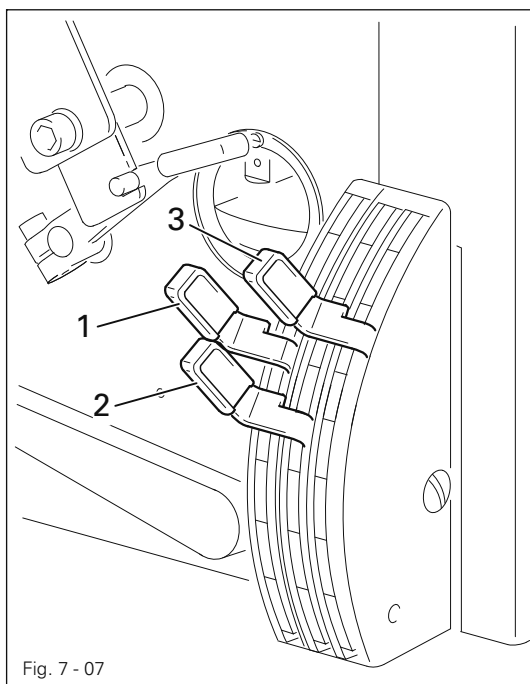

- To set the stitch length, press lever 1 a little to the right and move it to the required stitch length.
- Adjustment levers 1 and 2 are used to adjust the differential feed stroke (also see Chapter 9.04 Adjusting the differential feed).

7.08 **Control panel**

The description can be found in the separate instruction manual for the motor.

7.09 **Puller (-948/26)**

The description can be found in the separate instruction manual for the Puller.

8 Installation and commissioning

The machine must only be mounted and commissioned by qualified personnel!
All relevant safety regulations are to be observed!



If the machine is delivered without a table, it must be ensured that the frame and the table top which you intend to use can hold the weight of the machine and the motor. It must be ensured that the supporting structure is sufficiently sturdy, including during all sewing operations.

8.01 Installation

The site where the machine is installed must be provided with suitable connections for the electric current, see Chapter 3 **Specifications**.

It must also be ensured that the standing surface of the machine site is firm and horizontal, and that sufficient lighting is provided.



The method of packaging used requires that the table top be lowered for transport. The following is a description of how to adjust the height of the table top.

8.01.01 Adjusting the table-top height

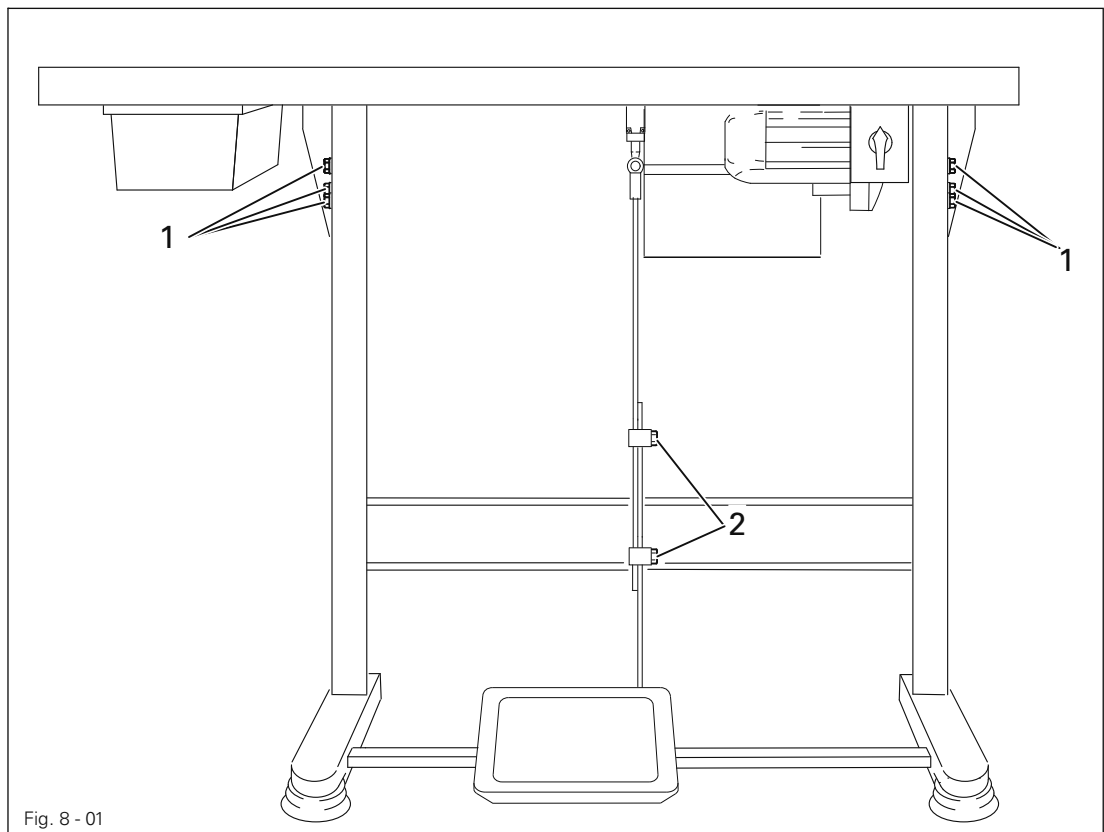
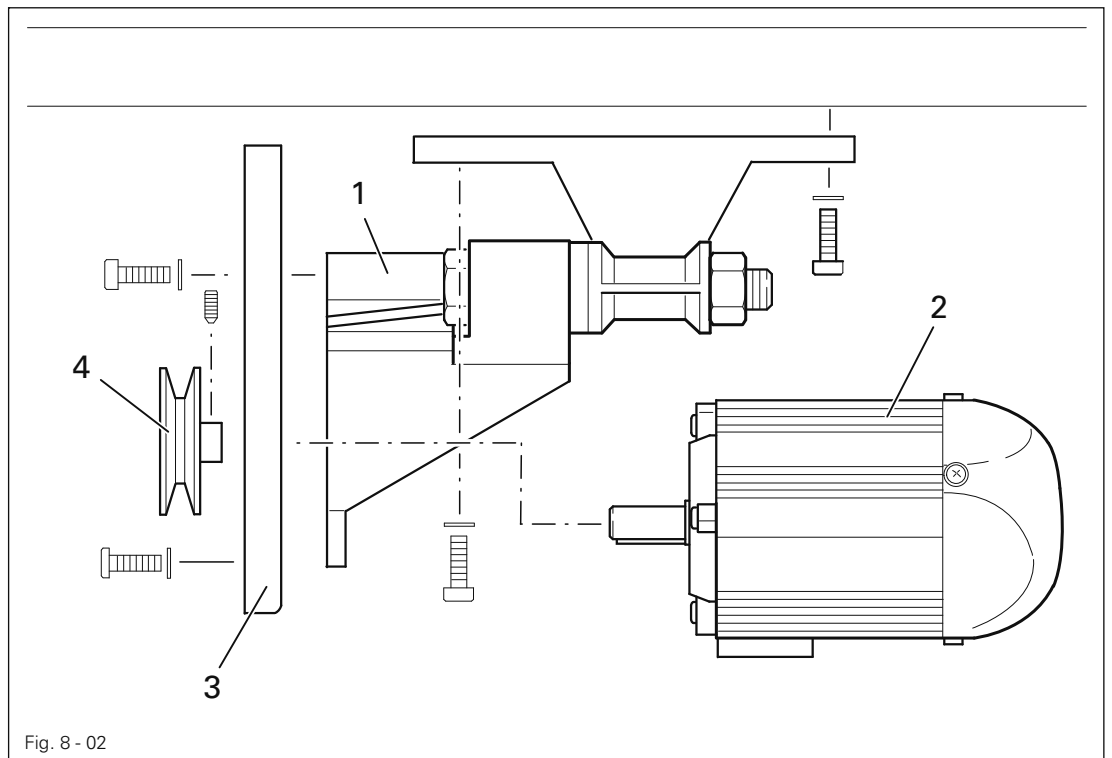

Fig. 8 - 01

- Loosen screws 1 and 2 and set the desired table-top height
- Tighten screws 1 well.
- Adjust the position of the pedal so that you can operate it comfortably and tighten screw 2.

8.01.02 Assembling the motor P40 ED



- Assemble motor mounting 1, motor 2, belt guard support 3 and belt pulley 4 as shown in Fig. 8-02.

8.01.03 Tightening the V-belt

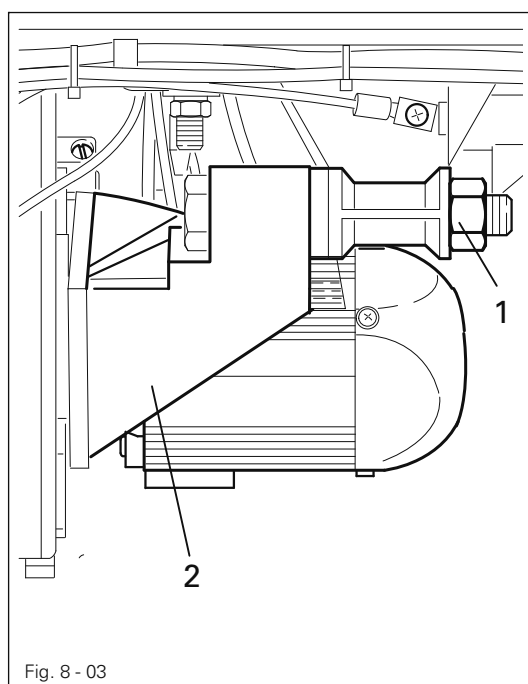

- Fit the V-belt.
- Loosen nut 1 and tighten the V-belt by turning motor mounting 2.
- Tighten nut 1.

8.01.04 Mounting the bottom V-belt guard

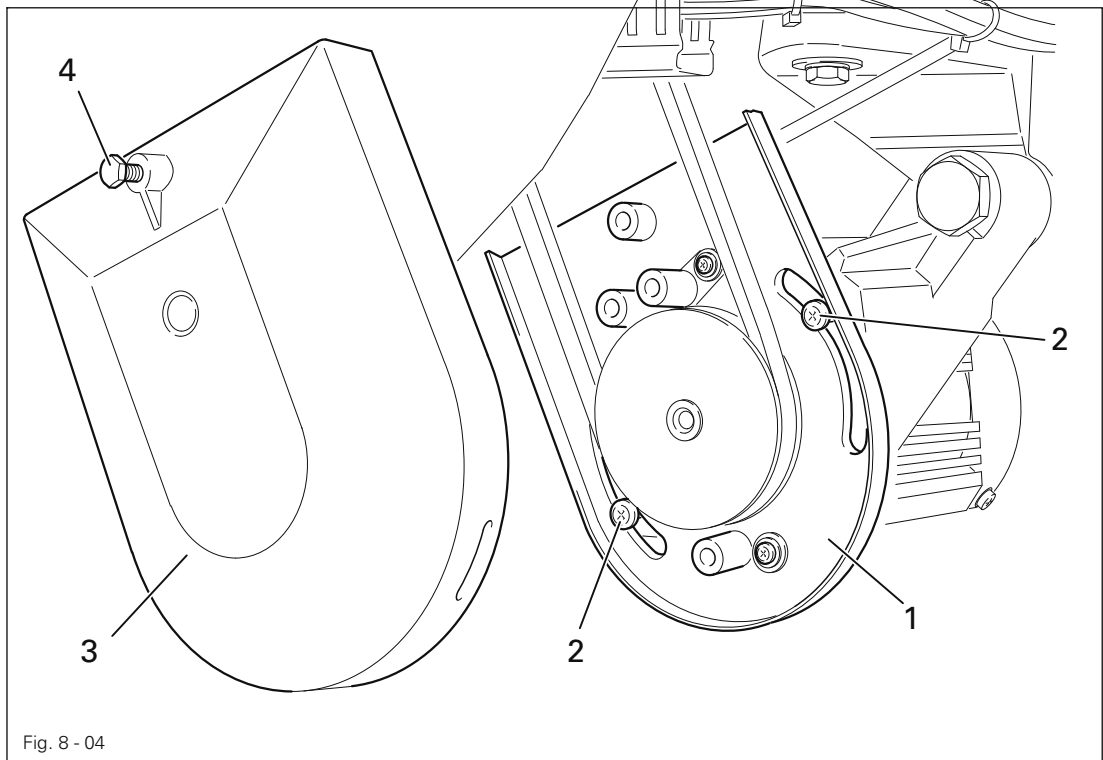

- Loosen screws 2 and adjust belt guard support 1 so that the motor pulley and V-belt run freely.
- Tighten screws 2.
- Fasten belt guard 3 with screw 4.

8.01.05 Fitting the upper belt guard

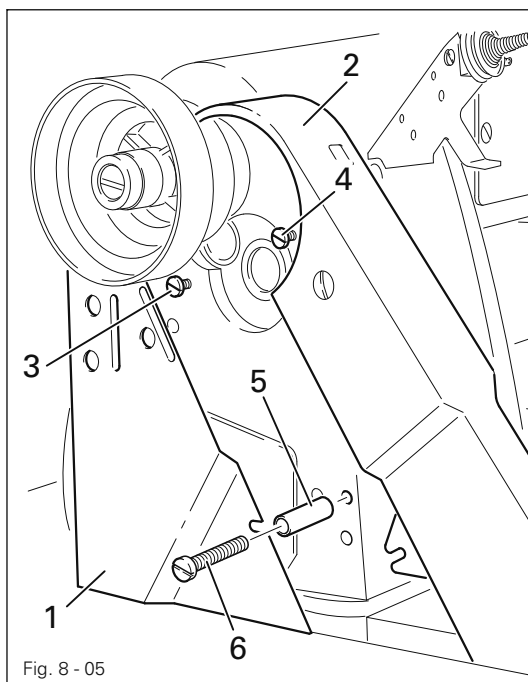

- Push belt guard halves 1 and 2 with their slots behind the heads of screws 3 and 4.
- Fit spacing sleeve 5 on screw 6 and wind screw 6 in a few turns.
- Making sure that the lug on belt guard half 2 is between belt guard half 1 and spacing sleeve 5, position the belt guard and tighten screws 3, 4 and 6.

8.01.06 Fitting the synchronizer

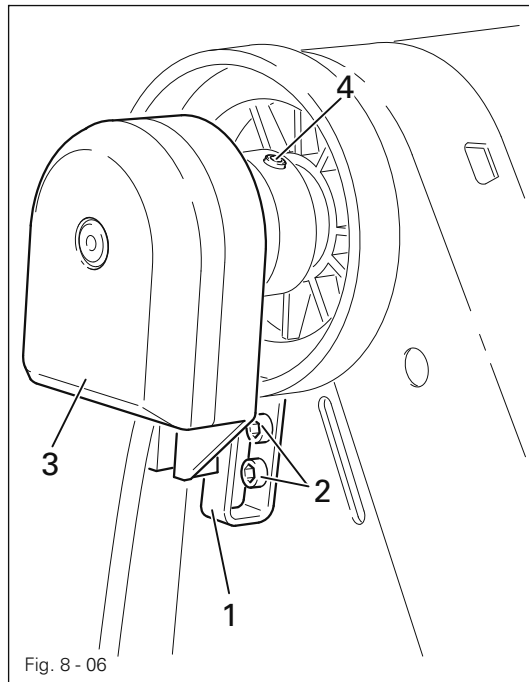

- Screw on stop 1 with screws 2.
- Place synchronizer 3 on the shaft so that stop 1 is in the slot of synchronizer 3, see arrow.
- Tighten screws 4.
- Insert the synchronizer plug into the adapter (see Chapter 8.02 Connecting the plug-in connections and earth cables).

8.01.07 Fitting the reel stand

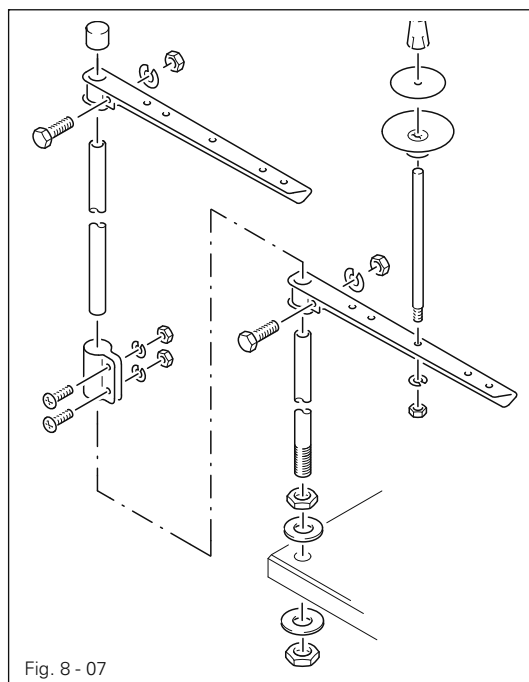

- Fit the reel stand as shown in Fig. 8 - 07.
- Afterwards insert the stand in the hole in the table top and secure it with nuts provided.

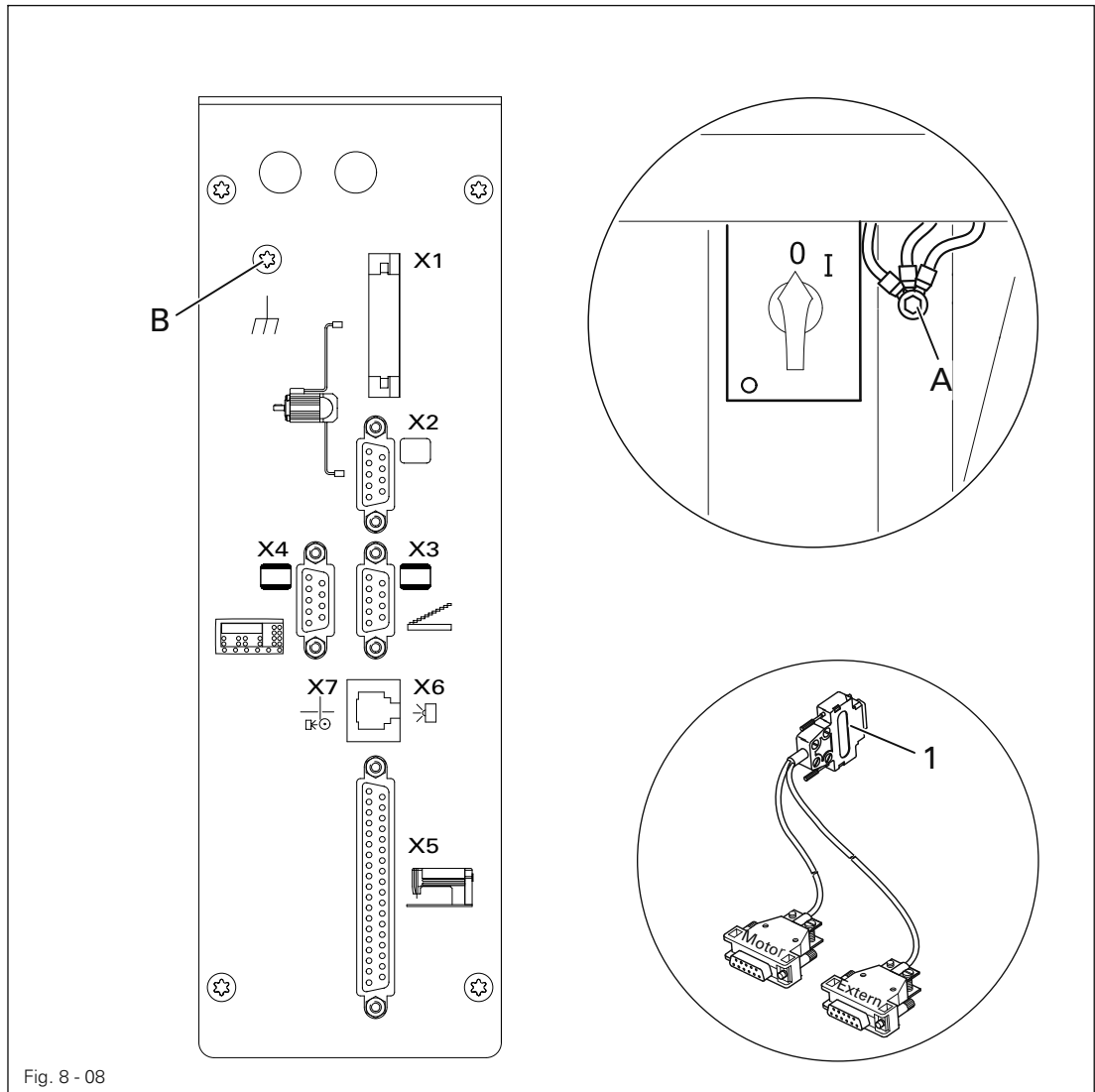

Fig. 8 - 08

- Connect all plugs as labelled to the control box .
- Screw the earth cable from the sewing head and the main switch to earth point **A**.
- Connect earth point **A** to earth point **B** with earth cable.
- Insert plug **1** from the adapter cable to bush **X 2**.
- Connect the motor to the "**Motor**" plug and the synchronizer to the "**Extern**" plug.
- Fasten the earth cable from plug **X1** to earth point **B**.

8.03 Commissioning

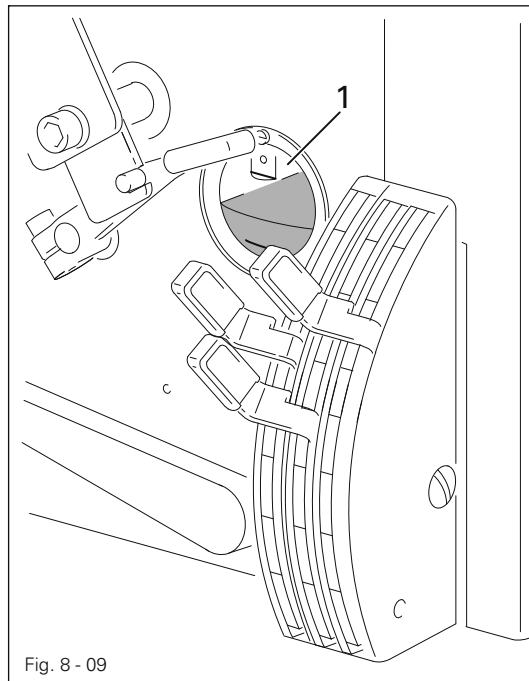

Fig. 8 - 09



Before setting up, remove the protective foil from oil glass 1!

- Check the machine, particularly its electrical wiring and pneumatic tube connections, for any damage.
- Clean the machine thoroughly and oil it (see chapter 10 Care and maintenance).
- Have skilled personnel check if the machine can be operated with the available mains voltage.



Do not operate the machine if there is any discrepancy.



Before commissioning the machine, have specialized personnel check whether the parameter 799 (machine class) is set at "1" and the parameter 800 (sewing direction) is set at "0". If necessary, have the adjustment carried out (see Chapter 8.05 Basic position of the machine drive unit).



The machine may only be connected to an earthed socket!

- Connect the machine to the compressed air supply. When it is connected, the gauge should show a pressure of approx. 6 bar. If necessary, have this reading correctly set (see Chapter 10.04, Checking/adjusting the air pressure)

8.04 Switching the machine on/off

- Switch the machine on (see Chapter 7.01, On/off switch).

8.05 Basic position of the machine drive unit P40ED

- Switch on the machine.
- Press the **TE/speed key twice** to select the input mode.
- Select parameter "798" by pressing the corresponding +/- key, and select service level C, see Chapter **Selecting the user level** in the instruction manual for the control panel.
- By pressing the corresponding +/- key select the parameter "799" (Selecting the machine class).
- Check whether value "1" is set, and correct it if necessary.



If the parameter has to be altered, operate the **TE/Speed** key and then switch off the machine and switch it on again. Then select service level C again as described above.

- By pressing the corresponding +/- key, select parameter "800" (selecting the sewing direction).
- By pressing the corresponding +/- key, select the value for the parameter at "0".
- By pressing the corresponding +/- key, select parameter "700".
- Sew a stitch by operating the pedal.
- Turn the balance wheel in the sewing direction until the descending needle is level with the top edge of the needle plate.
- Conclude the adjustment of the sewing motor by pressing the **TE/Speed key**.

9

Setting up



All instructions and regulations in this instruction manual must be observed. Special attention must be given to all safety regulations!



All setting-up work must only be done by personnel with the necessary training. For all setting-up work the machine must be isolated from its power supply by turning off the main switch or removing the machine plug from the electric power socket!

9.01

Inserting the needle

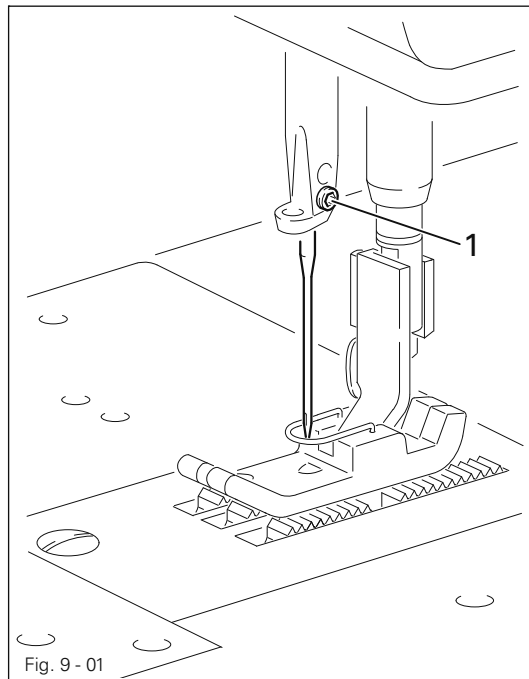

Switch off the machine!
Danger of injury due to unintentional starting of the machine!



Only use needles from the system intended for the machine, see Chapter 3 **Specifications**.

- Set the needle bar at its highest point.
- Loosen screw 1.
- Push needle fully into the needle bar (the long needle groove must face to the front).
- Tighten screw 1.

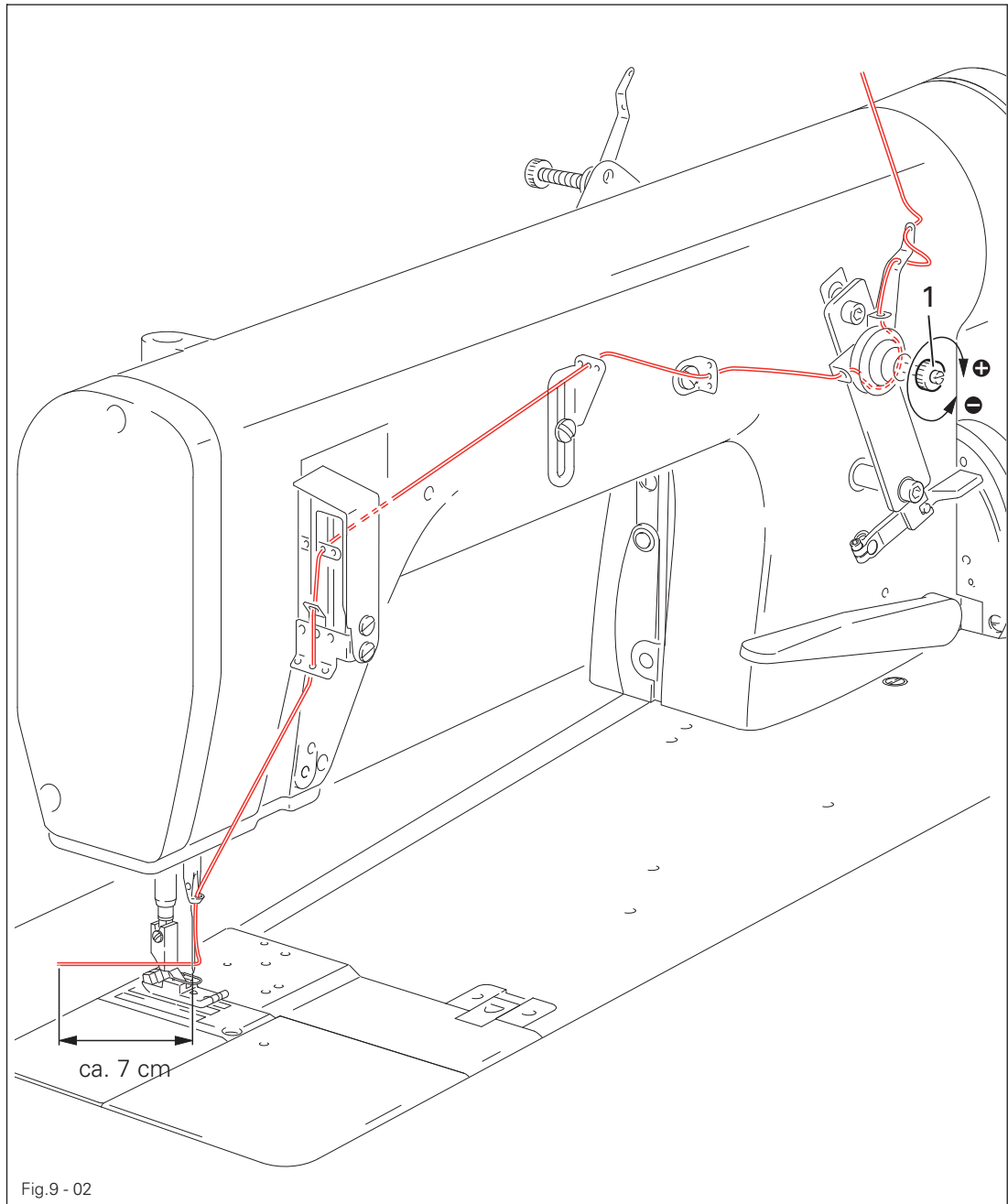

Switch off the machine!

Danger of injury due to unintentional starting of the machine!

- Thread the needle thread as shown in Fig. 9-02.
- Regulate the needle thread by turning knurled screw 1.

9.03 Threading the looper thread and regulating its tension

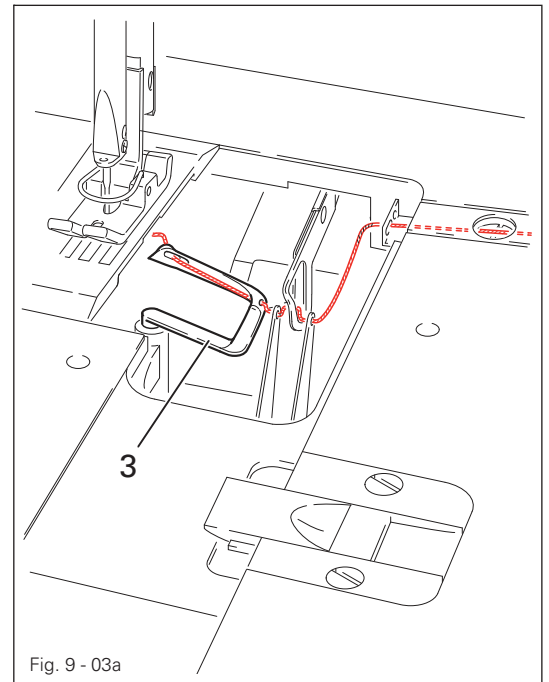
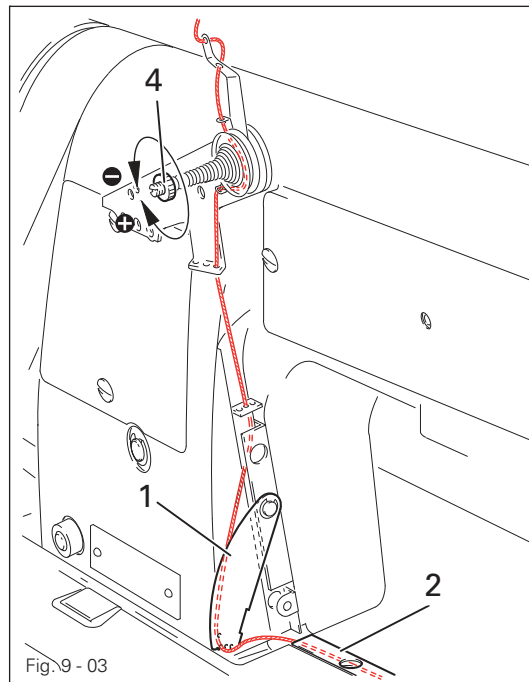

Switch off the machine!
 Danger of injury due to unintentional starting of the machine!

- Open the looper cover and swing out thread guide plate 1.
- Thread the looper thread as shown in Figs. 9-03 and 9-03a and pull it under guide plate 2.
- Thread looper 3 using tweezers.
- Regulate the looper thread by turning knurled screw 4.
- To pull the thread through, release thread tension (see Chapter 7.05)

Adjusting the differential feed

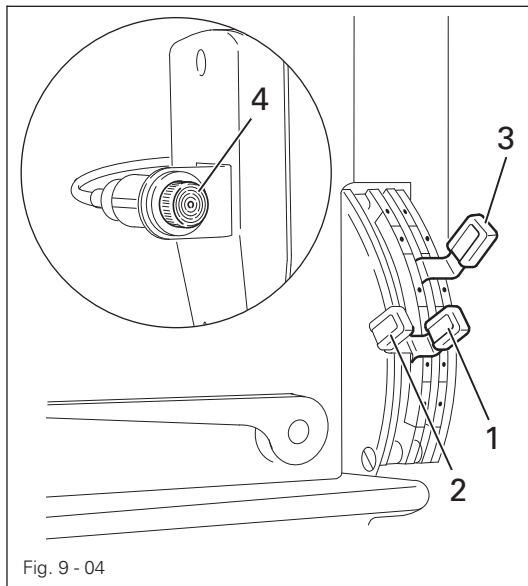

Fig. 9 - 04

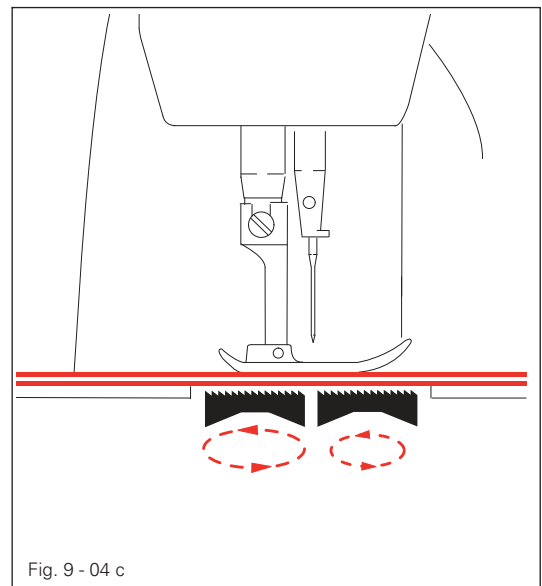

Fig. 9 - 04 c

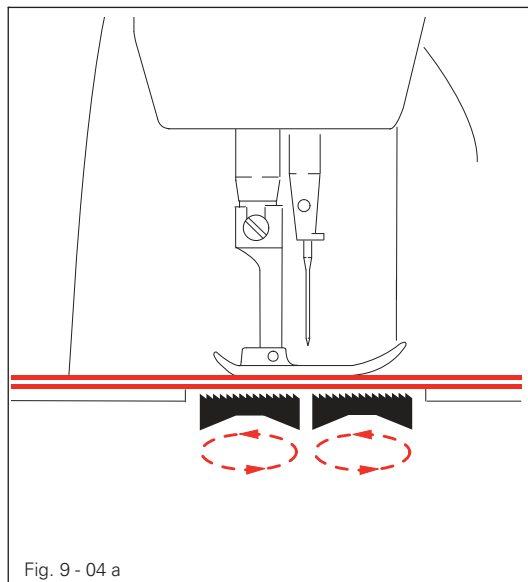

Fig. 9 - 04 a

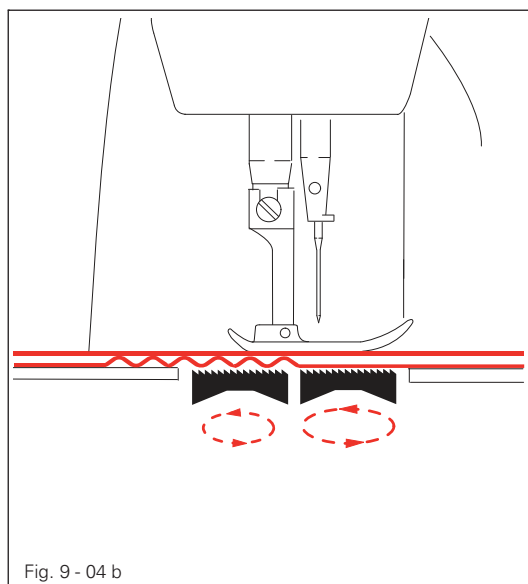

Fig. 9 - 04 b

- **Standard sewing**

- **Set lever 1 and 2 at the same value.**
The main and the differential feed operate with the same feed stroke (see Fig. 9-04a).

- **Lower fullness**

- **Set lever 1 at a higher value than lever 2.**
The differential feed dog applies fullness to the lower material ply (see Fig. 9-04 b.)
On machines with subclass -918/14 lever 3 is used to limit a second differential feed value.

It is possible to change from one value to the other by using the keys on the machine head.

The display 4 on the machine head shows whether the machine is operating with standard value or fullness.

Green = standard value

White = fullness

- **Stretching the lower material ply**

- **Set lever 1 at a lower value than lever 2.**
The lower material ply is stretched (see 9-04 c).

10 Care and maintenance

10.01 Servicing and maintenance intervals

Clean the looper compartment	daily, several times if in continuous operation
Clean the entire machine	once a week
Machine oil level.....	daily before use
Control/adjust air pressure	as required
Clean air filter of the lubricator/air-filter	as required



These maintenance intervals are calculated for the average running time of a single shift operation. If the machine is operated more than this, shorter intervals are recommended.

10.02 Cleaning the machine



The cleaning cycle required for the machine depends on following factors:

- Single or several shift operation
- Amount of dust resulting from the workpiece

It is therefore only possible to stipulate the best possible cleaning instructions for each individual case.



For all cleaning work the machine must be disconnected from the mains by switching off the on/off switch or by removing the mains plug!
Danger of injury if the machine suddenly starts up .

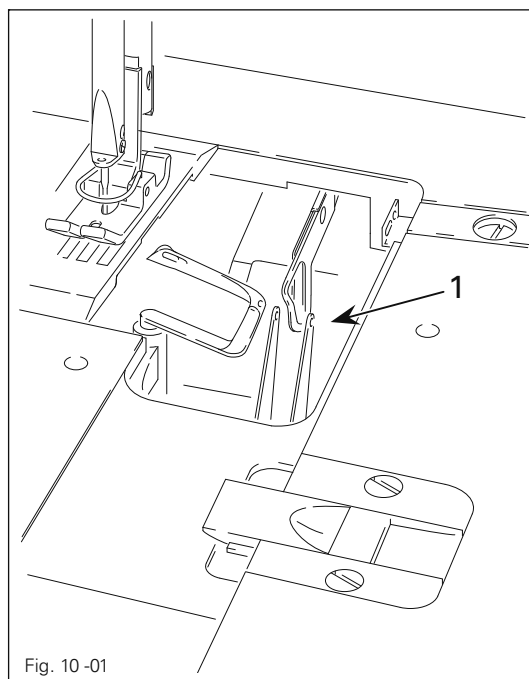

Fig. 10 -01

To avoid breakdowns, the following cleaning work is recommended for single shift operation:

- Open the looper cover.
- Clean the hook compartment 1 daily, several times if in continuous use.
- Close the looper cover !



Do not run the machine with the looper cover open.!
Danger of injury by moving parts.

10.03 Lubricating

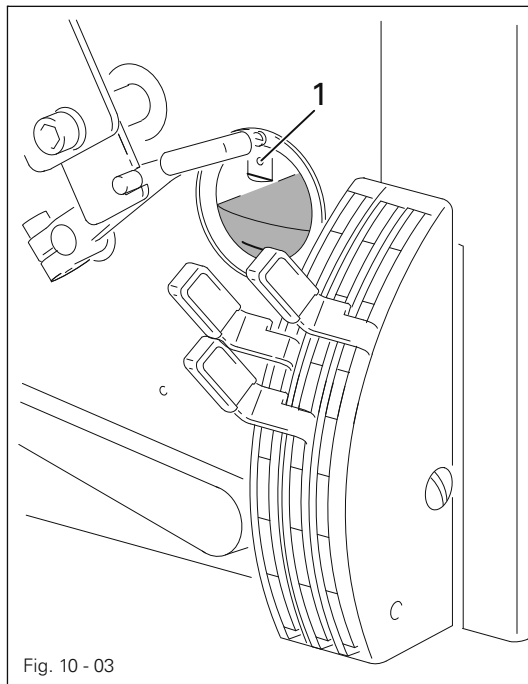

Check the oil level daily before starting the machine!

- The oil level must be between the markings in the inspection glass.
- If required, fill oil into the tank through hole 1.



Only use oil with a medium viscosity of $22.0 \text{ mm}^2/\text{s}$ at 40°C and a density of 0.865 g/cm^3 at 15°C !

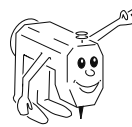

We recommend PFAFF sewing-machine oil, part No. 280-1-120 144.

10.04 Checking/regulating the air pressure

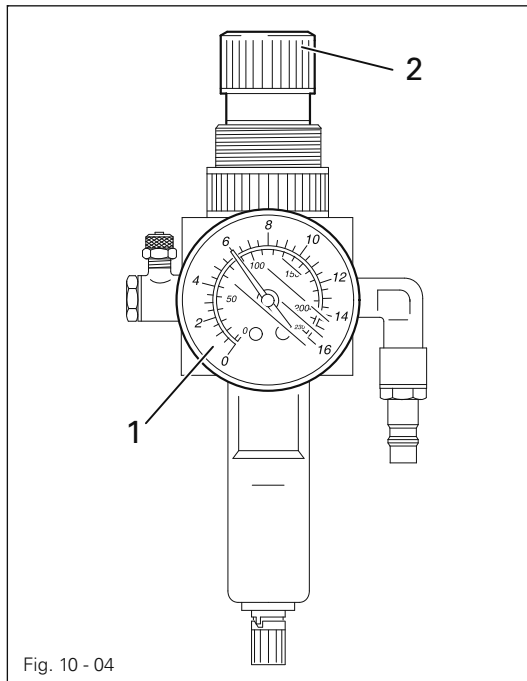

- Check the air pressure on gauge 1 every time before operation.
- Gauge 1 must show a pressure of 6 bar.
- Regulate this pressure if required.
- To do so, pull knob 2 up and turn it accordingly.

10.05 Emptying/cleaning the water bowl of the air filter/regulator

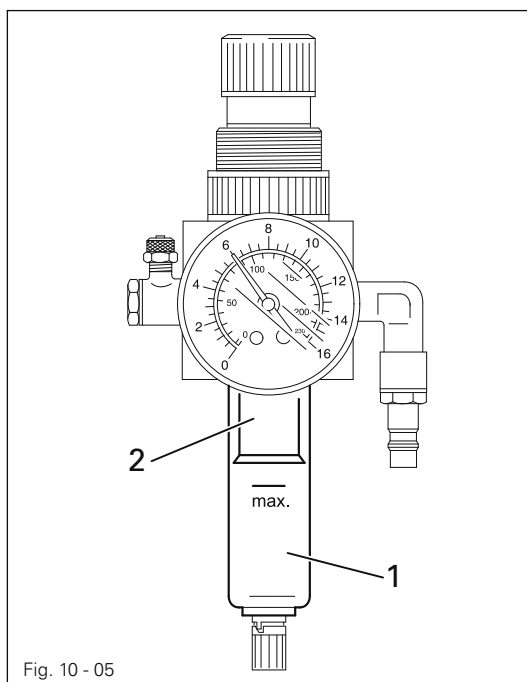

Switch off the machine.
Disconnect the air hose at the air filter/regulating unit.

Emptying the water bowl

- Water bowl 1 empties itself automatically when the air hose is disconnected from the air filter/regulator.

Cleaning the filter

- Unscrew water bowl 1 and take out filter 2.
- Clean the filter with compressed air or with isopropyl-alcohol, part number 95-665735-91.
- Screw in filter 2 and screw on water bowl 1.



Europäische Union
Wachstum durch Innovation – EFRE



PFAFF Industriesysteme und Maschinen AG

Hans-Geiger-Str. 12 - IG Nord
D-67661 Kaiserslautern

Telefon: +49-6301 3205 - 0
Telefax: +49-6301 3205 - 1386
E-mail: info@pfaff-industrial.com