

1122

1122-G

INSTRUCTION MANUAL

1122-720/02

1122-G-720/02

This instruction manual applies to machines from the following serial numbers onwards:

6 001 000 →



This Instruction Manual is valid for all models and subclasses listed in the chapter "**Specifications**".



The adjustment manual for the machines can be downloaded free of charge from the internet address

www.pfaff-industrial.com/pfaff/de/service/downloads

As an alternative to the internet download the adjustment manual can also be ordered in book form under part no. **296-12-18 582/002**.

The reprinting, copying or translation of PFAFF Instruction Manuals, whether in whole or in part, is only permitted with our previous authorization and with written reference to the source.

**PFAFF Industriesysteme
und Maschinen AG**

Hans-Geiger-Str. 12 - IG Nord
D-67661 Kaiserslautern

	Contents	Chapter - Page
1	Safety	1 - 1
1.01	Directives	1 - 1
1.02	General notes on safety	1 - 1
1.03	Safety symbols	1 - 2
1.04	Important points for the user	1 - 2
1.05	Operating and specialist personnel	1 - 3
1.05.01	Operating personnel	1 - 3
1.05.02	Specialist personnel	1 - 3
1.06	Danger	1 - 4
2	Proper use.....	2 - 1
3	Specifications	3 - 1
4	Disposal of machine	4 - 1
5	Transport, packaging and storage	5 - 1
5.01	Transport to the customer	5 - 1
5.02	Transport within the customer's premises	5 - 1
5.03	Disposal of the packaging	5 - 1
5.04	Storage	5 - 1
6	Explanation of the symbols	6 - 1
7	Controls	7 - 1
7.01	On/off switch	7 - 1
7.02	Pedal	7 - 1
7.03	Lever for lifting the presser foot.....	7 - 2
7.04	Knee lever	7 - 2
7.05	Key on the machine head (only on machines with backtacking device -911/93)	7 - 3
7.06	Reverse feed key	7 - 3
7.07	Stitch length adjustment wheel	7 - 4
7.08	Switching needles (only on machines with disengagable needles -720/02)	7 - 4
7.09	Switch for the thread wiper (only on machines with thread wiper -909/93)	7 - 5
7.10	Control panel (only on machines with Quick-motor)	7 - 6
7.10.01	Screen displays	7 - 6
7.10.02	Function keys	7 - 6
8	Installation and commissioning	8 - 1
8.01	Installation	8 - 1
8.01.01	Adjusting the table height	8 - 1
8.01.02	Assembling the oil pan	8 - 2
8.01.03	Mounting the sewing head	8 - 2
8.01.04	Assembling the motor (only on machines with Quick-motor)	8 - 3
8.01.05	Tightening the V-belt	8 - 3

Contents

	Contents	Chapter - Page
8.01.06	Mounting the bottom V-belt guard	8 - 4
8.01.07	Mounting the top V-belt guard	8 - 5
8.01.08	Fitting the reel stand	8 - 5
8.01.09	Connecting the plug-in connections and earth cables	8 - 6
8.02	Commissioning	8 - 7
8.02.01	Switching on the machine and executing the pulley function	8 - 7
8.02.02	Basic position of the machine drive unit (only on machines with Quick motor).....	8 - 8
8.03	Table top cutout	8 - 9
8.04	Mounting the table top	8 - 10
9	Setting up	9 - 1
9.01	Inserting the needle	9 - 1
9.02	Winding the bobbin thread	9 - 2
9.03	Changing the bobbin on the PFAFF 1122-720/02	9 - 3
9.04	Changing the bobbin (on machines with drop-in hook)	9 - 4
9.05	Threading the needle thread / adjusting the needle thread tension	9 - 5
9.06	Adjusting the stitch length	9 - 6
9.07	Entering start and end backtacks (only on machines with Quick motor)	9 - 6
9.08	Setting the stitch counting function for monitoring the bobbin thread	9 - 7
10	Care and maintenance	10 - 1
10.01	Maintenance intervals	10 - 1
10.02	Cleaning the machine	10 - 1
10.03	Cleaning the hook compartment	10 - 2
10.04	Oiling the machine	10 - 3
10.05	Oiling the hook race	10 - 4
10.06	Oiling the head parts	10 - 4
10.07	Oil disposal	10 - 5
11	Wearing parts	11 - 1

1 Safety

1.01 Directives

This machine is constructed in accordance with the European regulations contained in the conformity and manufacturer's declarations.

In addition to this Instruction Manual, also observe all generally accepted, statutory and other regulations and legal requirements and all valid environmental protection regulations!

The regionally valid regulations of the social insurance society for occupational accidents or other supervisory organizations are to be strictly adhered to!

1.02 General notes on safety

- This machine may only be operated by adequately trained operators and only after having completely read and understood the Instruction Manual!
- All Notes on Safety and Instruction Manuals of the motor manufacturer are to be read before operating the machine!
- The danger and safety instructions on the machine itself are to be followed!
- This machine may only be used for the purpose for which it is intended and may not be operated without its safety devices. All safety regulations relevant to its operation are to be adhered to.
- When exchanging sewing tools (e.g. needle, roller presser, needle plate and bobbin), when threading the machine, when leaving the machine unattended and during maintenance work, the machine is to be separated from the power supply by switching off the On/Off switch or by removing the plug from the mains!
- Everyday maintenance work is only to be carried out by appropriately trained personnel!
- Repairs and special maintenance work may only be carried out by qualified service staff or appropriately trained personnel!
- Work on electrical equipment may only be carried out by appropriately trained personnel!
- Work is not permitted on parts and equipment which are connected to the power supply! The only exceptions to this rule are found in the regulations EN 50110.
- Modifications and alterations to the machine may only be carried out under observance of all the relevant safety regulations!
- Only spare parts which have been approved by us are to be used for repairs! We expressly point out that any replacement parts or accessories which are not supplied by us have not been tested and approved by us. The installation and/or use of any such products can lead to negative changes in the structural characteristics of the machine. We are not liable for any damage which may be caused by non-original parts.

1.03

Safety symbols



Danger!
Points to be observed.



Danger of injury for operating and specialist personnel!

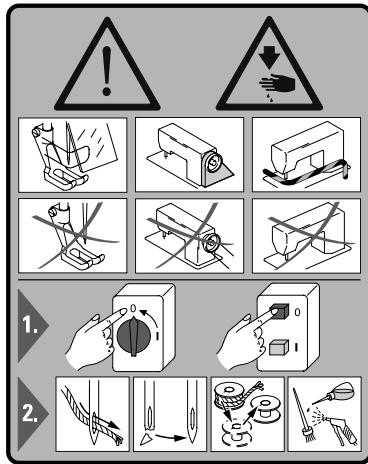

Caution

Do not operate without finger guard and safety devices.
Before threading, changing bobbin and needle, cleaning
etc. **switch off main switch.**

1.04

Important points for the user

- This Instruction Manual is an integral part of the machine and must be available to the operating personnel at all times.
- The Instruction Manual must be read before operating the machine for the first time.
- The operating and specialist personnel is to be instructed as to the safety equipment of the machine and regarding safe work methods.
- It is the duty of the user to only operate the machine in perfect running order.
- It is the obligation of the user to ensure that none of the safety mechanisms are removed or deactivated.
- It is the obligation of the user to ensure that only authorized persons operate and work on the machine.

Further information can be obtained from your PFAFF agent.

1.05 Operating and specialist personnel

1.05.01 Operating personnel

Operating personnel are persons responsible for the equipping, operating and cleaning of the machine as well as for taking care of problems arising in the sewing area.

The operating personnel is required to observe the following points and must:

- always observe the Notes on Safety in the Instruction Manual!
- never use any working methods which could adversely affect the safety of the machine!
- not wear loose-fitting clothing or jewelery such as chains or rings!
- also ensure that only authorized persons have access to the potentially dangerous area around the machine!
- always immediately report to the person responsible any changes in the machine which may limit its safety!

1.05.02 Specialist personnel

Specialist personnel are persons with a specialist education in the fields of electrics, electronics and mechanics. They are responsible for the lubrication, maintenance, repair and adjustment of the machine.

The specialist personnel is obliged to observe the following points and must:

- always observe the Notes on Safety in the Instruction Manual!
- switch off the On/Off switch before carrying out adjustments or repairs, and ensure that it cannot be switched on again unintentionally!
- wait until the luminous diode on the control box is no longer blinking or on before beginning adjustment or repair work.
- never work on parts which are still connected to the power supply! Exceptions are explained in the regulations EN 50110.
- replace the protective coverings and close the electrical control box after all repairs or maintenance work!

1.06

Danger



A working area of 1 meter is to be kept free both in front of and behind the machine while it is in operation so that it is always easily accessible.



Never reach into the sewing area while sewing! Danger of injury by the needle!



Never leave objects on the table while adjusting the machine settings! Objects can become trapped or be slung away! Danger of injury!



When using mechanically operated clutch motors without an operating lock, wait until the motor has stopped! Danger of injury!

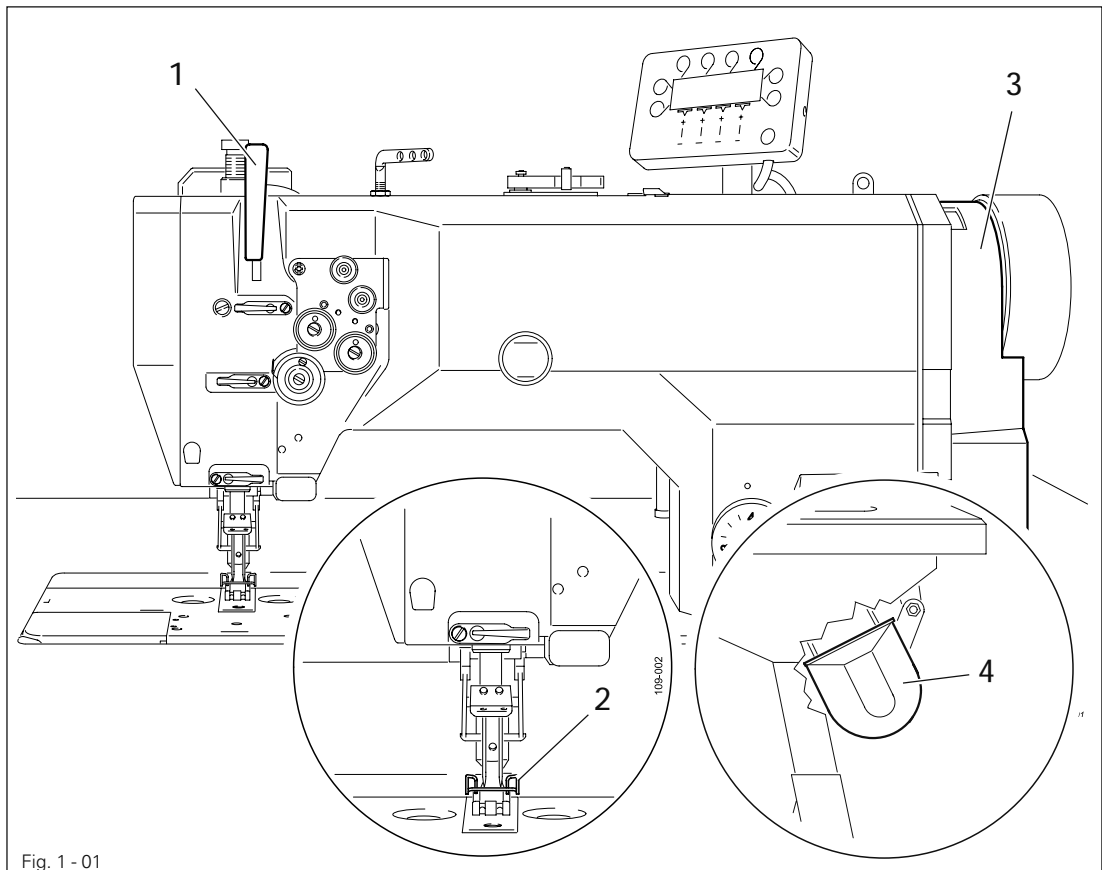

Fig. 1 - 01



Do not operate the machine without its take-up lever guard 1!
Danger of injury due to the motion of the take-up lever!



Do not operate the machine without the finger guard 2!
Danger of injury by the needle!



If an external motor is used, do not operate the machine without the belt guards 3 and 4!
Danger of injury by the drive belt!

2

Proper use

The PFAFF 1122 is a two-needle, lockstich sewing machine with needle feed and vertical hook.

The PFAFF 1122-G is a two-needle, lockstich sewing machine with needle feed and large vertical hook.

The PFAFF 1122-720/.. is a two-needle, lockstich sewing machine with needle feed, vertical hook, and disengagable needles.

The PFAFF 1122-G-720/.. is a two-needle, lockstich sewing machine with needle feed, large vertical hook and disengagable needles.

All machines are used for sewing lockstitch seams in the textile and leather industry.



Any and all uses of this machine which have not been approved of by the manufacturer are considered to be inappropriate! The manufacturer cannot be held liable for any damage caused by the inappropriate use of the machine!
The appropriate use of the machine includes the observance of all operational, adjustment, maintenance and repair measures required by the manufacturer!

3 Specifications

3.01 General specifications ▲

Stitch type: 310 (lockstitch)
Needle system: DPx5
Thread size: 30/3
(synthetic or similar sizes of other thread types)

Needle size in 1/100 mm:

Version A: 60 - 70 Nm
Version B: 80 - 100 Nm
Version C: 110 - 140 Nm

Presser foot clearance: 7 - 13 mm
Clearance width: 245 mm
Clearance height: 98 mm

Max. stitch length:

1122 Version A and B: 4 mm
1122 and 1122-720/02 Version A, B and C: 5 mm
1122-G and 1122-G-720/02 Version B and C: 7 mm

Max. speed:

1122 Version A and B: 3500 spm
1122 Version C and 1122-G: 3000 spm
1122-720/02 and 1122-G-720/02: 3000 spm

Motor data: see motor specification plate

Noise data 1122 and 1122-720/02:

Emission sound level at workplace

at a speed of 2400 spm: $L_{pa} = 80.0 \text{ dB(A)}$ ■
(Noise measurement in accordance with DIN 45 635-48-B-1, ISO 11204, ISO 3744, ISO 4871)

Noise data 1122-G and 1122-G-720/02:

Sound transmission level at a speed of 2400 spm: $L_{pa} = 93.5 \text{ dB(A)}$ ■
(Noise measurement in accordance with DIN 45 635-48-B-1, ISO 11204, ISO 3744, ISO 4871)

Sewing head dimensions:

Length: approx. 490 mm
Width: approx. 210 mm
Height: approx. 330 mm

Net weight of sewing head: approx. 44.5 kg

Gross weight of sewing head (with packaging): approx. 53,0 kilos

Packaging dimensions (sewing head only):

L x W x H: approx. 635 x 295 x 608 mm

▲ Subject to alterations

■ $K_{pA} = 2,5 \text{ dB}$

3.02 Versions and subclasses

Versions

Version A: for sewing fine materials

Version B: for sewing medium-weight materials

Version C: for sewing medium-heavy materials

Attachments:

Subclass -900/93: Thread trimmer

Subclass -909/93: Thread wiper

Subclass -911/93: Backtacking device

4 Disposal of machine

- The proper disposal of the machine is the responsibility of the customer.
- The materials used in the machines are steel, aluminium, brass and various plastics. The electrical equipment consists of plastics and copper.
- The machine is to be disposed of in accordance with the locally valid environmental protection regulations. If necessary, a specialist is to be commissioned.



Special care is to be taken that parts soiled with lubricants are separately disposed of in accordance with the locally valid pollution control regulations!

5 Transport, packaging and storage

5.01 Transport to the customer's premises

The machines are delivered completely packed.

5.02 Transport within the customer's premises

The manufacturer bears no liability for transport within the customer's premises or to the individual locations of use. Make sure that the machines are always transported upright.

5.03 Disposal of the packaging

The packaging of these machines consists of paper, cardboard and VCE fiber. The proper disposal of the packaging is the responsibility of the customer.

5.04 Storage

The machine can be stored for up to 6 months if not in use. During this time it should be protected from dust and moisture.

For longer storage the individual parts of the machine, especially the moving parts, must be protected from corrosion, e.g. by a film of oil.

Explanation of the symbols

6 Explanation of the symbols

In the following section of this Instruction Manual, certain tasks or important pieces of information are accentuated by symbols.

The symbols used have the following meanings:



Note, information



Cleaning, care



Lubrication, greasing

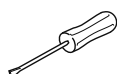

Servicing, repairing, adjustment, maintenance
(only to be carried out by specialist personnel)

7 Controls

7.01 On/off switch

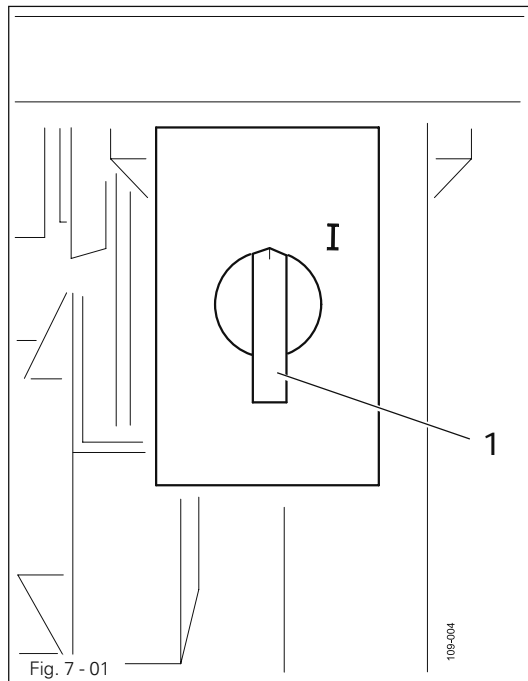

- Switch the machine on or off by turning main switch 1.



The switch in the illustration can be found on machines with Quick motors. When other motors are used, the switch may not look the same.

7.02 Pedal

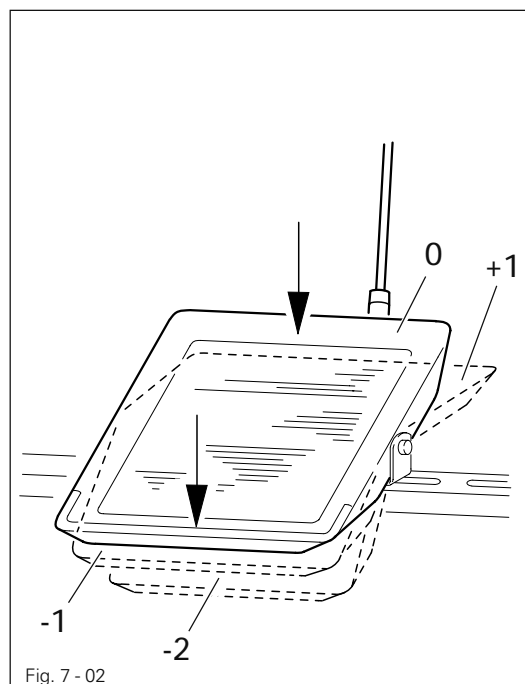

- 0 = Machine stop
- +1 = Sew
- 1 = Raise presser foot (for machines with -910/93)
- 2 = Trim thread (for machines with -900/93)



Other pedal functions can be found in the Motor Instruction Manual.

7.03 Lever for lifting the presser foot

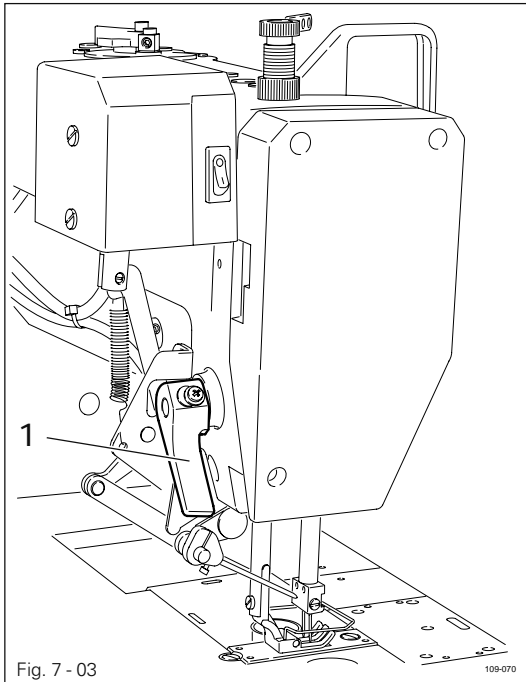

- The presser foot is raised by turning lever 1.

7.04 Knee lever

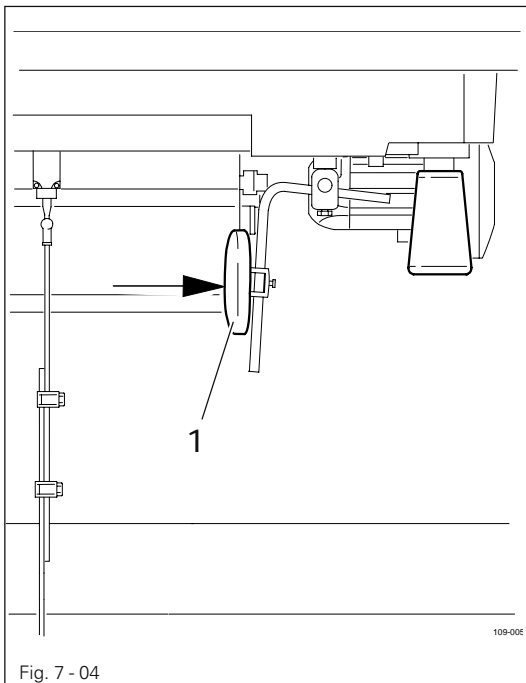

- By pressing the knee lever 1 in the direction of the arrow, the presser foot is raised.

7.05 Key on the machine head (only on machines with backtacking device -911/93)

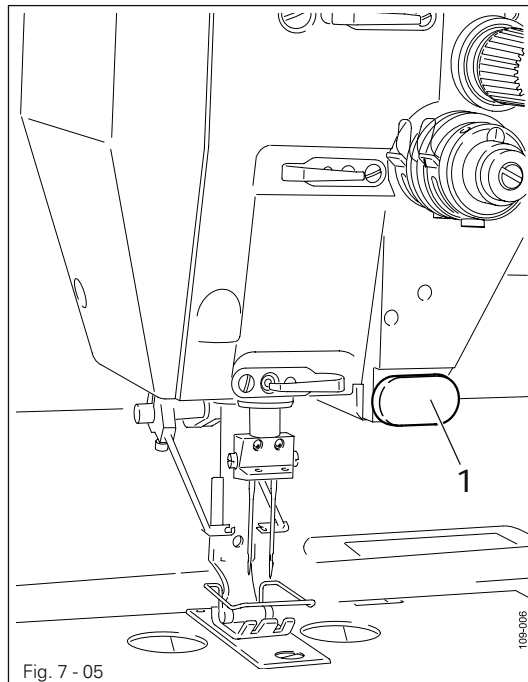

- If key 1 is pressed during the sewing operation, the machine switches to reverse sewing.

7.06 Reverse feed key

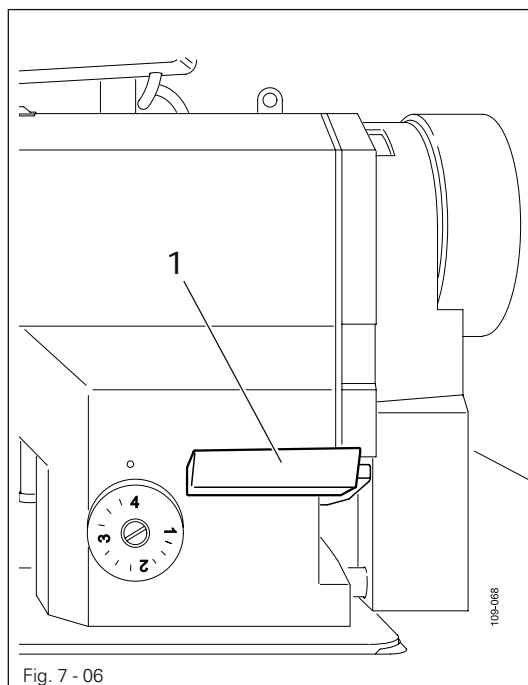

- If key 1 is pressed during the sewing operation, the machine switches to reverse sewing.

7.07 Stitch length adjustment wheel

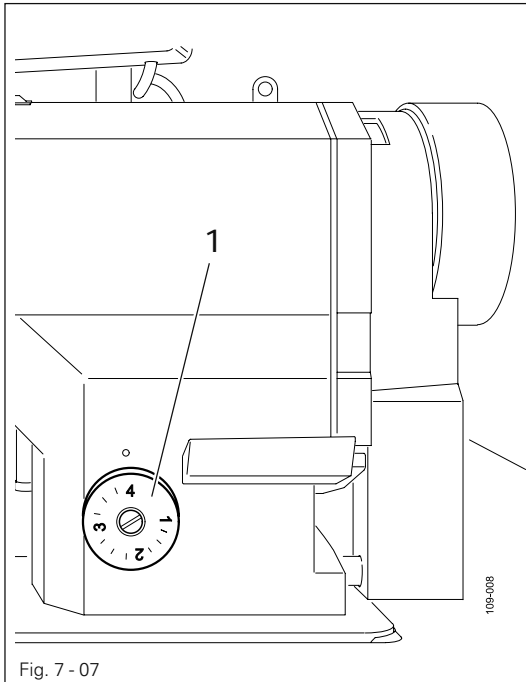

- Set the required stitch length by turning adjustment wheel 1.

7.08 Switching needles (only on machines with disengagable needles -720/02)

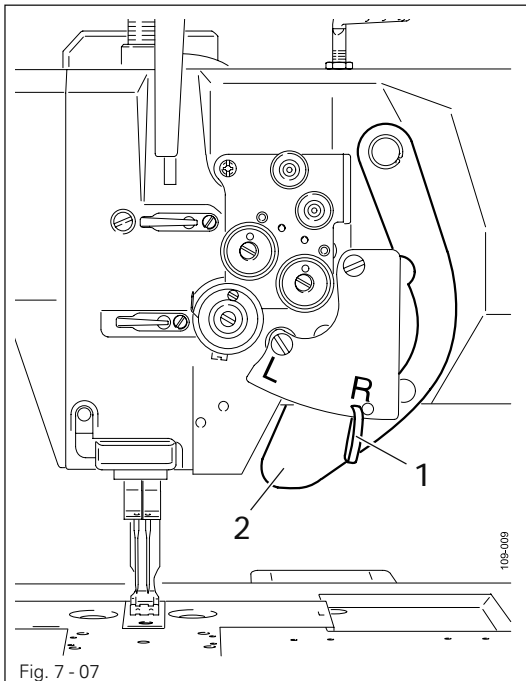

- When lever 1 is adjusted, the desired needle bar is disengaged.

Position "R" = right needle off
Position "L" = left needle off

- To release the lock on the needle bar, press key 2.



Before operating lever 1 or key 2, we recommend stopping the machine and raising the take-up lever.



When sewing with one needle bar disengaged, the maximum speed should not exceed 1000 spm.

7.09

Switch for the thread wiper (only on machines with thread wiper -909/93)

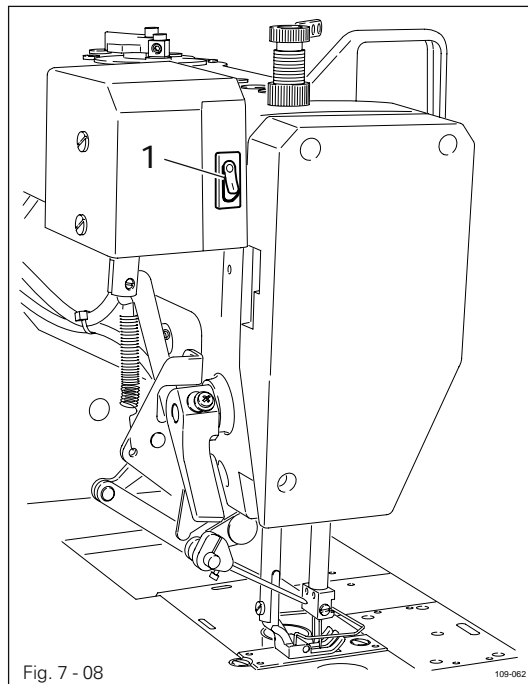

- The thread wiping function is switched on or off by pressing switch **1**.

Position "0" = off

Position "I" = on

7.10 Control panel (only on machines with Quick-motor)

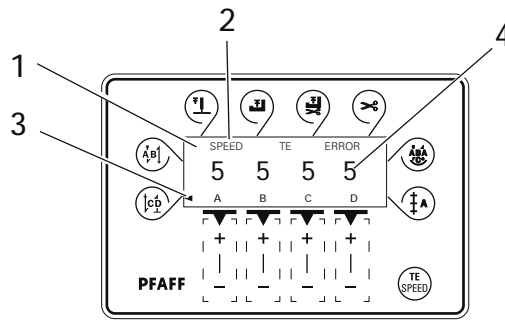

The control panel consists of display 1 and the function keys described below. The display 1 consists of a single-line alpha-numerical, 7 segment LCD display with 8 symbols. The texts 2, located above and next to the LCD display, show the respective status of the function keys and the operating status of the machine. The control panels switches on all LCD-segments and the horn automatically for a short time during the power-on phase, after which the lettering PFAFF appears on the display, until the higher-ranking control unit sends commands to the control panel.

The function keys are located around the display 1. They are foil-packed without permanent marking and without contact signal. Fixed functions are allocated to the keys, see [Chapter 7.10.02 Function keys](#).

7.10.01 Screen displays

- Activated functions are displayed with a triangular marking 3 below or next to the respective function key.
- In the sewing mode all relevant sewing data is displayed and can be changed directly, depending on the status of the machine, see also [Chapter 10 Sewing](#).
- During the parameter input the selected parameter number with the corresponding value is displayed, see [Chapter 12.08.02 Example of a parameter input](#).

7.10.02 Function keys

The function keys described below are used basically to switch machine functions on and off.

Each time a key is pressed, this must be confirmed by at least one beep tone. Irrespective of the machine mode a double beep signal is given if invalid keys are pressed or maximum values reached.

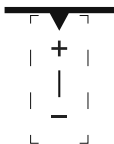

If a corresponding value has to be set for the activated function, this is carried out with the corresponding +/- key. By pressing and holding the corresponding +/- key, the relevant numerical value 4 is changed slowly to begin with. If the corresponding +/- key is held down longer, the values change more quickly.



Start backtacks

- If this key is pressed, the backtacks at the beginning of the seam (start backtacks) are switched on or off. The number of forward stitches (A) or reverse stitches (B) for the start backtacks can be changed by pressing the +/- key underneath. To convert from double backtack to single backtack set the number of stitches for the corresponding seam section at zero.



End backtacks

- If this key is pressed, the backtacks at the end of the seam (end backtacks) are switched on or off. The number of reverse stitches (C) or forward stitches (D) can be changed by pressing the +/- key underneath. To convert from double backtack to single backtack set the number of stitches for the corresponding seam section at zero.



Needle position

- If this key is pressed the "needle raised after sewing stop" function is switched on or off. When the function is switched on, the needle positions at t.d.c. after sewing stops.



Foot position after stop

- If this key is pressed the "foot raised after sewing stop" function is switched on or off. When the function is switched on, the presser foot is raised after sewing stops.



Foot position after trimming

- If this key is pressed the "foot raised after thread trimming" function is switched on or off. When the function is switched on, the presser foot is raised after thread trimming.



Thread trimmer

- If this key is pressed the thread trimming function is switched on or off.



Darning program

- If this key is pressed the darning program function is switched on or off. The counted seam function is switched off automatically.



Counted seam

- If this key is pressed the counted seam function is switched on or off. The darning program function is switched off automatically.



TE/Speed

- If this key is pressed once the speed limit for the sewing mode is activated.
- If this key is pressed twice (within 5 seconds) the machine changes from sewing to input mode.

8 Installation and commissioning



The machine must only be installed and commissioned by qualified personnel!
All relevant safety regulations must be strictly adhered to!
If the machine is delivered without a table, be sure to use a stand and table top that can hold the weight of the machine with its motor.
It is very important to ensure that the stand of the machine is firm and steady, also during sewing.

8.01 Installation

The site where the machine is installed must be provided with suitable connections for electric current.

It must be ensured that the standing surface of the machine site is firm and horizontal, and that sufficient lighting is provided for.



For packing and transportation reasons the table top is in the lowered position.
The table height is adjusted as described below.

8.01.01 Adjusting the table height

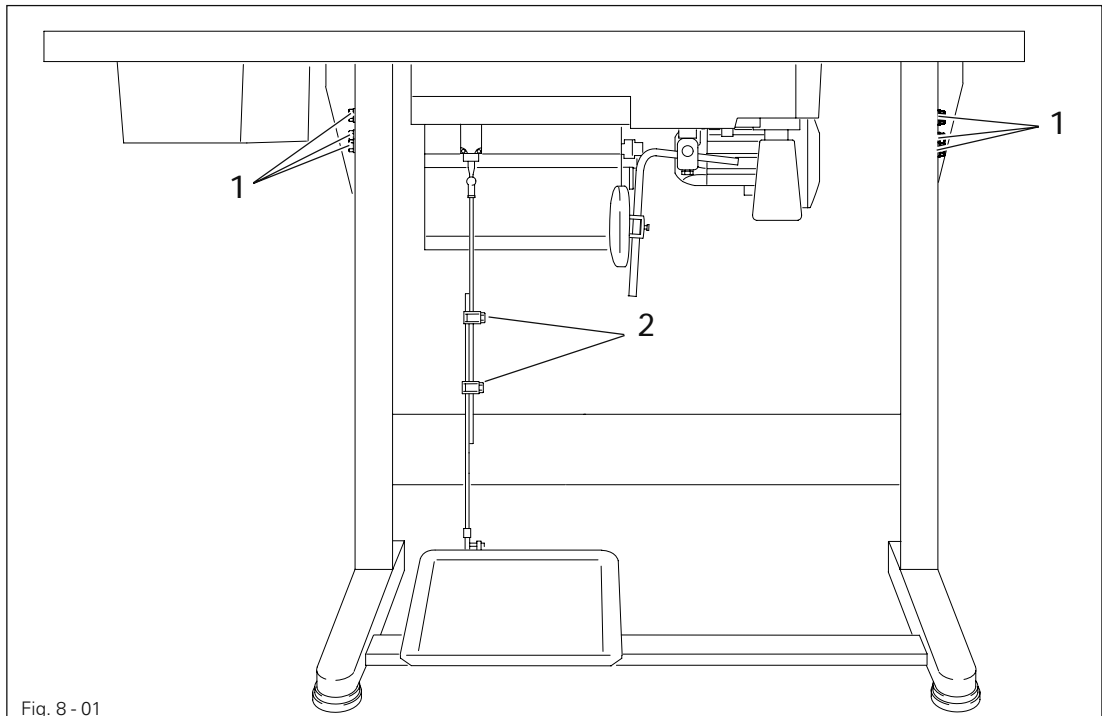

- Loosen screws 1 and 2 and set the table height as required.
- Firmly tighten screw 1.
- Set the required pedal position and tighten screw 2.

8.01.02 Assembling the oil pan

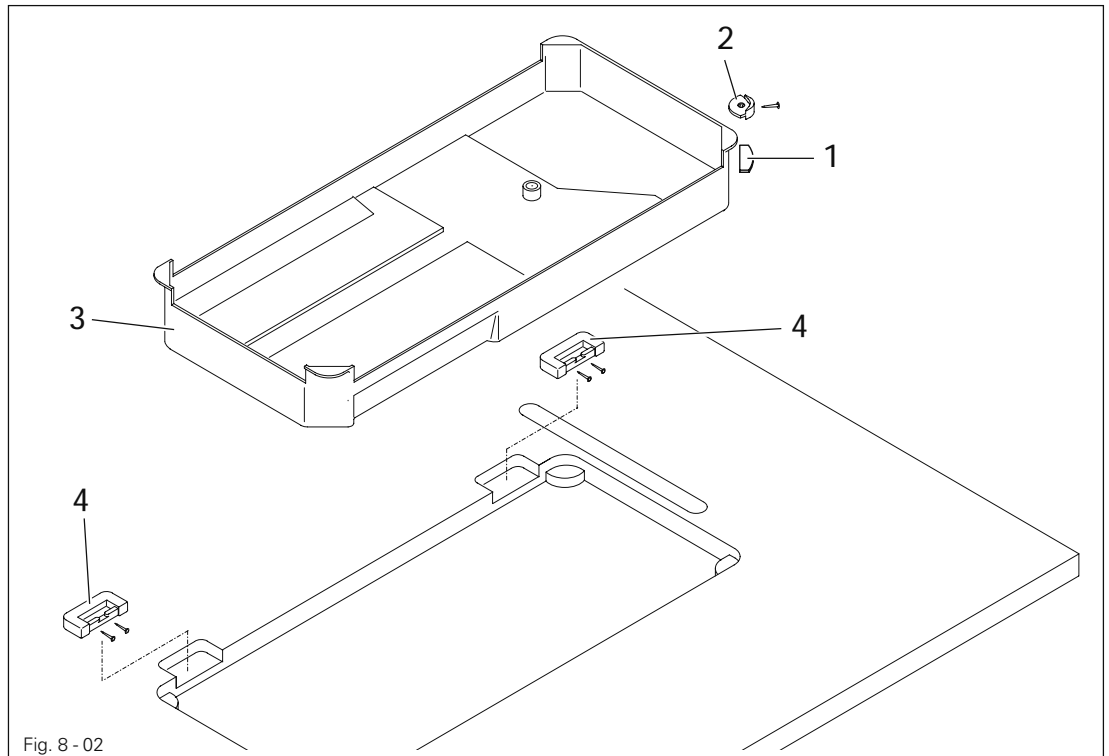

- Insert rubber support 1.
- Insert bearing bushes 2 and fasten with nails.
- Place oil pan 3 in the table-top opening.
- Insert rubber pad 4 and fasten with nails.

8.01.03 Mounting the sewing head

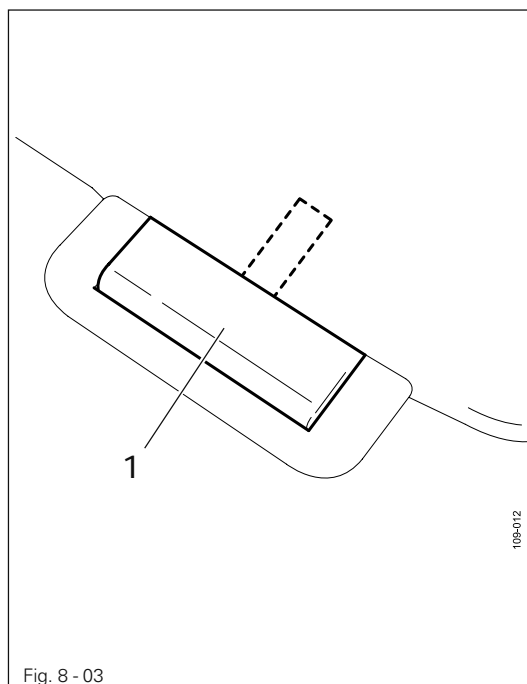

- Place both hinges 1 in the appropriate holes in the bedplate of the sewing head and screw tight.
- Place the sewing head with hinges 1 into the back rubber pads.

Installation and commissioning

8.01.04 Assembling the motor (only on machines with Quick-motor)

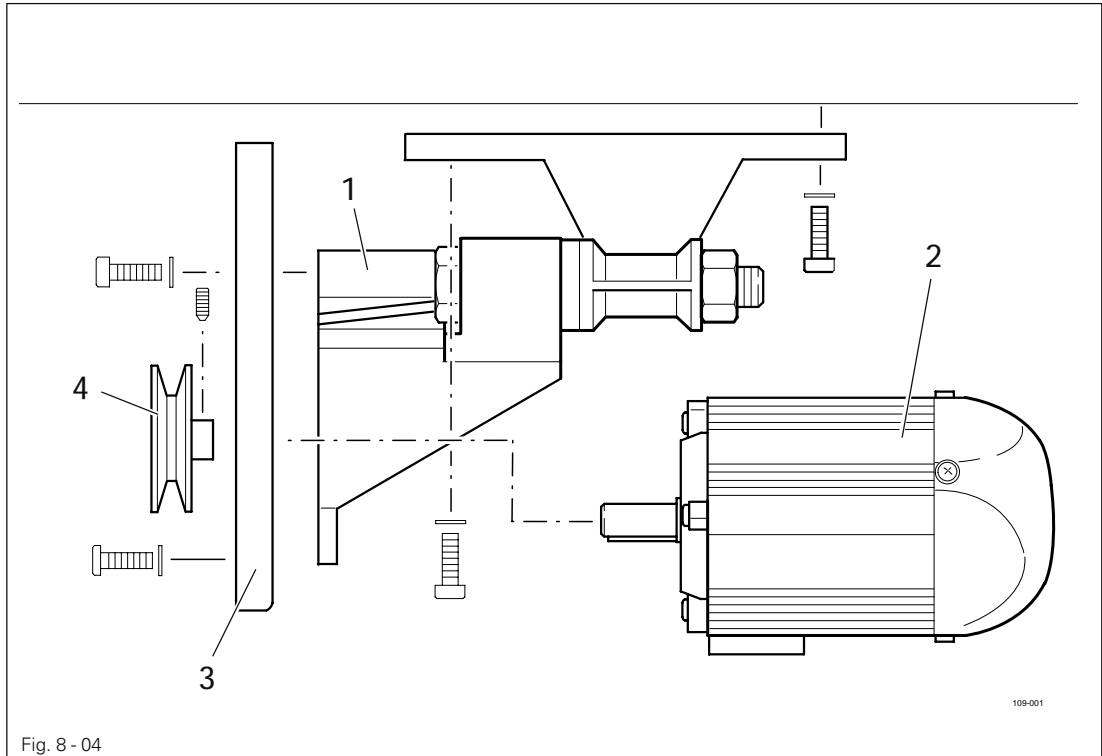

- Assemble motor mounting 1, motor 2, belt guard support 3 and belt pulley 4 as shown in Fig. 8-04.

8.01.05 Tightening the V-belt

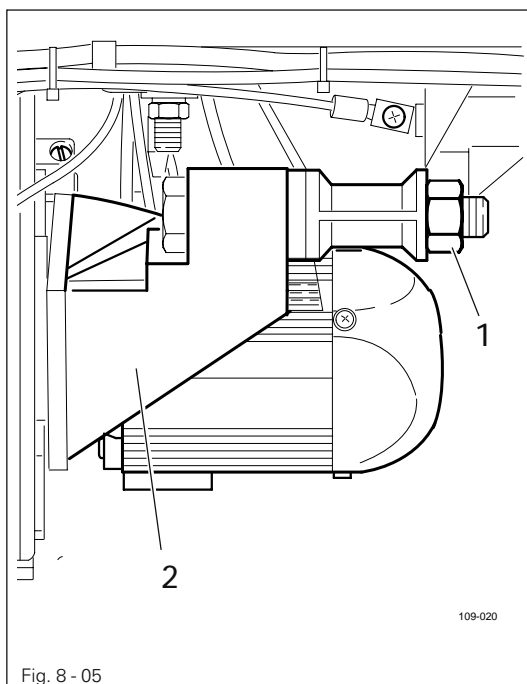

- Fit the V-belt.
- Loosen nut 1 and tighten the V-belt by turning motor mounting 2.
- Tighten nut 1.

8.01.06 Mounting the bottom V-belt guard

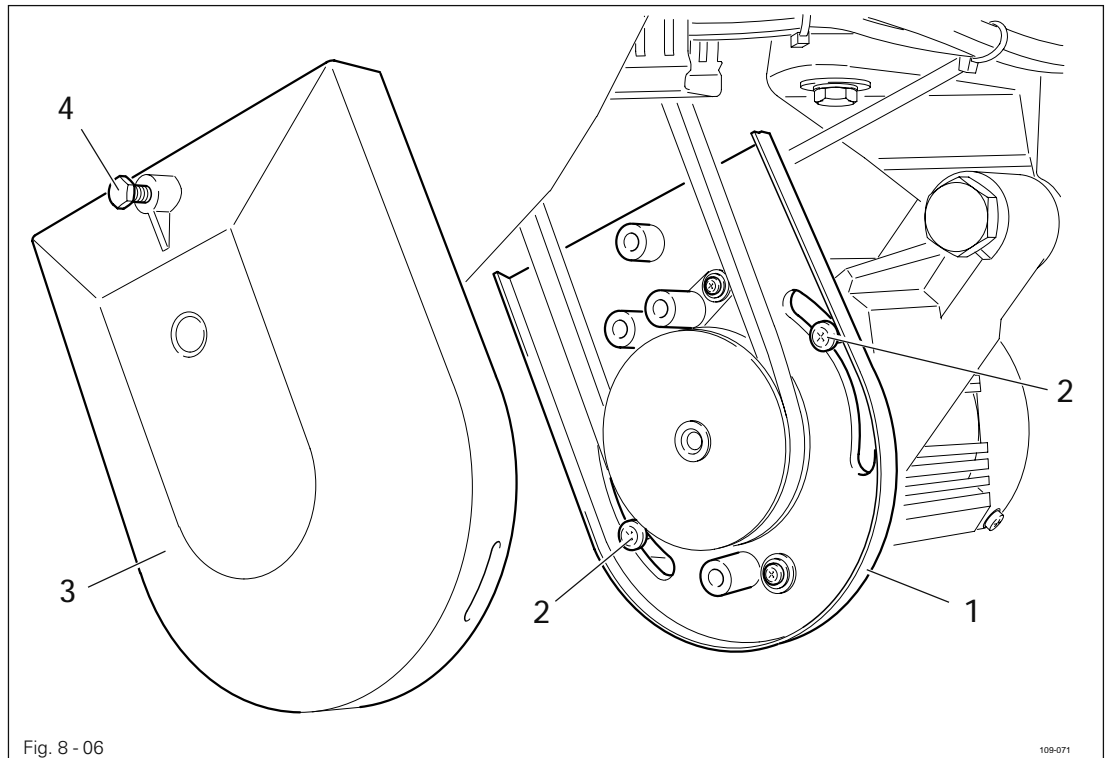

- Loosen screws 2 and adjust belt guard support 1 so that the motor pulley and V-belt run freely.
- Tighten screws 2.
- Fasten belt guard 3 with screw 4.



Fig. 8-06 shows a Quick-motor. If a different motor is used, follow the instructions of the Motor Instruction Manual.

Installation and commissioning

8.01.07 Mounting the top V-belt guard

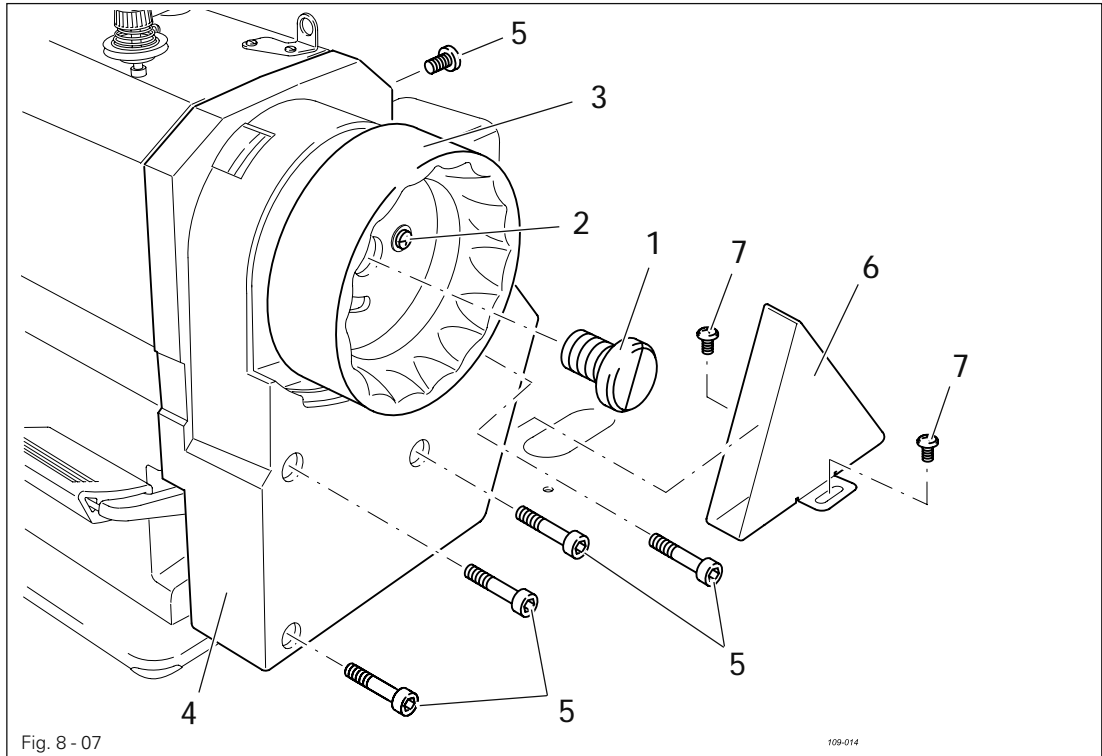

- Take out screws 1 and 2 and remove balance wheel cover 3.
- Fasten belt guard 4 with screws 5.
- Fasten belt guard 6 with screws 7.
- Reattach cover 3 with screws 1 and 2.

8.01.08 Fitting the reel stand

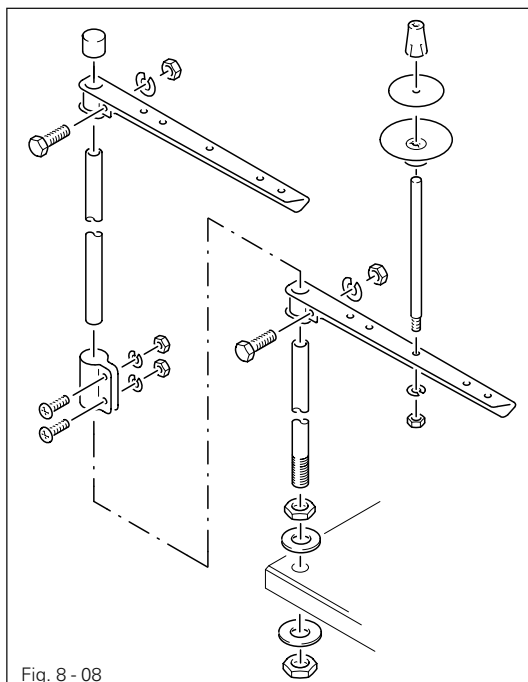

- Fit the reel stand as shown in Fig. 8 - 08.
- Afterwards insert the stand in the hole in the table top and secure it with nuts provided.

8.01.09 Connecting the plug-in connections and earth cables

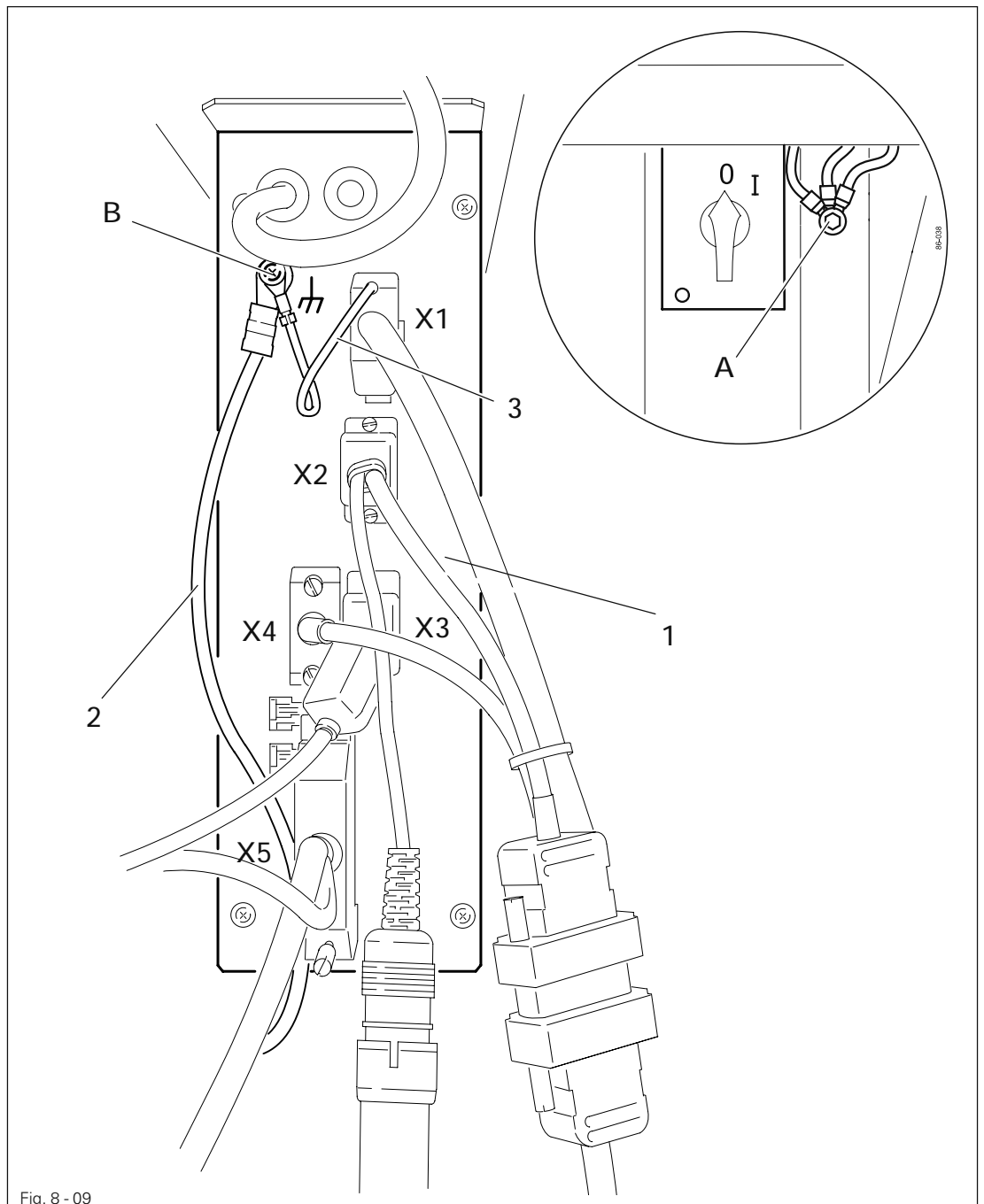

- Connect the plug connections leading off the machine to adapter X5.
- Connect all plugs as labelled to the control box 1.
- Screw the earth cable from the sewing head and the main switch to earth point A.
- Connect earth point A to earth point B with earth cable 2.
- Screw the earth cable 3 from the motor to earth point B.

8.02

Commissioning



Before commissioning the machine, clean it thoroughly, fill the oil pan with oil and adjust the oil level, see **Chapter 10 Care and Maintenance!**

- Examine the machine, in particular the electric cables, for any damage.



Have qualified personnel check whether the machine can be operated with the available voltage and whether it is connected properly. If there are any irregularities do **not** operate the machine!



The machine may only be connected to an earthed socket!



When commissioning the machine or after a long period of non-operation, operate the machine with **max. 2000 spm** for the first 10 minutes! Danger of damage to the machine!

- When the machine is running, the balance wheel must turn towards the operator. If this is not the case, have the motor adjusted by qualified personnel, see the motor operating instructions.

8.02.01

Switching on the machine and executing the pulley function

(only on machines with Quick motor)

- Switch the machine on as described in **Chapter 7.01 Main switch**.

When the machine is switched on for the first time, the text "pulley" appears on the display

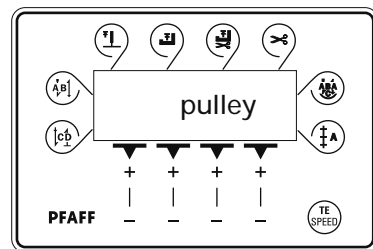

- Operate the pedal briefly (sewing).

The machine begins to run slowly, ascertains the transmission ratio between motor and machine and stops running after about 2 revolutions.



If the pulley function does not appear after the machine has been switched on for the first time, or if the machine has an undefined position, a master reset must be carried out, see **Chapter 12.10 Cold start** in the adjustment manual.

8.02.02 Basic position of the machine drive unit (only on machines with Quick motor)

2 x 

- Switch on the machine.
- Press the TE/speed key twice to select the input mode.

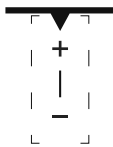
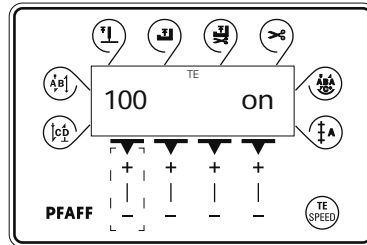

- Select parameter "798" by pressing the corresponding +/- key, and select service level C, see Chapter 12.08.01 Selecting the user level in the adjustment manual.

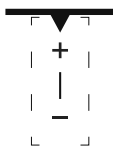
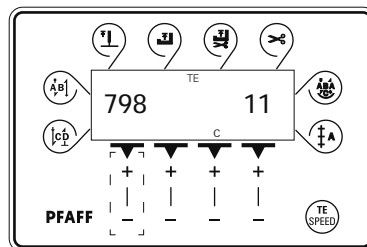

- Select parameter "799" by pressing the corresponding +/- key (selecting the machine class).

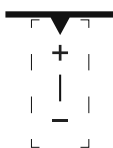
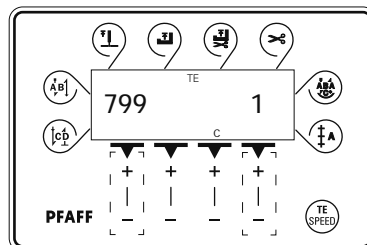

- By pressing the corresponding +/- key, set the value for the parameter at "1".
- By pressing the corresponding +/- key, select parameter "700".

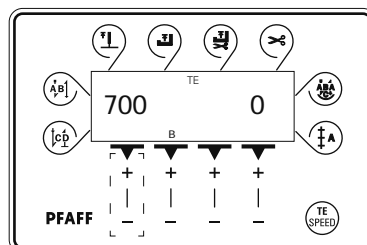

- Sew one stitch by operating the pedal.
- Turn the balance wheel in the sewing direction until the needle point is level with the top edge of the needle plate.



- Conclude the sewing motor adjustment by pressing the TE/speed key.

8.03 Table top cutout.

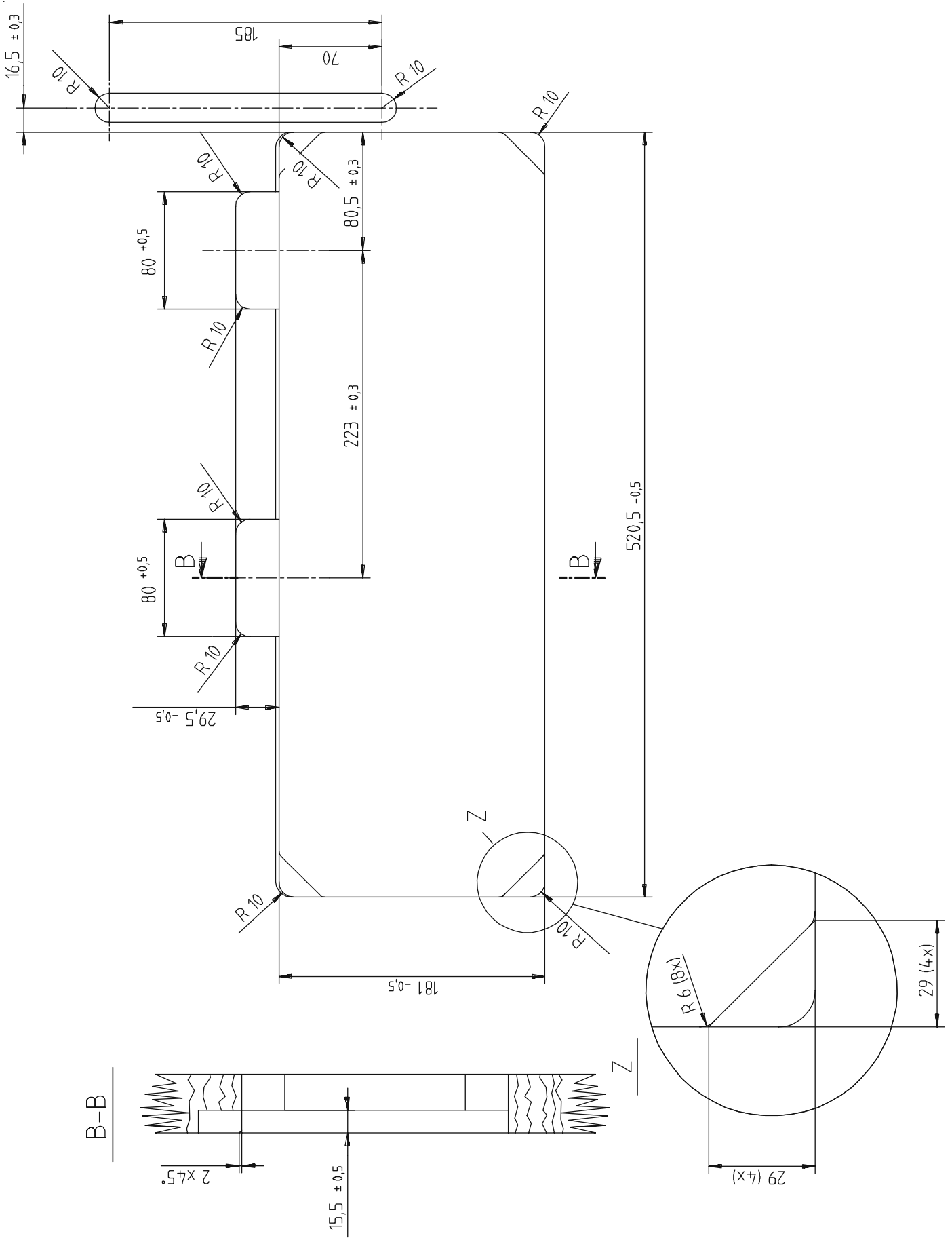

8.04

Mounting the table top

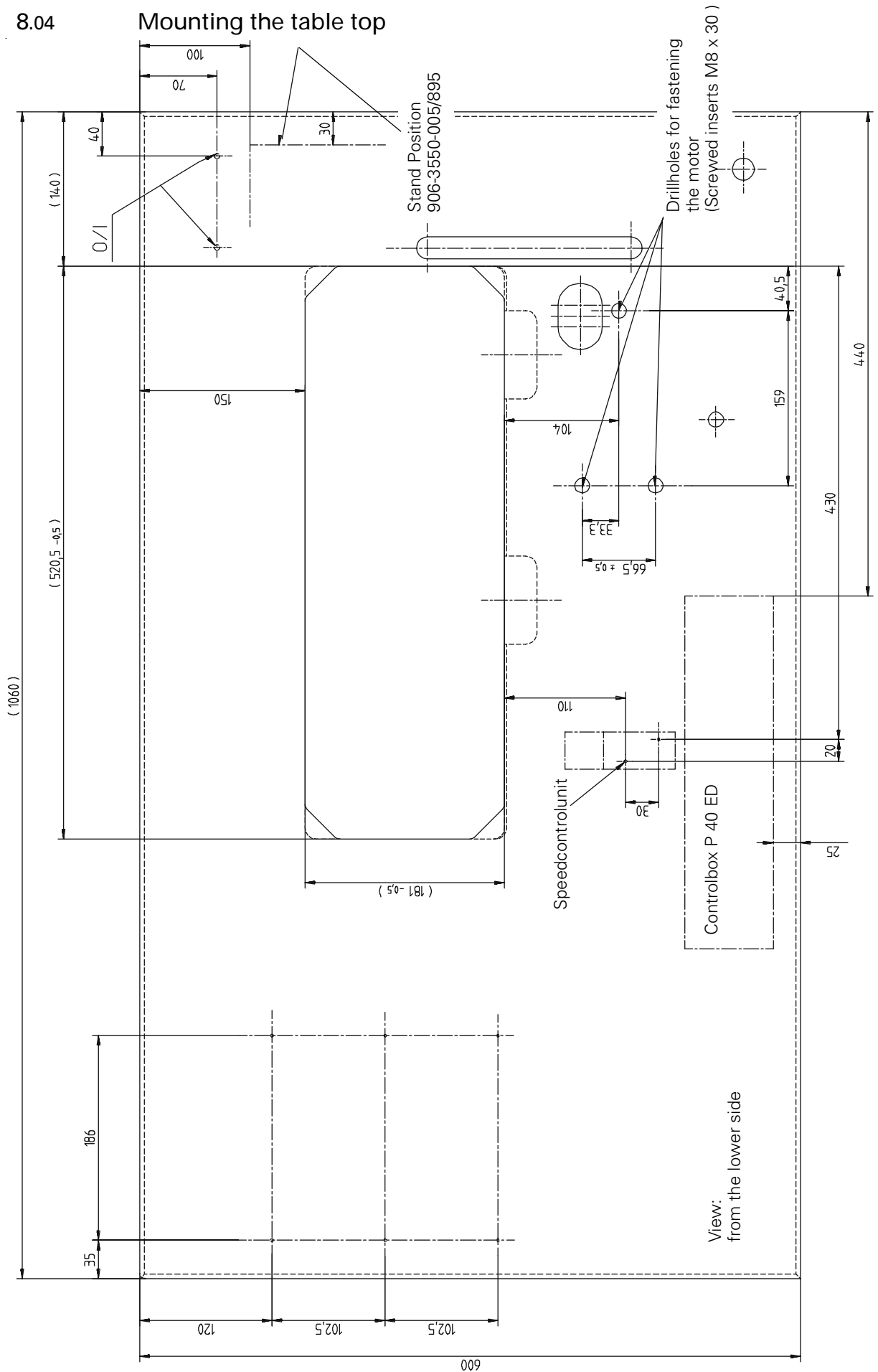

9

Setting up



All instructions and regulations in this instruction manual must be observed. Special attention must be given to all safety regulations!



All setting-up work must only be done by personnel with the necessary training. For all setting-up work the machine must be isolated from its power supply by turning off the on/off switch or removing the machine plug from the electric power socket!

9.01

Inserting the needle

On machines without needle switch-off

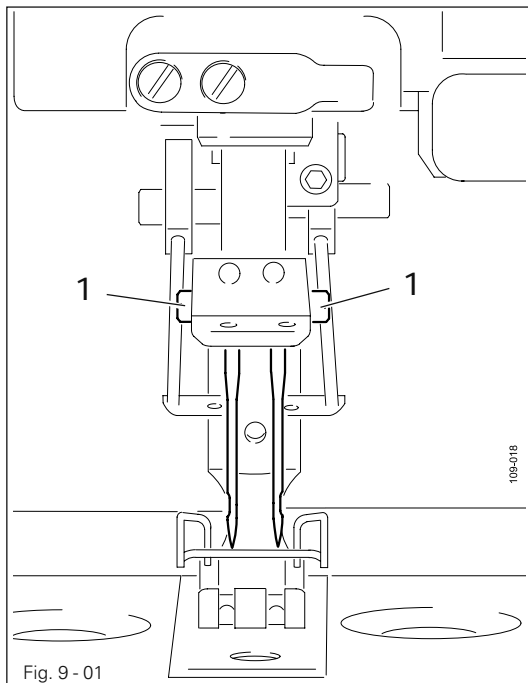

Fig. 9-01

On machines with needle switch-off -720/02

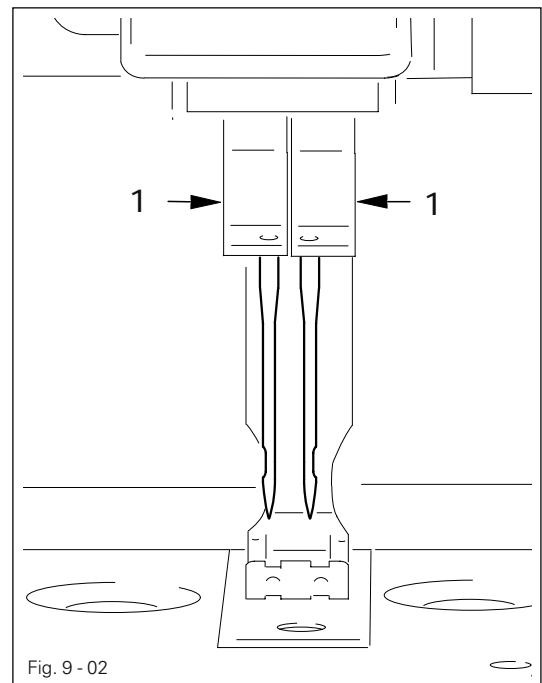

Fig. 9-02



Switch off the machine!
Danger of injury if the machine is started accidentally!



Only use needles from the system intended for the machine, see Chapter 3 Specifications.

- Raise the needle bar and loosen screws 1.
- Insert the needle as far as possible (the long groove of the left needle must be pointing to the right and the long groove of the right needle to the left).
- Tighten screws 1.



The selection of the needles depends on the machine version and the threads and material being used, see Chapter 3 Specifications.

9.02 Winding the bobbin thread

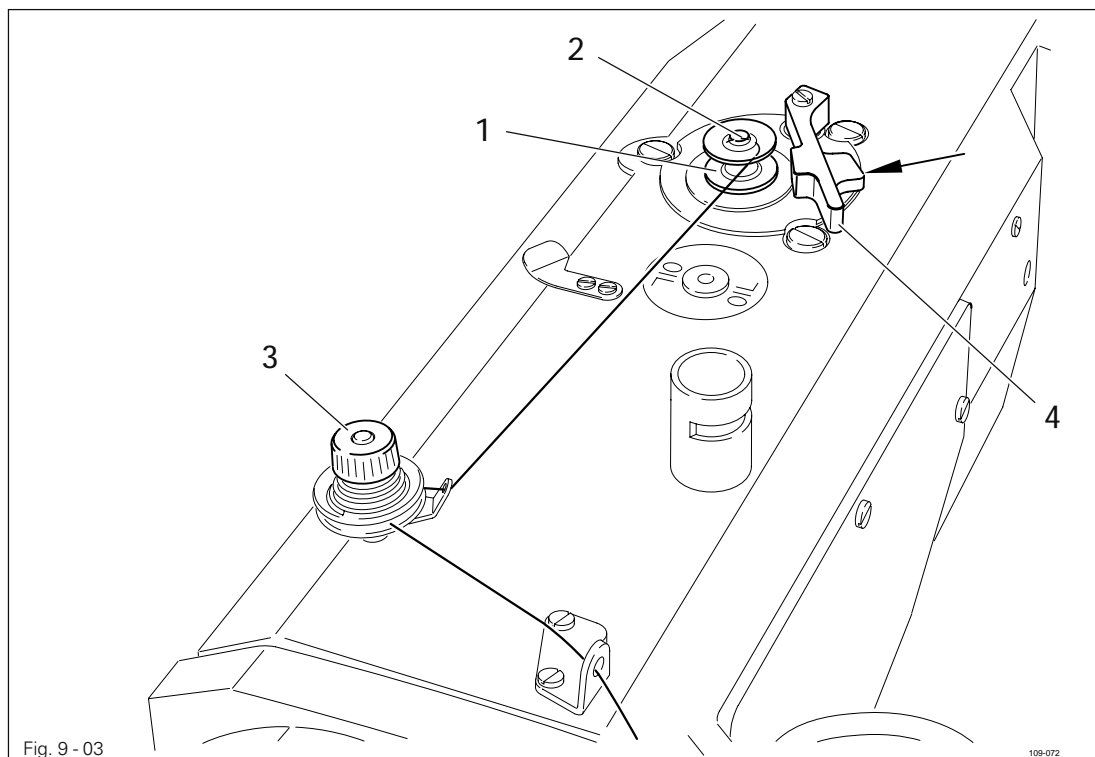

- Place the empty bobbin 1 on bobbin winder spindle 2.
- Thread the thread as shown in Fig. 9-03 and wind it around the bobbin a few times in a clockwise direction.
- Adjust the thread tension by turning knurled screw 3.
- Push lever 4 in the direction of the arrow until it locks into place.



The bobbin is filled during sewing.

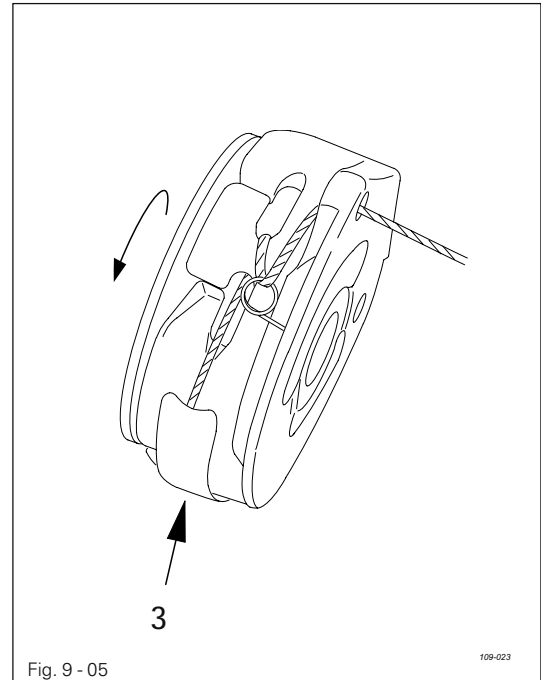
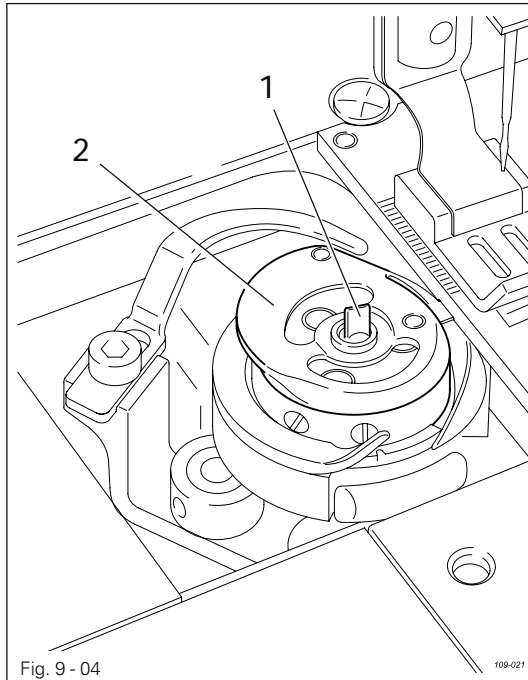

Switch off the machine!

Danger of injury if the machine is started accidentally!

Removing the bobbin case

- Raise the take-up lever to its top position.
- Open the cover of the hook compartment, raise latch 1 and remove bobbin case 2.

Threading the bobbin case

- Thread the bobbin as shown in Fig. 9-05.
- When the thread is drawn, the bobbin must turn in the direction of the arrow.
- With screw 3 adjust the bobbin thread tension so that the material does not pucker and the thread does not break.

Inserting the bobbin case

- Insert the bobbin case 2 in such a way, that you can feel it click into place.
- Press down latch 1 and close the cover of the hook compartment.



Do not operate the machine with the cover of the hook compartment open!

Danger of injury from the rotating hook!

9.04 Changing the bobbin (on machines with drop-in hook)

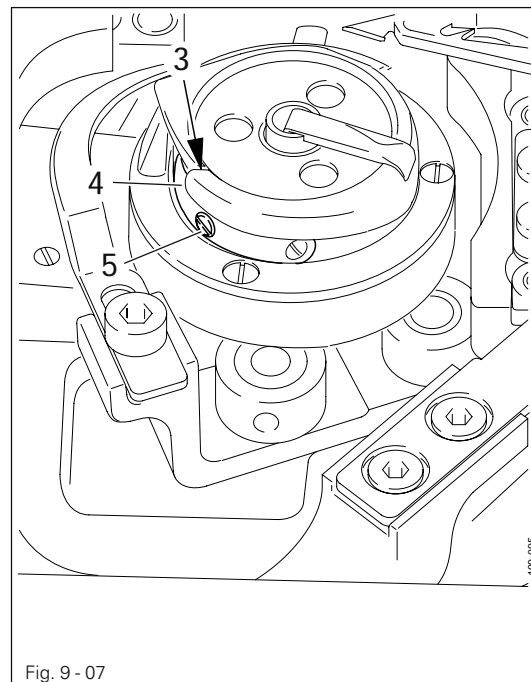
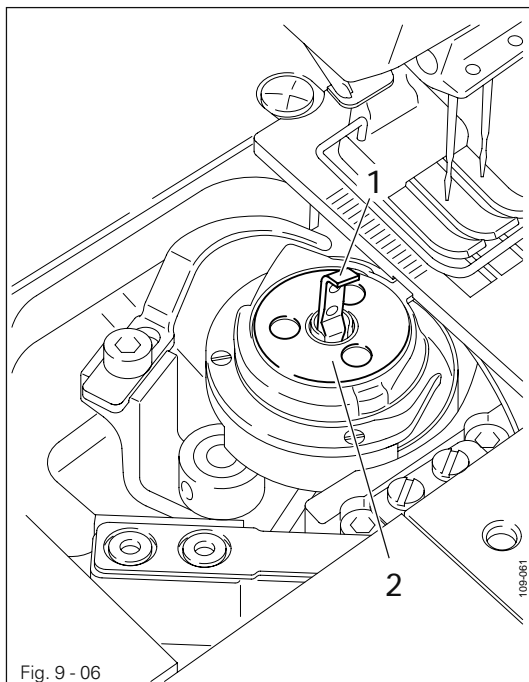

Switch off the machine!
 Danger of injury if the machine is started accidentally!

- Raise the take-up lever to its top position.
- Open the cover of the hook compartment, raise latch 1 and remove empty bobbin 2.
- Insert the full bobbin and press down latch 1 again.
- Guide the bobbin thread under spring 4 through slot 3.
- By turning screw 5 adjust the bobbin thread tension so that the material does not pucker and the thread does not break.
- Close the cover of the hook compartment.



Do not operate the machine with the cover of the hook compartment open!
 Danger of injury from the rotating hook!

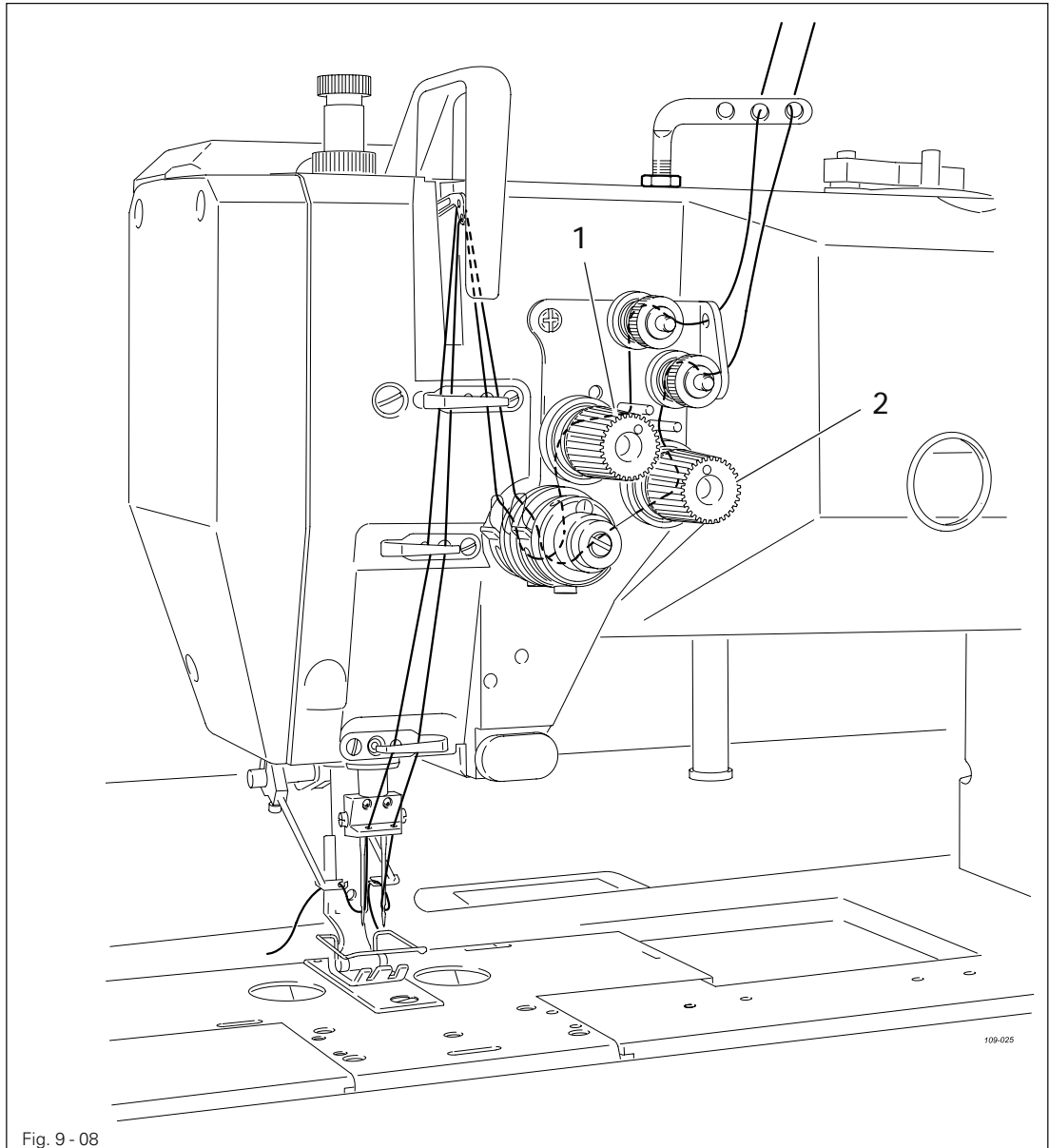

Switch off the machine!
Danger of injury if the machine is started accidentally!

- Thread the needle thread as shown in Fig. 9 - 08.
- Regulate the needle-thread tension by turning milled screw 1 or 2.

9.06 Adjusting the stitch length

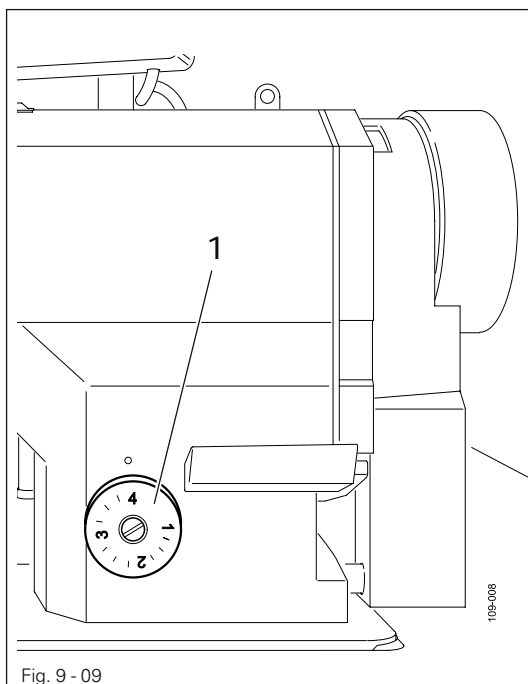

- Set the desired stitch length with adjustment wheel 1.

Fig. 9 - 09

9.07 Entering start and end backtacks (only on machines with Quick motor)

- Switch on the machine.

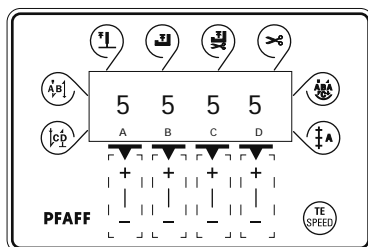

- If necessary switch off the "darning seam" or "counted seam" function.
- Select the values for the number of stitches by pressing the corresponding +/- keys:
 - A = number of forward stitches for the start backtacks
 - B = number of reverse stitches for the start backtacks
 - C = number of reverse stitches for the end backtacks
 - D = number of forward stitches for the end backtacks

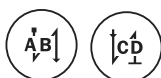

- Switch on the corresponding functions by pressing the start backtacks and /or end backtacks key (arrow appears opposite the corresponding function key).

9.08 Setting the stitch counting function for monitoring the bobbin thread (only on machines with Quick motor)

- Switch on the machine.

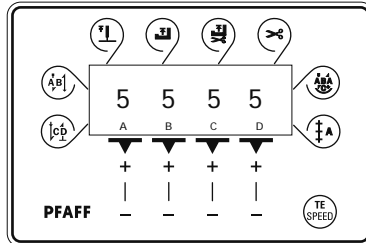

- 2 x  ● Press the TE/speed key twice to select the input mode.

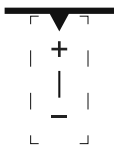
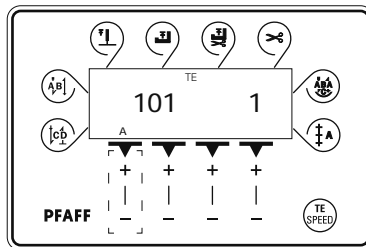

- Select parameter "798" and call up mechanics level B, see Chapter 12.08.01 Selecting the user level in the Adjustment Manual.

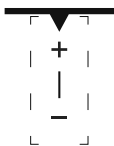

- Select parameter "760" by pressing the corresponding +/- key."

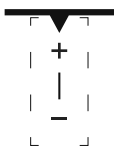
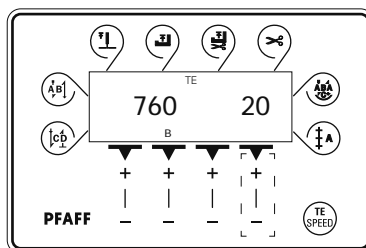

- By pressing the corresponding +/- key, set the number of stitches which can be sewn with one bobbin.
The selected value is multiplied by 200 and this gives the number of stitches.
Example display text 20 x 200 = 4000 stitches.

-  ● Store the input by concluding the parameter input.

10 Care and maintenance

10.01 Maintenance intervals

Clean the entire machine	once a week
Clean the hook compartment	once a day, or more often if in continuous use
Oil the machine	once a week
Oil the hook race	when commissioning the machine and after long downtimes
Oil the head parts (felt)	when commissioning the machine and after long downtimes



During all cleaning work the machine must be disconnected from the power supply by switching off the main switch or pulling out the plug!
Danger of injury if the machine is started accidentally!

10.02 Cleaning the machine

The cleaning cycle required for the machine depends on following factors:

- Single or several shift operation
- Amount of dust resulting from the workpiece

It is therefore only possible to stipulate the best possible cleaning instructions for each individual case.



For all cleaning work the machine must be disconnected from the mains by switching off the on/off switch or by removing the mains plug!
Danger of injury if the machine suddenly starts up .



To avoid breakdowns, the following cleaning work is recommended for single shift operation:

- Clean hook compartment and needle area of sewing head several times daily.
- Clean the entire machine at least once a week.

10.03 Cleaning the hook compartment

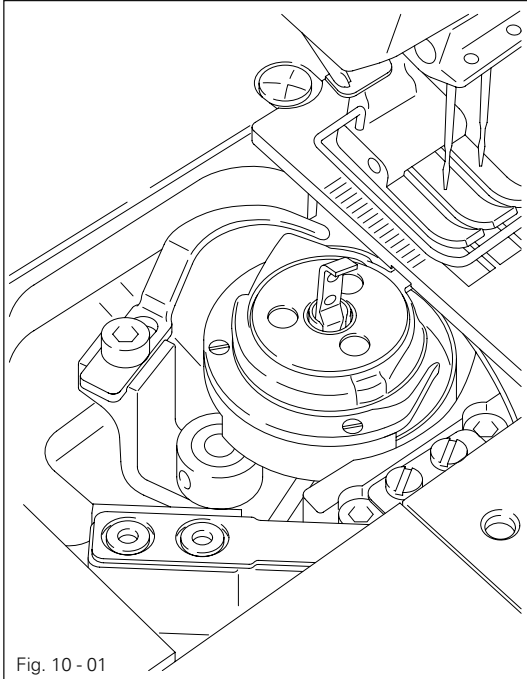

Fig. 10 - 01

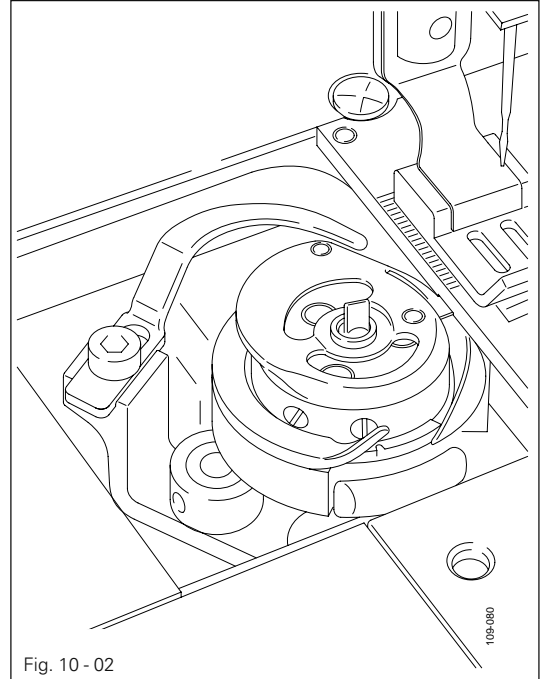

Fig. 10 - 02



Switch off the machine!

Danger of injury if the machine is started accidentally!

- Open the hook compartment covers.
- Remove the bobbins or bobbin cases.
- Clean the hook and hook compartment.
- Insert the bobbins or bobbin cases and close the hook compartment covers.

10.04 Oiling the machine

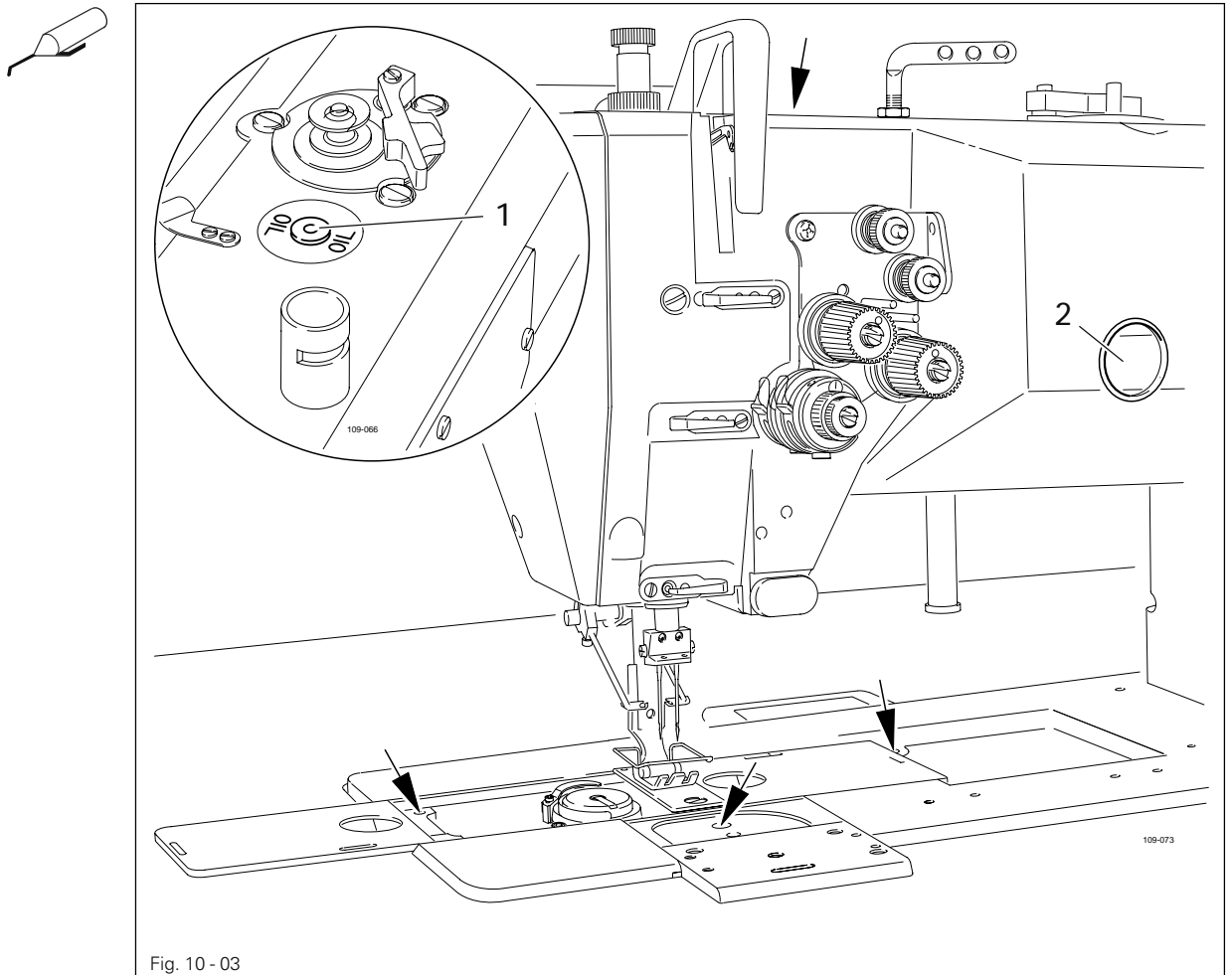

Switch off the machine!
 Danger of injury if the machine is started accidentally!

- When required fill in oil through hole 1 to the top marking of gauge glass 2.
- In addition apply a few drops of oil once a week to the spots marked, see arrows in Fig. 10-03.



Only use oil with a mean viscosity of 10.0 mm²/s at 40°C and a density of 0.847 g/cm³ at 15°C.

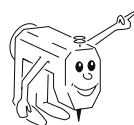

We recommend PFAFF sewing machine oil, part no. 280-1-120 105.

10.05 Oiling the hook race

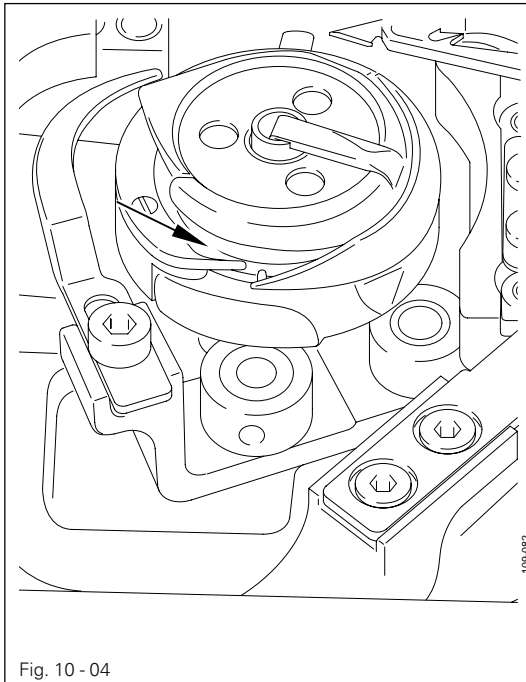

Switch off the machine!
Danger of injury if the machine is started accidentally!

- Before commissioning the machine and after long downtimes also apply a few drops of oil to the hook race, see arrow in Fig. 10-04.



Only use oil with a mean viscosity of 10.0 mm²/s at 40°C and a density of 0.847 g/cm³ at 15°C.

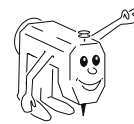

We recommend PFAFF sewing machine oil, part no. 280-1-120 105.

10.06 Oiling the head parts

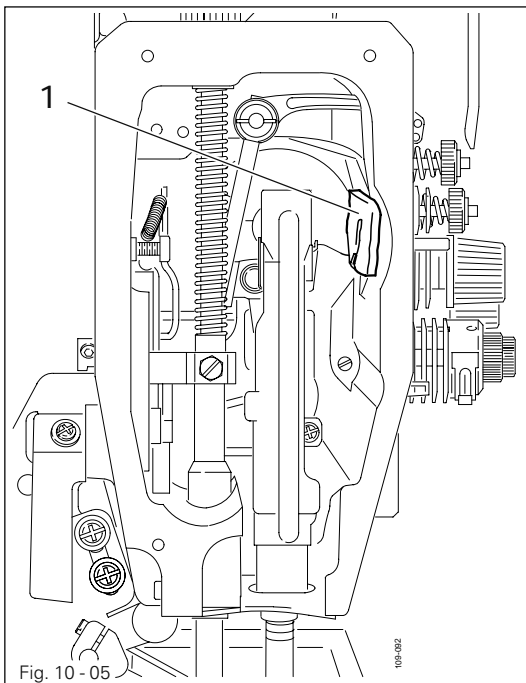

Switch off the machine!
Danger of injury if the machine is started accidentally!

- Before commissioning the machine and after long downtimes also apply a few drops of oil to felt 1.



Only use oil with a mean viscosity of 10.0 mm²/s at 40°C and a density of 0.847 g/cm³ at 15°C.

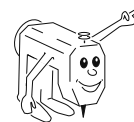

We recommend PFAFF sewing machine oil, part no. 280-1-120 105.

10.07 Oil disposal

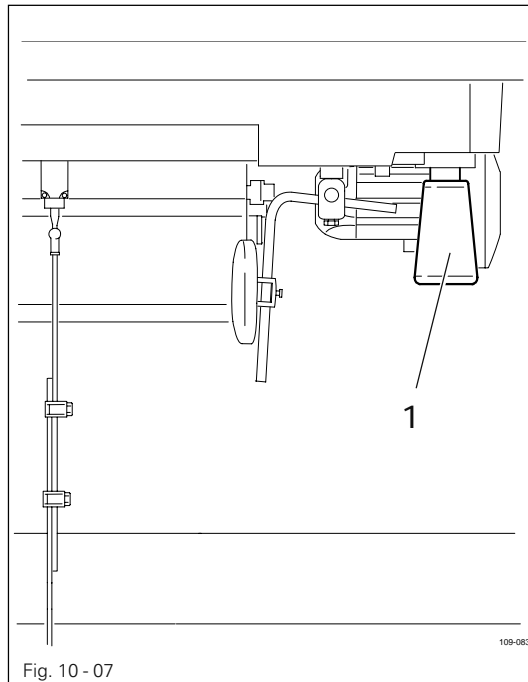

- When required, unscrew oil collector 1 and dispose of the oil in accordance with the valid local environmental regulations.



The oil must not get into the sewer system! Danger of damage to the environment!



This is a list of the most important wearing parts.

A detailed parts list for the complete machine is included with the accessories.

In case of loss, the parts list can be downloaded from the internet address www.pfaff-industrial.com/de/service/download/index.php3. As an alternative to the internet download the parts lists can also be ordered in book form under part no. 296-12-18 581.

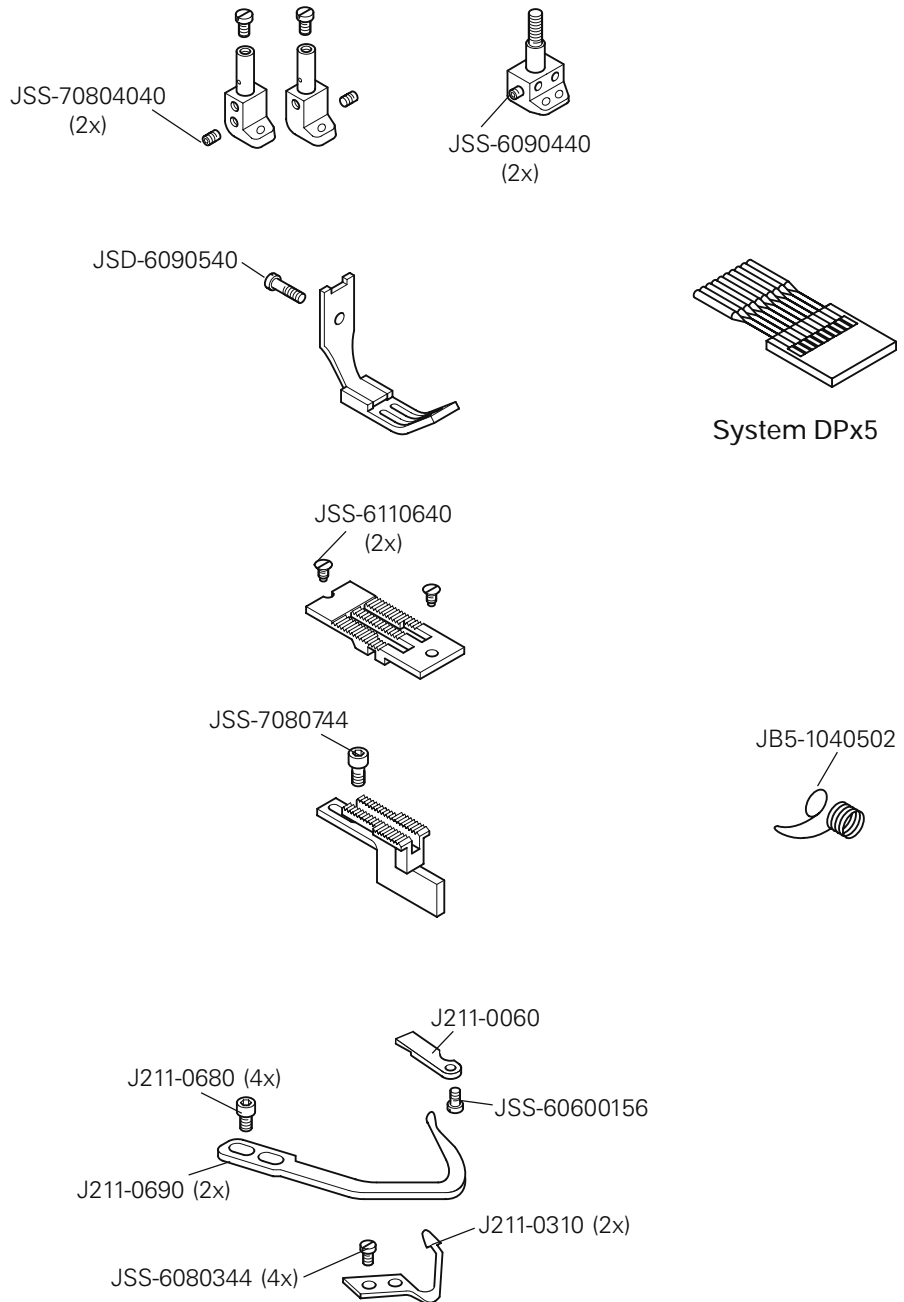

J205-2970 (1122-720 A, B, C)
 J208-0020 (1122-G-720 A, B, C)
 J213-0940 (1122-720-900 A, B, C)

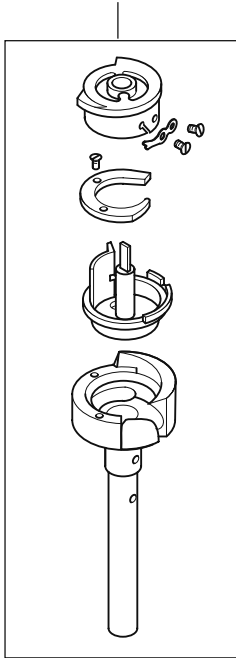

J201-2970 (1122 A, B)
 J211-0940 (1122-900 A, B, C)
 J202-2970 (1122 C)
 J203-0180 (1122-G A, B, C)

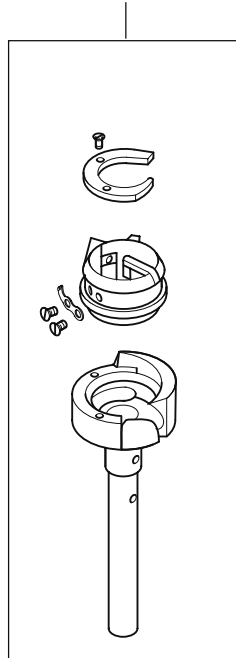

J215-0020 (1122-G-900 A, B, C)
 J221-0020 (1122-G-720-900 A, B, C)

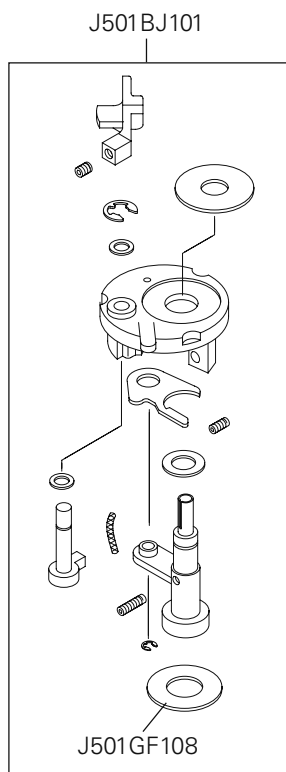
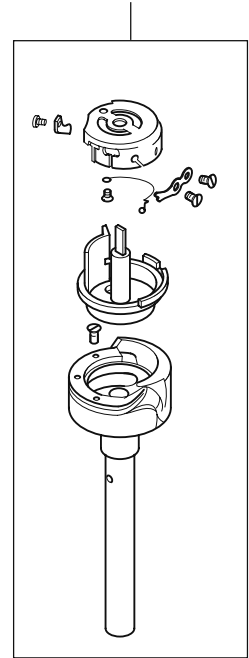

J201-1180 (1122)
 J203-0060 (1122-G)



Europäische Union
Wachstum durch Innovation – EFRE



PFAFF Industriesysteme und Maschinen AG

Hans-Geiger-Str. 12 - IG Nord
D-67661 Kaiserslautern

Phone: +49-631 200-0
Fax: +49-631 17202
E-mail: info@pfaff-industrial.com

Hotlines:

Technical service: +49-175/2243-101
Application consultancy: +49-175/2243-102
Spare-parts hotline: +49-175/2243-103