

JUKI®

High-speed, Flat-bed Coverstitch Machine

MF-7700 Series

ENGINEER'S MANUAL

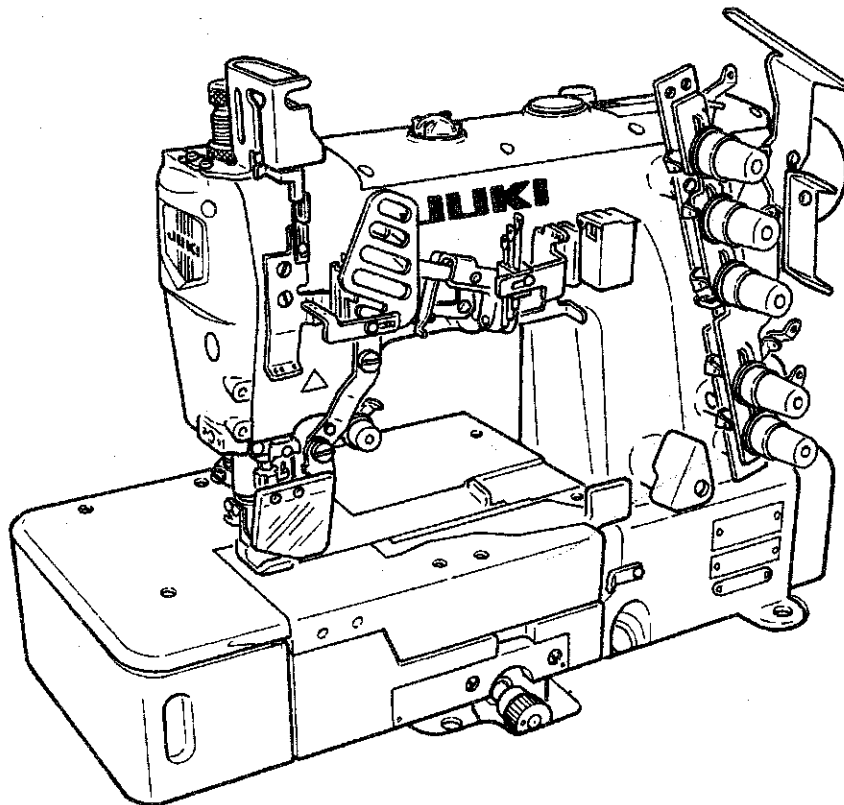

13371604
No.E361-00

PREFACE

This Engineer's Manual is written for the technical personnel who are responsible for the service and maintenance of the machine.

The Instruction Manual for these machines intended for the maintenance personnel and operators at an apparel factory contains operating instructions in detail. And this manual describes "Standard Adjustment", "Adjustment Procedures", "Results of Improper Adjustment", and other important information which are not covered by the Instruction Manual.

It is advisable to use the relevant Instruction Manual and Parts List together with this Engineer's Manual when carrying out the maintenance of these machines.

In addition, for the motor for the sewing machine with thread trimmer, refer to the separate Instruction Manual or Engineer's Manual for the motor. And for the control panel, refer to the Instruction Manual for the control panel.

This manual gives the "Standard Adjustment" on the former page under which the most basic adjustment value is described, and on the latter page "Results of Improper Adjustment" under which stitching errors and troubles arising from mechanical failures are described together with the "Adjustment Procedures".

CONTENTS

1. SPECIFICATIONS	1
2. CONFIGURATION OF THE MACHINE COMPONENTS	2
3. MODEL NUMBERING SYSTEM	3
4. MOTOR PULLEY AND BELT MF-7700 Series	4
5. STANDARD ADJUSTMENT	5
(1) Threading the machine head	5
(2) Adjusting the rocking thread take-up	7
(3) Adjusting the position of the needle thread guide rod	9
(4) Adjusting the position of the thread receiver	11
(5) Adjusting the position of the spreader thread guide and spreader thread take-up	13
(6) Adjusting the spreader	15
(7) Adjusting the timing relation between the looper and needle bar	19
(8) Returning amount of the looper	21
(9) Height of the needle	23
(10) Locus and longitudinal motion of the looper	25
(11) Adjusting the needle guard	27
(12) Instilling cover of the looper and needle guard after adjusting	31
(13) Adjusting the feed dog	33
(14) Adjusting the feed relation	39
(15) Adjusting the presser foot	41
(16) Adjusting the micro-lifter	43
(17) Adjusting the looper thread cam	45
(18) How to change needle bar stroke	47
(19) How to change the spreader	51
(20) With regard to lubrication	53
(21) Adjusting and setting SC-380	55
6. TROUBLES AND CORRECTIVE MEASURES	57
7. DRAWING OF TABLE (SEMI-SUBMERGED TYPE)	71

1. SPECIFICATIONS

No.	Item	Specifications
1	Model name	High-speed, flat-bed coverstitch machine
2	Model	MF-7700 series
3	Stitch type	ISO standard 406, 407, 602, and 605
4	Example of application	Hemming and covering for knits and general knitted fabrics
5	Max. sewing speed	Max. 6,500 rpm (at the time of intermittent operation)
6	Needle gauge	3-needle ... 4.8 mm, 5.6 mm, and 6.4 mm 2-needle ... 4.0 mm (3.2 mm can be accepted as special order)
7	Differential feed ratio	1 : 0.7 to 1 : 2 (stitch length : less than 2.5 mm) Micro-differential feed adjustment mechanism is provided. (Micro-adjustment)
8	Stitch length	1.2 mm to 3.6 mm (can be adjusted up to 4.4 mm)
9	Needle	UY128GAS ORGAN #9S to #14S (standard #10S) (SCHMETZ Nm65 to Nm90, standard Nm70)
10	Needle bar stroke	31 mm (standard), possible up to 33 mm by adjustment)
11	Dimensions	(Height) 451 x (Width) 515 x (Length) 265
12	Weight	46kg
13	Lift of presser foot	8 mm (needle gauge : 5.6 mm without top covering), and 5 mm (with top covering) Micro-lifter mechanism is provided.
14	Feed adjustment method	Main feed ... dial type stitch pitch adjustment method Differential feed ... lever adjustment method (micro-adjustment mechanism is provided.)
15	Looper mechanism	Spherical rod drive method
16	Lubricating system	Forced lubrication method by gear pump
17	Lubricating oil	JUKI MACHINE OIL 18 (Equivalent to ISO VG18)
18	Oil reservoir capacity	Oil gauge lower line : 600 cc to upper line : 900 cc
19	Installation	Semi-submerged type
20	Needle tip, needle thread and silicon oil lubricating unit.	Provided as standard
21	Noise	Workplace-related noise at sewing speed n= 5000 min ⁻¹ : L _{PA} ≤ 78 dB (A) Noise measurement according to DIN 45635-48-A-1.

2. CONFIGURATION OF THE MACHINE COMPONENTS

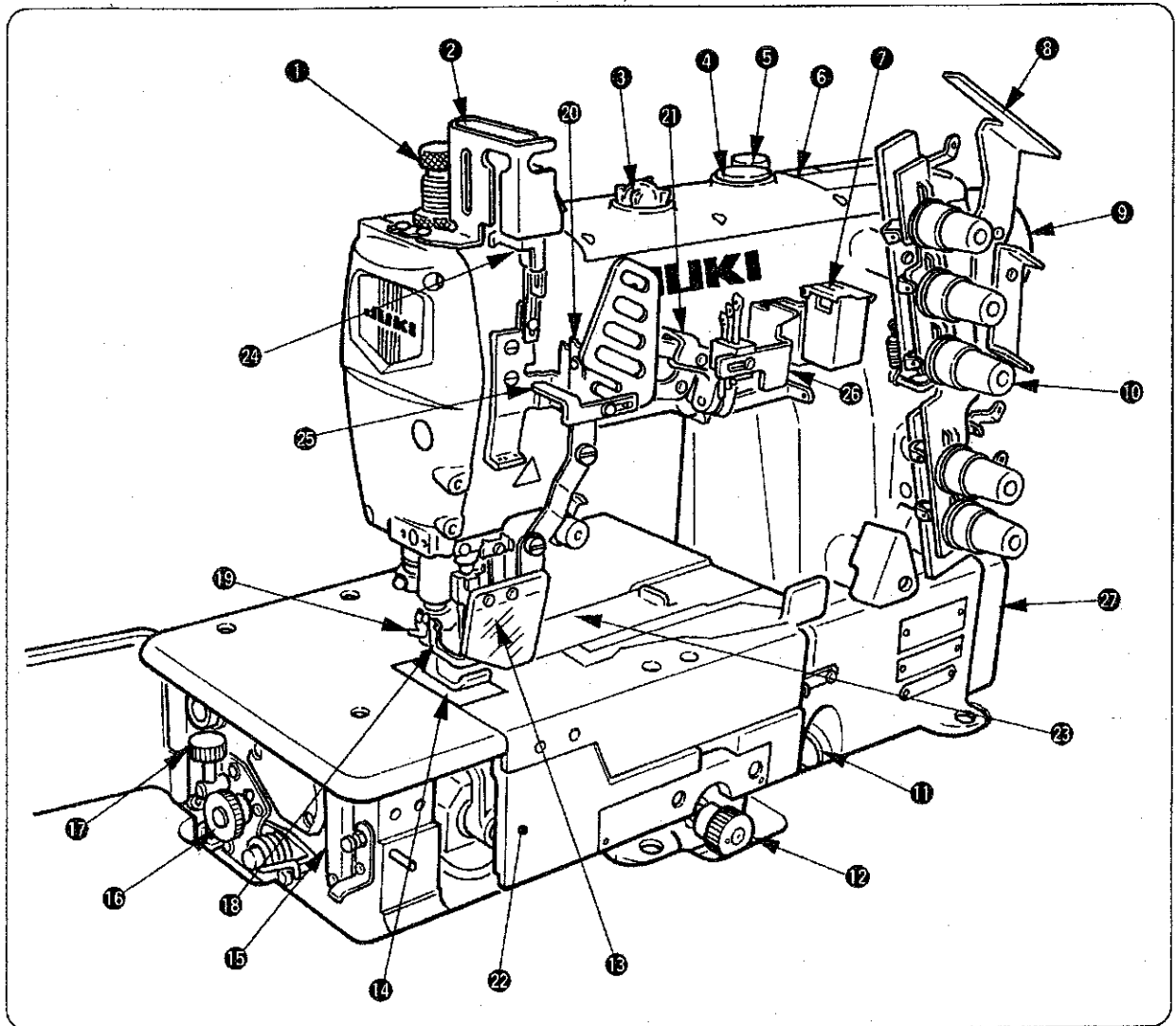

- | | | |
|--|---|---|
| ① Presser spring regulator | ⑩ Thread tension nut | ⑲ Thread trimming knife |
| ② Needle bar thread take-up cover | ⑪ Oil gauge | ⑳ Rocking thread take-up receiver |
| ③ Oil circulation identification window | ⑫ Feed regulating knob | ㉑ Rocking thread take-up |
| ④ Oil hole cap | ⑬ Eye guard cover | ㉒ Front cover |
| ⑤ Micro-lifter | ⑭ Throat plate | ㉓ Slide cover |
| ⑥ "Oil" indication | ⑮ Needle tip silicon oil lubricating unit | ㉔ Needle bar thread take-up thread receiver |
| ⑦ Needle thread silicon oil lubricating unit | ⑯ Differential lock nut | ㉕ Rocking thread take-up thread guide |
| ⑧ Thread guide No. 1 | ⑰ Micro-adjustment knob | ㉖ Silicon container thread guide |
| ⑨ Upper pulley | ⑱ Finger guard | ㉗ Belt cover |

3. MODEL NUMBERING SYSTEM

High-Speed, Flat-bed Coverstitch Machine

Applicable model : MF-7700 Series

1 2 3 4 5 6 7 8 9 10 11 12 13 14 15 16 17 18 19 20 21 22 23 24 25
MF 7 7 △ △ □ △ △ **B** △ △ / □ □ △ △ / □ □ △ △ - □ □

3-6	Model code
7722	2-needle top & bottom covering stitch
7723	3-needle top & bottom covering stitch

Application code		
7-9	Application	Description
U10	For universal	Lapseam, Covering, Hemming
C10	For collarete	Collarete

10	Tongue shape of throat plate
B	B-type (Standard)

11-12	Needle gauge	Availability			
		For 2-needle	For 3-needle	U10	C10
40	4.0mm	Avail	-	-	Avail
48	4.8mm	Avail	Avail	Avail	-
56	5.6mm	Avail	Avail	Avail	Avail
64	6.4mm	Avail	Avail	Avail	Avail

14-22	Device and attachment
(blank)	Not provided

* When device or attachment is one, delete slash (/) of 13th digit.

24	Destination
A	Standard

25	Accessory
A	Standard

4. MOTOR PULLEY AND BELT MF-7700 Series

Sewing speed (rpm)	50Hz		60Hz	
	Pulley size (mm)	Belt size (inch)	Pulley size (mm)	Belt size (inch)
4,500	ø 100	M-35	ø 85	M-35
4,800	ø 105	M-36	ø 90	M-35
5,000	ø 115	M-36	ø 95	M-35
5,500	ø 125	M-37	ø 105	M-36
5,800	ø 130	M-37	ø 110	M-36
6,000	ø 135	M-37	ø 115	M-37
6,200	ø 140	M-38	ø 120	M-38
6,500	ø 150	M-39	ø 125	M-38

1. The table shows the numbers when a 3-phase 2-pole 400 W clutch motor (1 / 2 HP) is used.
 2. The commercially-available motor pulley near to the counted value is designated since the outside diameter of the commercially-available motor pulley counts by 5 mm.
 3. When you use a new sewing machine, use the machine at a speed of 5,000 rpm or less for the first 200 hours (approximately one month). A good result can be obtained in terms of the durability.
- (Caution)**
1. Use a motor pulley which is adaptable to this sewing machine.
 2. The sewing speed exceeds the max. sewing speed of this sewing machine and machine trouble will be caused unless a motor pulley which is adaptable to this sewing machine is used.

5. STANDARD ADJUSTMENT

(1) Threading the machine head

Standard Adjustment

1. Threading for standard seame

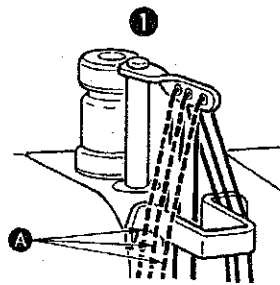
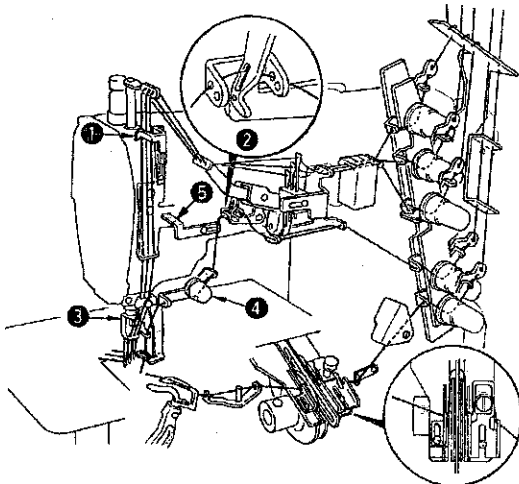

Broken lines **A** when stretcher thread is used

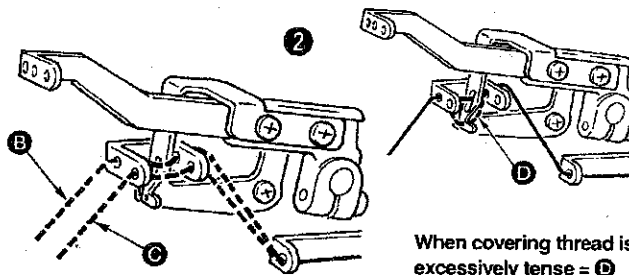

When covering thread is excessively tense = **B**

When covering thread is excessively loosened = **B**
When covering thread is excessively loosened even after passing **B** = **C**

When using more stretchable thread

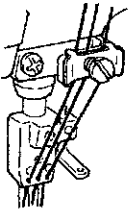

When using less stretchable thread

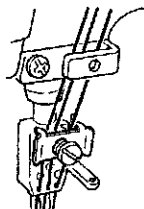

(Caution) In case of threading for standard seams, rocking thread take-up thread guide **5** is not used.

2. Threading for soft seams

- (1) Do not pass needle thread through needle bar thread take-up **3**.
- (2) When soft seams are required, change the threading of needle thread and slide the position of looper thread cam eyelet.
- (3) Do not pass needle thread through needle bar thread take-up **6**. Pass the thread from rocking thread take-up **9** to rocking thread take-up thread guide **5**.
- (4) Other points are same as those of "1. Threading for standard seame".

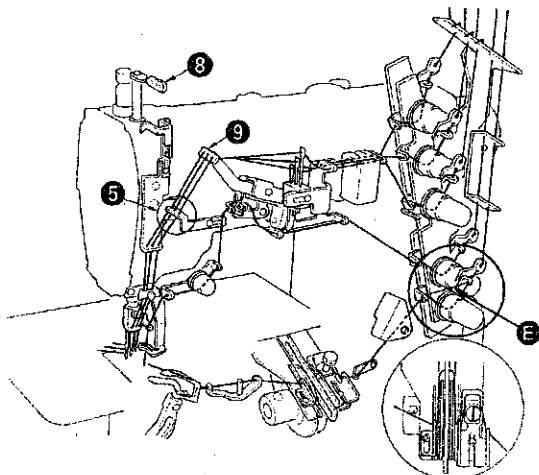

In case of soft seams

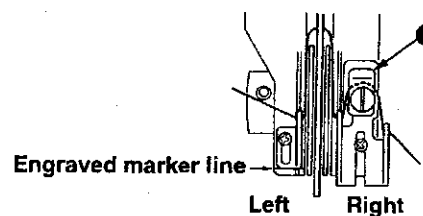

Engraved marker line

Left Right

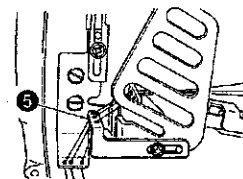

(Caution) In case of the soft seams, rocking thread take-up thread guide **5** is used.

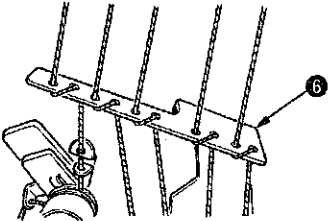
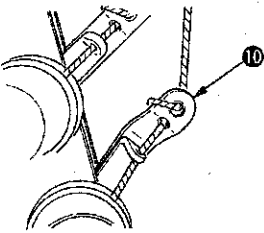
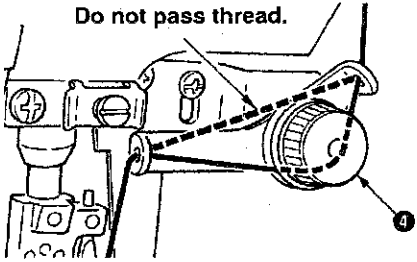
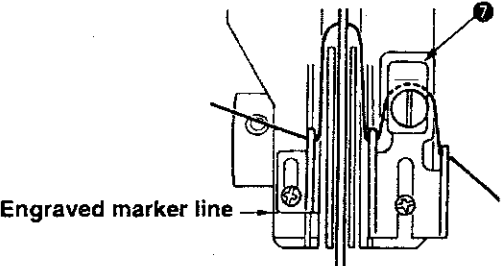
Standard Adjustment	Results of Improper Adjustment
<p>1. When motion of thread is very rough, and stable seams can not be obtained, there are cases where the condition can be improved by the following threading.</p> <p>(1) Wind thread around 1st thread guide ⑥.</p>  <p>(2) Wind thread around the thread tension thread guide ⑩.</p>  <p>2. When using more stretchable thread (wooly thread or the like), the threading as given below does not make thread stretch and neat seams can be obtained.</p> <p>(1) Do not pass thread through spreader auxiliary thread tension ④.</p>  <p>(2) Do not pass thread through the looper thread tension disk. Refer to section ⑤.</p> <p>(Caution) Even when using wooly thread or the like, seams are more stabilized by passing thread through looper thread auxiliary thread tension ⑦.</p> 	<ul style="list-style-type: none"> ○ When threading is not properly performed, not only sewing trouble occurs, but also needle breakage is caused. So, be careful.

(2) Adjusting the rocking thread take-up

Standard Adjustment

1. Length of the rocking thread take-up

- (1) It is the standard that the length of rocking thread take-up ② from the center of the shaft of rocking thread take-up support arm ④ to the thread hole face of rocking thread take-up ② is 95 mm.

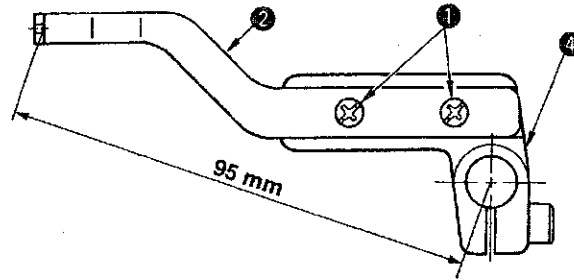

2. Position of the rocking thread take-up

- (1) Install so that rocking thread take-up ② is flush with rocking thread take-up ② when the needle bar is in its lowest position.

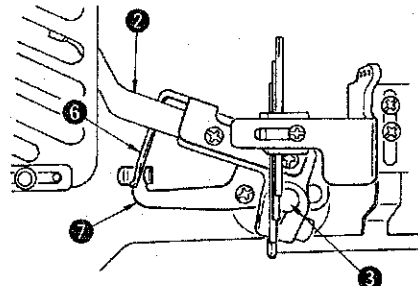
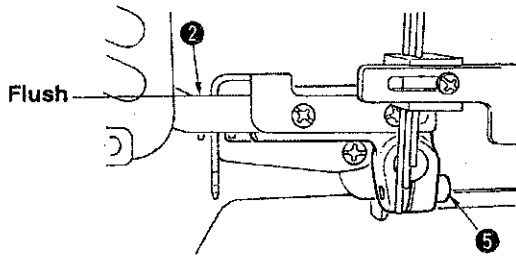

3. Timing of the rocking thread take-up

- (1) It is the standard timing that rocking thread take-up ② is in its lowest position as well when the needle bar is in its lowest position.

Timing of rocking thread take-up ② is performed by adjusting the position of rocking thread take-up ball arm ⑧.

4. Relation between the timing of rocking thread take-up and the needle thread loop

- (1) When using the excessively stretchable thread or the hard-to-stretch thread, the size of needle thread loop can be changed by changing the timing of rocking thread take-up ②.

- (2) Relation between the timing of the rocking thread take-up and the size of needle thread loop is as shown in the table on the next page.

(The relation becomes reverse when using the needle bar thread take-up = standard seams and when it is not used = soft seams. So, be careful.)

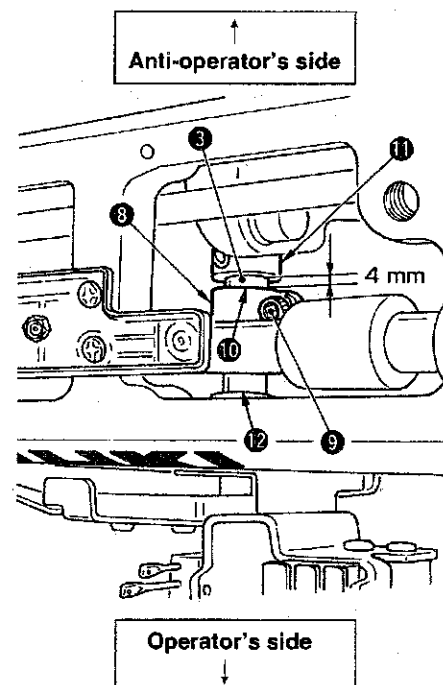

Standard Adjustment	Results of Improper Adjustment									
<p>1. Length of the rocking thread take-up</p> <p>(1) Loosen screws ❶ and move rocking thread take-up ❷ to the right or left to adjust the length.</p> <p>2. Position of the rocking thread take-up</p> <p>(1) Loosen screw ❸ and move rocking thread take-up ❷ up or down to adjust the position.</p> <p>(Caution) When adjusting the position of rocking thread take-up ❷, adjust the rocking thread take-up to the same plane of the edge of rocking thread take-up shaft ❹ and fix it so that spreader thread take-up ❺ and spreader thread guide ❻ do not come in contact with each other.</p> <p>3. To adjust the timing of the rocking thread take-up ❷, remove the top cover, loosen setscrew ❽ in the rocking thread take-up ball arm and move the position of rocking thread take-up ball arm ❸ to and fro.</p> <p>(1) Standard adjustment figure is the position where the rear end (anti-operator's side) of rocking thread take-up ball arm ❸ aligns with engraved marker line ❿ on rocking thread take-up shaft ❹. (As the standard at this time, note that the clearance provided between the rear end of rocking thread take-up ball arm ❸ and thrust collar ❶ is 4 mm.)</p> <p>(Caution) 1. When loosening screw ❽ in rocking thread take-up ball arm ❸, there is a case where rocking thread take-up ❷ rotates by its weight. After the adjustment, be sure to check the rocking position (flush at the lowest position) of rocking thread take-up ❷.</p> <p>2. When moving rocking thread take-up ball arm ❸ to the operator's side, adjust rocking thread take-up ball arm ❸ within the range where it does not come in contact with rocking thread take-up bushing ⓫ (operator's side).</p>	<ul style="list-style-type: none"> ○ When length of rocking thread take-up ❷ is lengthened, needle thread is tightened. <p>(Caution) When lengthening rocking thread take-up ❷, check whether it comes in contact with the thread take-up cover.</p> <ul style="list-style-type: none"> ○ When length of rocking thread take-up ❷ is shortened, needle thread is loosened. ○ When installing position of rocking thread take-up ❷ is raised, needle thread is loosened when the needle bar thread take-up is used, and needle thread is tightened when the needle bar thread take-up is not used. 									
<p>4. Relation between timing of rocking thread take-up and needle thread loop</p> <table border="1" data-bbox="348 1493 1417 1633"> <thead> <tr> <th></th> <th>Delay timing (Move to operator's side.)</th> <th>Advance timing (Move to anti-operator's side.)</th> </tr> </thead> <tbody> <tr> <td>When needle bar thread take-up is used</td> <td>Loop becomes small.</td> <td>Loop becomes large.</td> </tr> <tr> <td>When needle bar thread take-up is not used</td> <td>Loop becomes large.</td> <td>Loop becomes small.</td> </tr> </tbody> </table> <p>Adjusting procedure is the same as step 3. Loosen setscrew ❽ in rocking thread take-up ball arm ❸ and adjust the position of rocking thread take-up ball arm ❸.</p> <p>(Caution) Adjust the timing of rocking thread take-up ❷ each time in accordance with thread used or conditions.</p>		Delay timing (Move to operator's side.)	Advance timing (Move to anti-operator's side.)	When needle bar thread take-up is used	Loop becomes small.	Loop becomes large.	When needle bar thread take-up is not used	Loop becomes large.	Loop becomes small.	
	Delay timing (Move to operator's side.)	Advance timing (Move to anti-operator's side.)								
When needle bar thread take-up is used	Loop becomes small.	Loop becomes large.								
When needle bar thread take-up is not used	Loop becomes large.	Loop becomes small.								

(3) Adjusting the position of the needle thread guide rod

Standard Adjustment

1. Position of the needle thread guide rod

(1) It is the standard that the height of needle thread guide rods ① is the position where the dimensions from the top surface of needle thread guide base ② to the bottom end of the hole are as follows.

Left needle **A** : 7 mm

Middle needle **B** : 15 mm

Right needle **C** : 23 mm

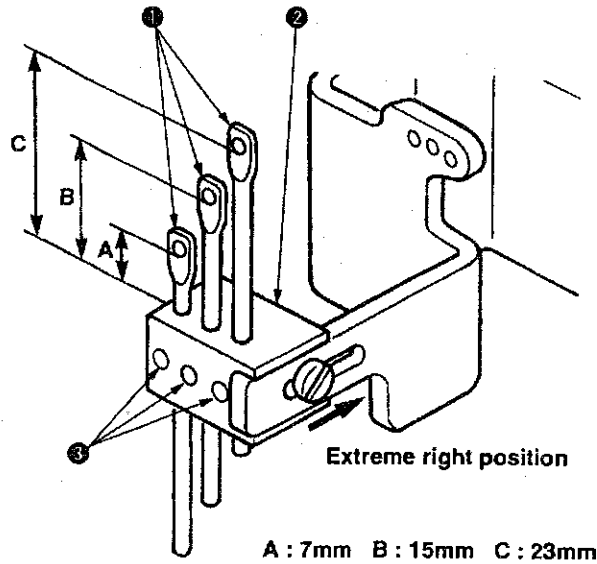

2. Adjusting the position of needle thread guide base and silicon container thread guide

(1) It is the standard that the height of silicon container thread guide ④ (refer to 2. CONFIGURATION OF THE MACHINE COMPONENTS) is the position where the height from the center of setscrew ⑤ to the bottom end of thread hole is 9 mm.

(2) Move the lateral position of needle thread guide base ② fully to the right of slot (43 mm).

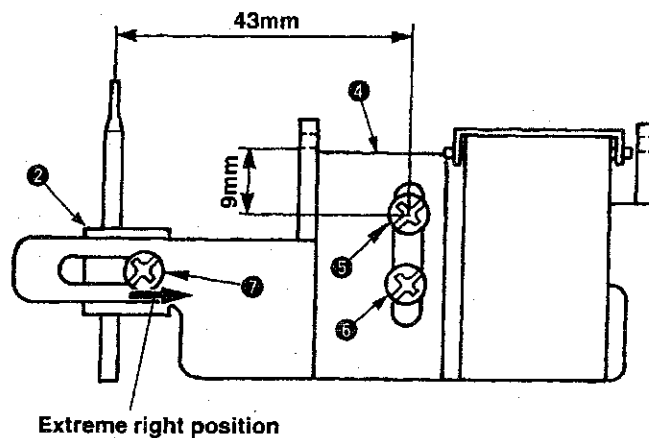

Standard Adjustment	Results of Improper Adjustment
<p>1. Loosen setscrews ③, adjust the height of respective needle thread guide rods ①, and fix the rods with setscrews ③.</p> <p>(Caution) 1. Move the lateral position of needle thread guide base ② fully to the right of slot.</p> <p>2. When adjusting the height of needle thread guide rods ①, install the rods so that the thread holes are parallel to the thread holes of silicon container thread guide ④ so that excessive resistance is not applied to threads.</p> <p>2. Adjusting the position of needle thread guide base and silicon container thread guide</p> <p>(1) Loosen setscrews ⑤ and ⑥ and move silicon container thread guide ④ up or down to adjust the height.</p> <p>(2) Loosen setscrew ⑦ and adjust the lateral position of needle thread guide base ②.</p>	<ul style="list-style-type: none"> ○ When needle thread guide rod ① is raised, needle thread is loosened. ○ When needle thread guide rod ① is lowered, needle thread is tightened. ○ When silicon container thread guide ④ is raised, needle thread is loosened. ○ When silicon container thread guide ④ is lowered, needle thread is tightened. ○ When needle thread guide base ② is moved to the left, needle thread is loosened.

(4) Adjusting the position of the thread receiver

Standard Adjustment

1. Position of the needle bar thread take-up thread receiver (in case of standard seams)

- (1) It is the standard that the height of needle bar thread take-up thread receiver ① is in the position where the bottom end of thread hole to the center of needle bar thread take-up ② aligns with the top surface of needle bar thread take-up thread receiver ① when the needle bar is in its lowest position.

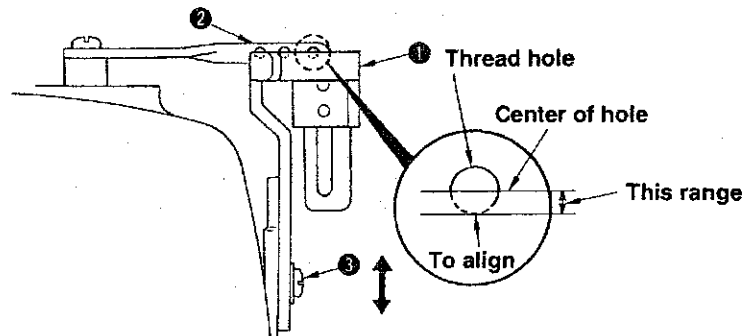

1. Position of the rocking thread take-up thread receiver (in case of soft seams)

(In case thread is not passed through needle bar thread take-up ②)

- (1) It is the standard that the height of rocking thread take-up receiver ⑦ is in the position where the top surface of rocking thread take-up receiver ⑦ is in the range of the center to the top end of thread hole ⑨ of rocking thread take-up ⑧ when rocking thread take-up ⑧ is in its lowest position.

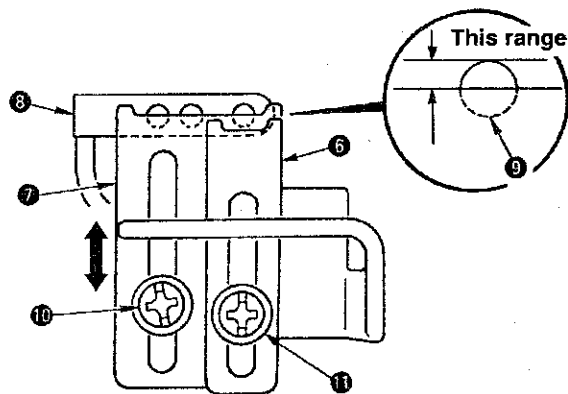

(5) Adjusting the position of the spreader thread guide and spreader thread take-up

Standard Adjustment

1. Relation of the position between spreader thread take-up ① and spreader thread guide ② is the standard when the top end of thread hole ⑤ of spreader thread guide ② aligns with the bottom end of slot ⑤ of spreader thread take-up ① when spreader thread take-up ① is in its highest position.
Adjust the relation of the position so that thread is moderately stretched when spreader thread take-up ① is in its highest position in accordance with thread used or conditions.

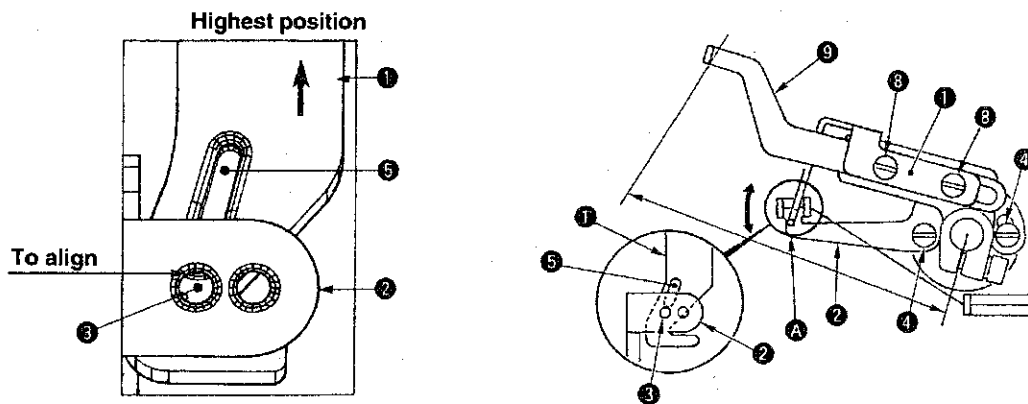

2. Standard position of the spreader auxiliary thread tension
Standard adjustment figure of the spreader auxiliary thread tension is the standard when the top end of thread tension rod ⑥ is flush with knob ⑦.

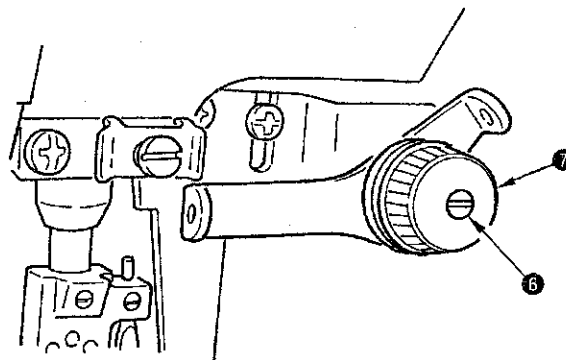

Standard Adjustment	Results of Improper Adjustment
<p>1. Loosen setscrews ④ in spreader thread guide ② and adjust the position of spreader thread guide ②. (Spreader thread take-up ① is fixed to rocking thread take-up ③ and can not be adjusted in the height direction.)</p> <p>2. After the adjustment, turn the sewing machine by hand and check whether spreader thread take-up ① comes in contact with spreader thread guide ②, or section A of clearance is too small.</p> <p>3. Adjusting procedure of the clearance (1) Loosen setscrews ④ in spreader thread guide ② and adjust in the lateral direction, or loosen setscrews ⑧ in the rocking thread take-up and move spreader thread take-up ① to the right or left to adjust the clearance.</p> <p>(Caution) When loosening setscrews ⑧ in the rocking thread take-up and adjusting the position of spreader thread take-up ①, adjust so that 95, length of rocking thread take-up ③ (95mm) does not change.</p>	<ul style="list-style-type: none"> ○ When the relation of position between spreader thread take-up ① and the spreader thread guide is not proper, sewing troubles such as stitch skipping and the like will be caused. ○ If thread is less stretched and slackness of thread occurs at the thread take-up section when spreader thread take-up ① is in its highest position, the spreader fails to pick up thread and stitch skipping occurs. ○ If stretch or feeding of thread is excessive when spreader thread take-up ① is in its highest position, not only thread on the seam side is drawn and needle thread can not be tightened, but also needle bend or needle breakage will be caused. ○ If stretch or feeding of thread is excessive when spreader thread take-up ① is in its lowest position, thread slacks when the spreader moves from left to right and stitch skipping occurs.

(6) Adjusting the spreader

Standard Adjustment

1. Height of the spreader

It is the standard that the height from the top surface of throat plate ② to the bottom surface of spreader ① is 8.3 to 8.7 mm.

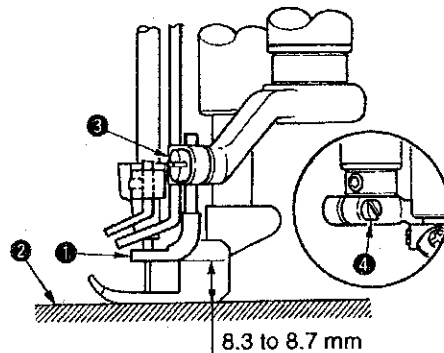

2. Longitudinal position of the spreader

It is the standard that when spreader ① returns from the extreme left position to the right and top end A of thread hooking section reaches to the front of left needle, the clearance between the spreader and the left needle is 0.1 to 0.3 mm.

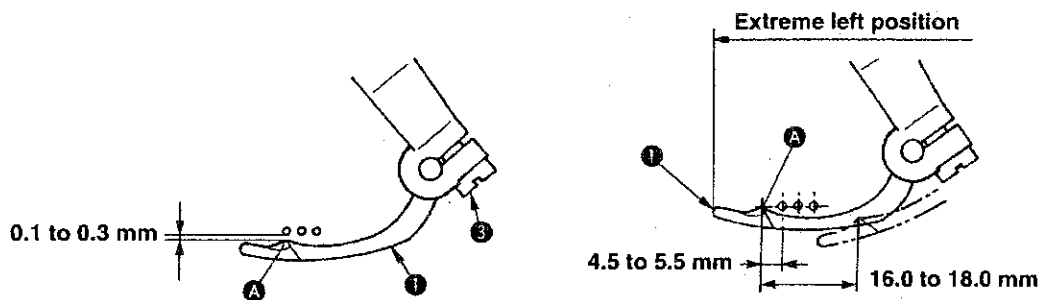

3. Protruding amount

It is the standard that the dimension from the center of left needle to top end A of thread hooking section, when spreader ① is in the extreme left position, is 4.5 to 5.5 mm.

4. Spreader stroke

It is the standard that the spreader stroke is 16 to 18 mm at the stroke of thread hooking section.

5. Timing of the spreader

Standard position is the position where the spreader ① is in the extreme left position when the needle bar comes down from the upper dead point by 1.1 ± 0.1 mm.

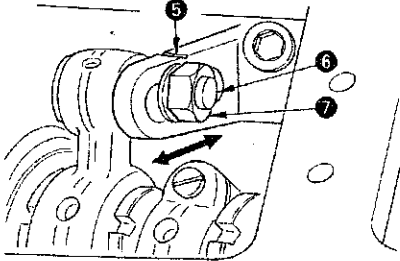
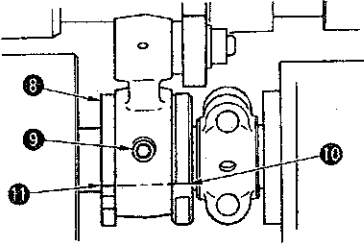
Standard Adjustment	Results of Improper Adjustment
<p>1. Adjusting the height of the spreader</p> <p>2. Adjusting the longitudinal position of the spreader Loosen setscrew ③ and adjust the height and longitudinal position of the spreader ①.</p> <p>3. Protruding amount of the spreader Loosen setscrew ④ in the spreader folder and adjust the protruding amount. Adjust aiming the adjustment figure of 5 mm.</p> <p>4. Adjusting the spreader stroke Standard position is the position where the engraved marker line of spreader drive lever ⑤ aligns with the center of the shaft of connecting pin ⑥. When desired to increase the stroke, loosen lock nut ⑦ and move in the right direction. When desired to decrease the stroke, loosen lock nut ⑦ and move in the left direction. Adjust aiming the adjustment figure of 17 mm.</p>	<ul style="list-style-type: none"> ○ Height of the spreader is improper, stitch skipping of spreader occurs. ○ Adjust the height in accordance with the needle gauge. ○ Even when the protruding amount is excessive or insufficient, stitch skipping of spreader will be caused. ○ When the protruding amount is insufficient, it will be the cause for left needle not to scoop covering thread at overlapped section. ○ When the stroke is increased, disorder of covering thread stitching will be caused. ○ When the stroke is decreased, stitch skipping of spreader will be caused. ○ When the timing is excessively advanced, needle does not take covering thread when it comes down and stitch skipping will be caused. ○ When the timing is excessively retarded, resistance increases when covering thread slips out from the spreader and a load is applied to the right needle. As a result, needle breakage or stitch skipping will be caused.
 <p>5. Adjusting the timing between the needle bar and the spreader When changing the timing, loosen two setscrews ⑨ in spreader eccentric cam ⑧ to adjust. Standard position is the position where notch ⑩ in the main shaft aligns with notch ⑪ in spreader eccentric cam. When changing, turn the upper pulley and change with spreader eccentric cam ⑧ fixed.</p>	<p>(Caution) When changing, temporarily tighten No. 2 screw in the rotation direction of setscrews ⑨ and turn the upper pulley to change.</p>
	

(6) Adjusting the spreader

Standard Adjustment

6. Adjustment figures of the spreader thread guide

- (1) It is the standard that the clearance provided between spreader ① and spreader thread guide ⑫ is 0.4 to 1.0 mm.
- (2) It is the standard that the clearance provided between spreader thread guide ⑫ and needle clamp thread guide ⑬ is 0.8 to 1.2 mm.
- (3) Lateral position of the spreader thread guide
Top end of thread hooking section ④ of the spreader aligns with center ⑤ of slot ③ in spreader thread guide ⑫ when spreader ① is in the extreme right position.

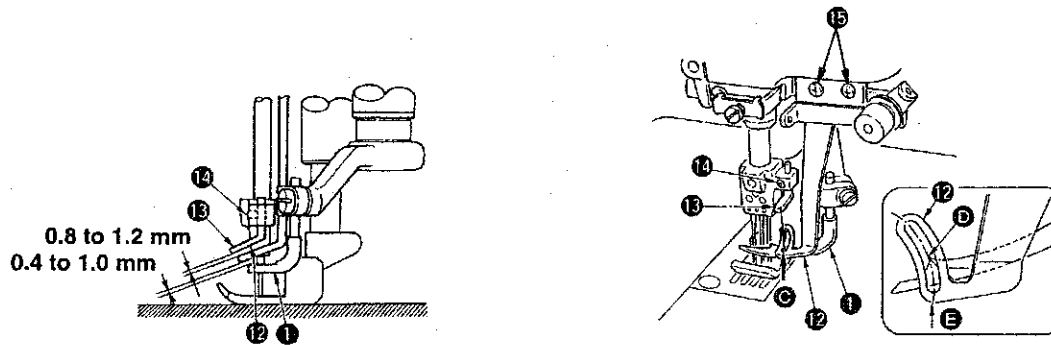

(7) Adjusting the timing relation between the looper and needle bar

Standard Adjustment

1. Timing relation between the looper and the needle bar (synchronization)

It is the standard that dimension **A** from the top end of needle eyelet to the blade point of looper passes the rear of the needle and comes to the position of the right end of left needle is the same as dimension **B** from the top end of needle eyelet to the blade point of looper when needle bar comes down from the upper dead point, the blade point of looper passes the front of needle bar and comes to the position of the right end of left needle. (**A=B**)

Going of looper

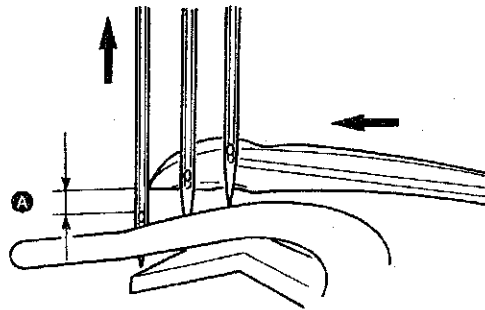

Returning of looper

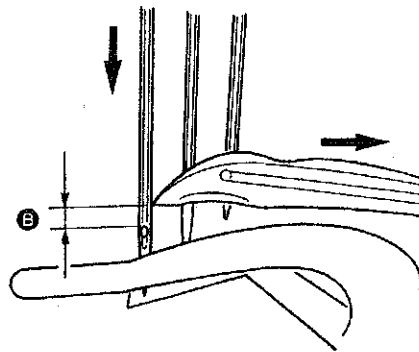

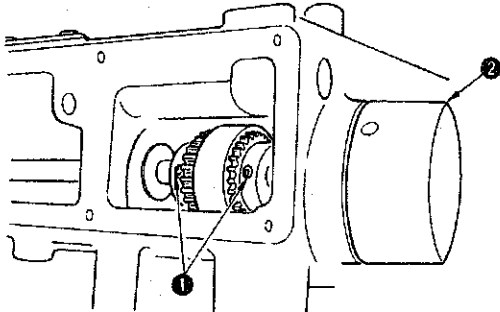
Standard Adjustment	Results of Improper Adjustment
<p>1. To adjust the timing relation between the needle and the looper, remove the top cover, loosen four setscrews ❶ in the sprocket and turn upper pulley ❷ in the state that the sprocket is held.</p>  <p>2. Adjusting procedure</p> <p>(1) When adjusting the timing to "0" (zero)</p> <p>1) In case dimension A when the looper advances is smaller than dimension B when the looper retreats, the looper timing is retarded (needle timing is advanced). In this case, loosen setscrews ❶ in the sprocket and finely turn upper pulley ❷ in the reverse direction.</p> <p>2) In case dimension A when the looper advances is larger than dimension B when the looper retreats, the looper timing is advanced (needle timing is retarded). In this case, loosen setscrews ❶ in the sprocket and finely turn upper pulley ❷ in the normal direction.</p> <p>(Caution) Be careful not to excessively turn upper pulley ❷.</p> <p>3. After the adjustment, fix four setscrews ❶ in the sprocket.</p>	<ul style="list-style-type: none"> ○ When the difference in timing (going and returning) of looper is excessively large, stitch skipping or entangling of needle thread will be caused.

(8) Returning amount of the looper

Standard Adjustment

1. It is the standard that returning amount of looper ❶ from top end of looper ❶ to the center of needle bar is 6.5 mm regardless of the needle gauge when looper ❶ is in the extreme right position.

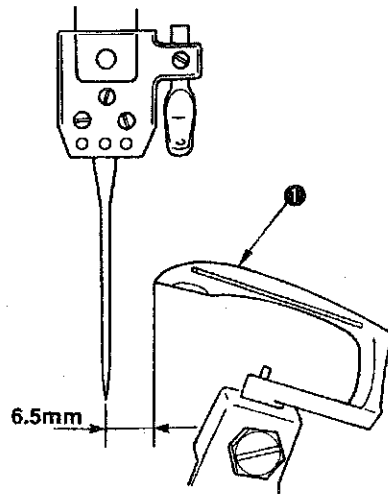

2. Returning amount of looper for each gauge (dimension ❸)

Unit : mm

2-needle		3-needle	
Needle gauge	Returning amount ❸	Needle gauge	Returning amount ❸
3.2	4.9	-	-
4	4.5	-	-
4.8	4.1	4.8	4.1
5.6	3.7	5.6	3.7
6.4	3.3	6.4	3.3

(Dimension ❸ is the dimension from the center of right needle to the top end of looper ❶.)

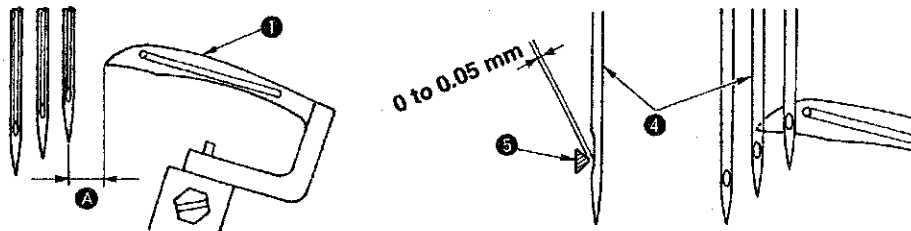

Standard Adjustment	Results of Improper Adjustment
<p>1. Loosen setscrew ② in the looper holder and move looper holder ③ to the right and left to adjust.</p> <p>2. After the adjustment, tighten setscrew ② in the looper holder.</p> <div data-bbox="459 478 822 772" data-label="Image"> </div> <p>(Caution) When adjusting looper holder ③, adjust the lateral position while being careful that the holder does not move to and fro.</p> <p>3. Longitudinal position Adjust so that the clearance provided between blade point ⑤ of looper and middle needle ④ is 0 to 0.05 mm when the top end of looper comes to the center of middle needle from the extreme right position. After the adjustment, fix the looper holder with setscrew ② in the looper holder.</p> <p>* Blade point ⑤ of the looper comes in contact with the right needle when rear needle guard ⑥ fails to work. So, be careful.</p>	<ul style="list-style-type: none"> ○ When the returning amount is large, loop of needle thread becomes large and it is apt to fall. As a result, stitch skipping or thread breakage will be caused, and stitch skipping on the back is apt to occur. In addition, thread tangling will be caused. ○ When the returning amount is small, loop of needle thread is small and stitch skipping or thread breakage will be caused. In addition, thread tangling will be caused.

(9) Height of the needle

Standard Adjustment

1. It is the standard that the top end of needle eyelet of left needle aligns with the bottom end of looper when the top end of looper passes the rear of the needle from the extreme right position and protrudes from the left end of left needle by approximately 1 mm (1.1 mm), dimension B.

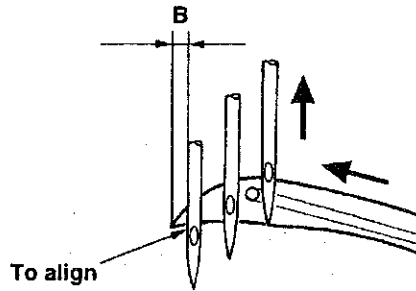

Reference : Dimension C, height of left needle from top surface **A** of throat plate

Unit : mm

2-needle		3-needle	
Needle gauge	Height of left needle C	Needle gauge	Height of left needle C
3.2	9.7	—	—
4.0	9.3	—	—
4.8	8.8	4.8	8.8
5.6	8.5	5.6	8.5
6.4	8.0	6.4	8.0

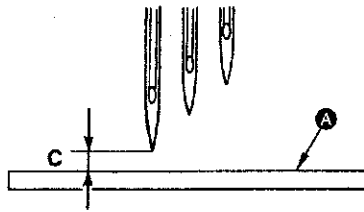

2. Scooping height of looper, dimension from the top end of needle eyelet to the top end of looper is 1.2 to 1.4 mm.

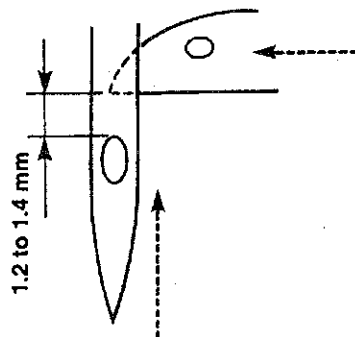

Standard Adjustment

1. Remove rubber cap ❶ in the face plate, loosen setscrew ❸ in the needle bar bracket and adjust the height of the needle bar.
2. After adjusting the height, equally adjust the clearance A between needle ❶ and needle hole ❷ in the throat plate and fix the needle bar with setscrew ❸ in the needle bar bracket.

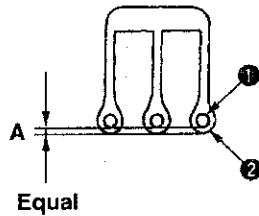
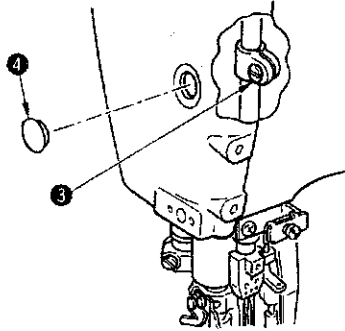

Results of Improper Adjustment

- When the height of the needle is excessively different, stitch skipping, needle breakage, thread breakage, etc. will be caused.

(10) Locus and longitudinal motion of the looper

Standard Adjustment

1. Standard longitudinal motion of the looper

- (1) It is the standard that the top end of left needle touches the position of $1/4$ to $1/3$ from the bottom face of the back of the looper when the looper returns from the extreme left position.
- (2) The position where the engraved marker line on looper drive arm ② aligns with the center of the shaft of pin is the standard.

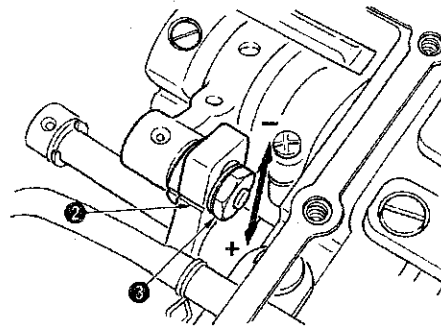
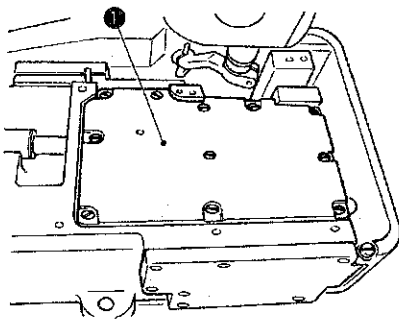
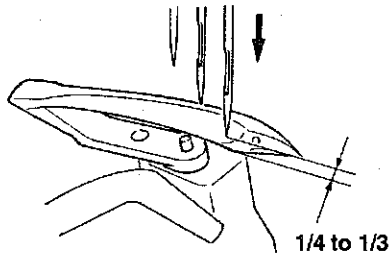

2. Locus of the looper

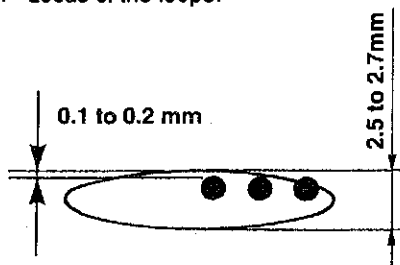

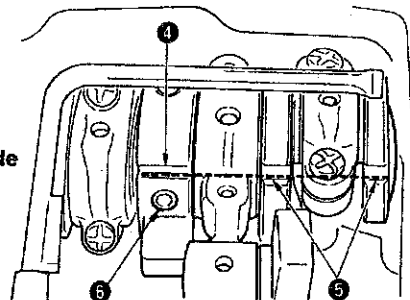

Lower pulley side



It is the standard locus of the looper that the clearance between the top end of looper and middle needle is within 0.05mm (when the rear needle guard fails to work) and the looper passes the left needle with a clearance of 0.1 to 0.2 mm.

The standard position of the cam is the position where the notch of looper longitudinal motion eccentric cam ④ aligns with notches ⑤ of looper driving shaft.

Standard Adjustment	Results of Improper Adjustment
<p>1. Changing the longitudinal motion of the looper</p> <p>(1) Remove 11 setscrews in bed top cover ❶ and remove the cover.</p> <p>(2) When increasing the longitudinal motion of the looper, loosen nut ❷ and lower the arm downward (+) from the engraved marker line.</p> <p>(3) When decreasing the longitudinal motion of the looper, loosen nut ❸ raise the arm upward (-) from the engraved marker line.</p> <p>Perform the adjustment in accordance with the needle used.</p> <p>(Caution) After adjusting the longitudinal motion of the looper, move the looper holder and re-adjust the longitudinal position of the needle and the looper. (Refer to "(8) Returning amount of the looper.)</p> <p>2. Changing the locus of the looper</p> <p>(1) Loosen two setscrews ❹ in the cam and change the locus of the looper by turning the upper pulley with the cam fixed.</p> <p>When it is turned in the direction of rotation, the timing is retarded, and when turning in the reverse direction of rotation, the timing is advanced.</p> <p>(Caution)</p> <ol style="list-style-type: none"> 1. It is possible to change the locus of the looper. However, do not excessively change it from the standard position. 2. When changing the locus of the looper, be sure to check whether the top end of left needle touches the position of 1/4 to 1/3 from the bottom face of the back of the looper. 	<ul style="list-style-type: none"> ○ When the longitudinal motion of the looper is small, the rate that needle touches the back of the looper is increased and blunt needle tip will be caused. ○ When the longitudinal motion of the looper is large, the clearance provided between the needle and the back of the looper is increased and stitch skipping at the time of returning of the looper will be caused. ○ When the timing is advanced, stitch skipping is apt to occur at the time of going of the looper, and especially the clearance provided between the looper and the left needle is widened. Needle strongly touches the back of the looper and blunt needle tip will be caused.  <ul style="list-style-type: none"> ○ When the timing is retarded, stitch skipping is apt to occur at the time of returning of the looper. Chain-off thread does not come out smoothly.  <ul style="list-style-type: none"> ○ When removing the top cover for adjustment or the like, sealant is peeled off. As a result, oil leakage will be caused.

(11) Adjusting the needle guard

Standard Adjustment

1. Standard position of the rear needle guard

(1) Lateral position of rear needle guard ❶

It is the standard that the lateral position of rear needle guard ❶ is the position where the rear needle guard receives the needle in the range of **B**.

(2) Position of the height of the rear needle guard

It is the standard that ridge line **A** of rear needle guard ❶ enters in the needle eyelet of right needle when the needle bar is in its lower dead position.

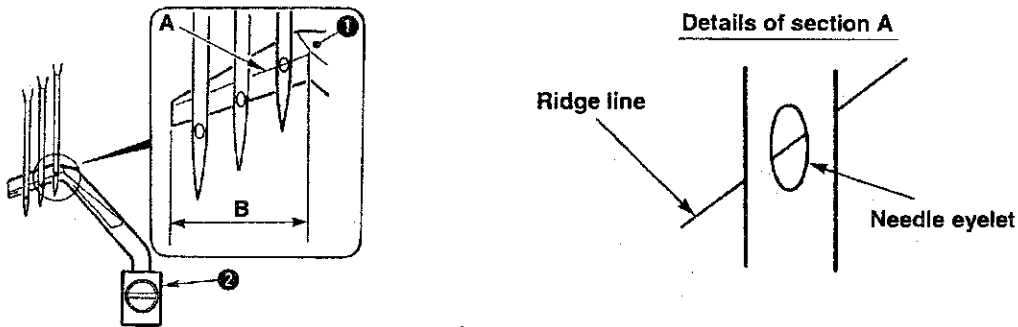

(3) Pressing amount of the rear needle guard

When the top end of looper ❸ comes from the extreme right position to the center of right needle, the clearance provided between the needle and the top end of looper ❸ becomes 0 to 0.05 mm. Make rear needle guard ❶ lightly touch the right needle and the pressing amount of the top end of needle becomes 0.1 to 0.2 mm.

It is the standard for the middle needle that when the top end of looper ❸ comes to the center of middle needle, the clearance provided between the middle needle and the top end of looper becomes 0 to 0.05 mm and the pressing amount of the top end of the needle is such an amount that rear needle guard ❶ lightly touches the middle needle.

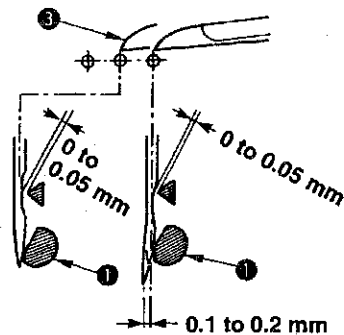

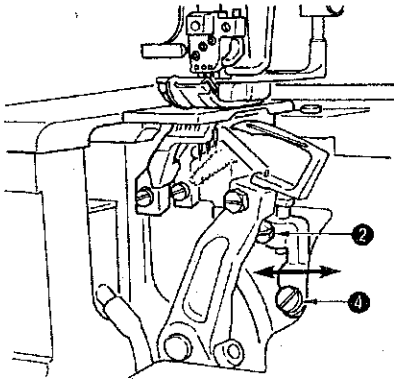
Standard Adjustment	Results of Improper Adjustment
<p>1. Loosen setscrew ④ in the rear needle guard holder and perform the adjustment in the lateral direction.</p>  <p>2. Loosen setscrew ② in the rear needle guard and perform adjustment in the height direction and the direction of rotation.</p> <p>3. After the adjustment, tighten setscrews ② and ④.</p> <p>(Caution) After the adjustment, check by manual turning whether the top end of looper ③ does not come in contact with the needle.</p>	<ul style="list-style-type: none"> ○ When the pressing amount of rear needle guard ① is small, needle deflection increases and stitch skipping, thread breakage, needle breakage and worn-out of the top end of looper ③ will be caused.

(11) Adjusting the needle guard

Standard Adjustment

(4) Timing of the rear needle guard

The standard position of rear needle guard cam ⑤ is the position where timing mark ⑦ in rear needle guard cam ⑤ aligns with the center of the notch of looper longitudinal cam ⑥.

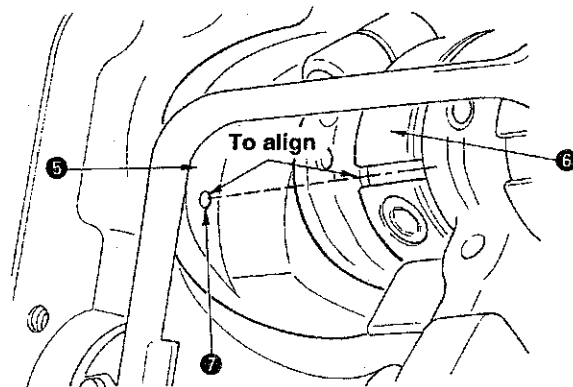

2. Front needle guard

(1) It is the standard that the clearance provided between front needle guard ⑨ and the needle is 0.1 to 0.3 mm.

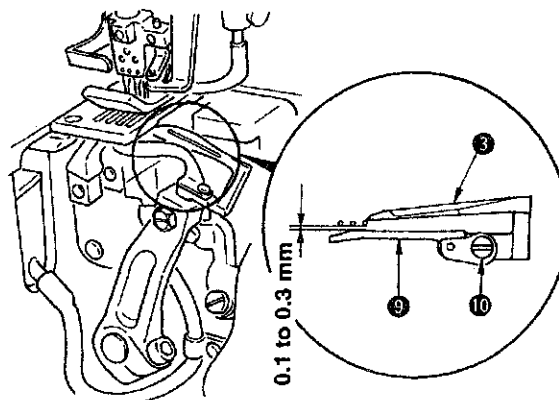

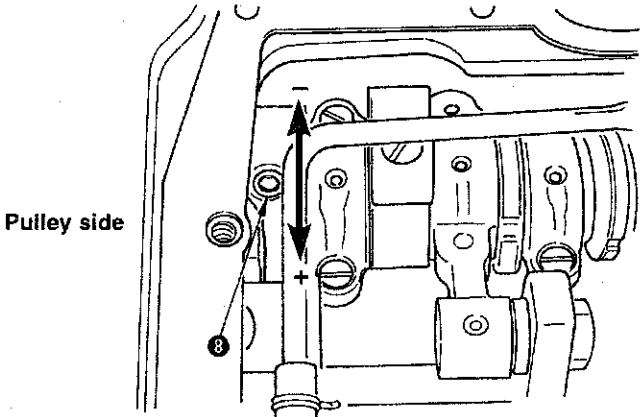
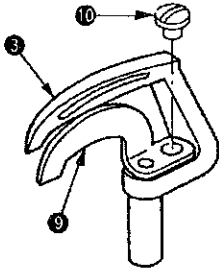
Standard Adjustment	Results of Improper Adjustment
<p>4. Remove the bed top cover. Loosen two setscrews ⑧ in rear needle guard cam ⑤ and adjust the timing. When moving the cam in + direction, timing is advanced, and when moving in - direction, it is retarded.</p> 	<ul style="list-style-type: none"> ○ The cam is excessively changed from the standard position, needle breakage or stitch skipping will be caused.
<p>2. Loosen setscrew ⑩ in the front needle guard and adjust the clearance. Adjust so that the clearance provided between the needle and front needle guard ⑨ is 0.1 to 0.3 mm when looper ③ moves from the extreme right position to the left and passes the rear side of the respective needles and fix the front needle guard with setscrew ⑩. * Place front needle guard ⑨ as near as the needle to such an extent that needle thread passes smoothly in accordance with kind and thickness of thread.</p>  <p>(Caution) Check by manual turning whether the needle is pinched with front needle guard ⑨ and the rear needle guard.</p>	<ul style="list-style-type: none"> ○ When the front needle guard and the needle come excessively near, stitch skipping or needle breakage will be caused.

(12) Instlling cover of the looper and needle guard after adjusting

Standard Adjustment

1. Installing bed top cover ①

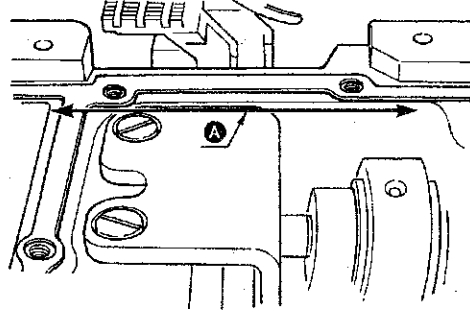
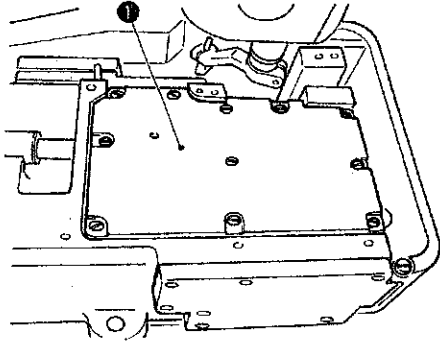

Standard Adjustment	Results of Improper Adjustment
<p>1. When the adjustment of (10) Locus and longitudinal motion of the looper or (11) Adjusting the needle guard has been performed, apply sealant to section A and install bed top cover 1</p>	<ul style="list-style-type: none"> ○ When removing bed top cover 1 for adjustment or the like, sealant is peeled off and oil leakage will be caused.

(13) Adjusting the feed dog

Standard Adjustment

1. Height of the feed dog

It is the standard that the height of feed dogs (main feed dog ② and differential feed dog ④) is 1 mm from the top surface of the throat plate ① when feed dogs ② and ④ are in the highest position.

2. Tilt of the feed dog

It is the standard that the tilt of feed dogs ② and ④ is flush with throat plate ① when feed dogs ② and ④ are in the highest position.

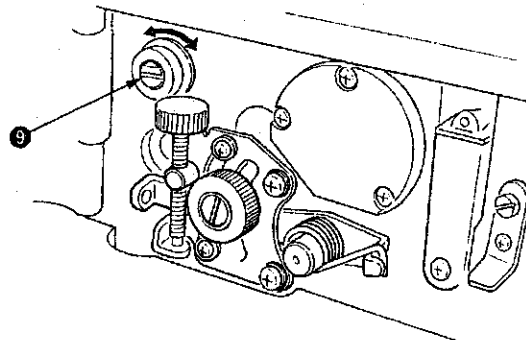
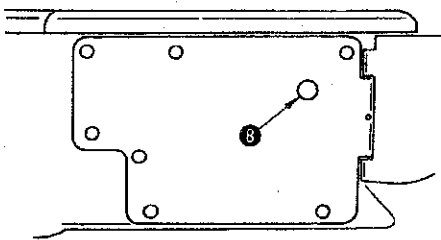
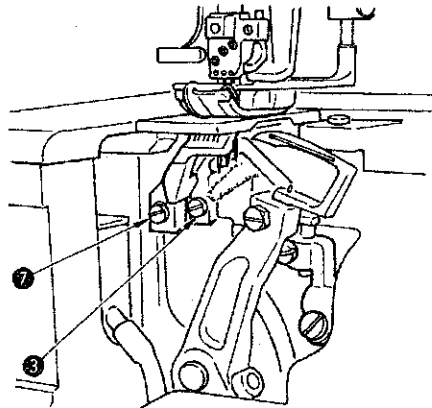
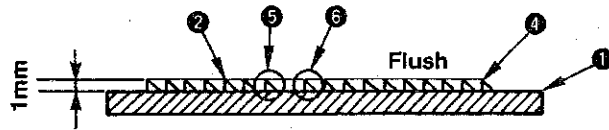

Standard Adjustment	Results of Improper Adjustment
<p>1. Loosen setscrew ⑦ in the differential feed dog and setscrew ③ in the main feed dog, and adjust the height.</p> <p>(1) Adjust the top surface of throat plate ① and the height of the rear end of main feed dog ② to 1 mm when feed dogs ② and ④ come to the highest position, and fix the main feed dog with setscrew ③ in the main feed dog.</p> <p>(2) For the height of differential feed dog ④, adjust the height of front end ⑤ of main feed dog ② and rear end ⑥ of differential feed dog ④, and fix the differential feed dog with setscrew ⑦ in the differential feed dog.</p> <p>2. Adjusting the tilt of the feed dog</p> <p>(1) Remove rubber plug ⑧ in the cover located in the rear of the bed and loosen the setscrew in the feed tilt adjustment shaft located in the rear with a hexagonal wrench key of 2.5 mm.</p> <p>(2) When turning feed dog tilt adjustment shaft ⑨ to the right or left, the top ends of feed dogs ② and ④ move up or down and the tilt of feed dogs ② and ④ can be adjusted.</p> <p>(Caution) After the adjustment check the height of feed dogs ② and ④.</p>	<ul style="list-style-type: none"> ○ When the position of the feed dog is high, stitch skipping, defective chain-off, return of feed, etc. will be caused. Throat plate comes in contact with feed dog and damage of components or abnormal noise will be caused. ○ When the position of the feed dog is low, the stitch length becomes short when the sewing is finished and performance of getting over the overlapped section is deteriorated. ○ When the position of the feed dog is excessively low, looper and feed dog may come in contact with each other. ○ When the tilt of the feed dog is raised toward you, performance of catching material is improved. ○ When the tilt of the feed dog is lowered toward you, it is effective in irregular stitches and puckering.

(13) Adjusting the feed dog

Standard Adjustment

3. Lateral position of the feed dog

It is the standard of the lateral position of the feed dog that the left and right clearances **A** of the feed dog in terms of the slots of the throat plate are parallel and equal.

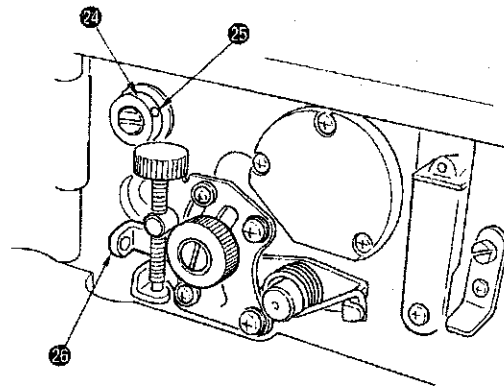
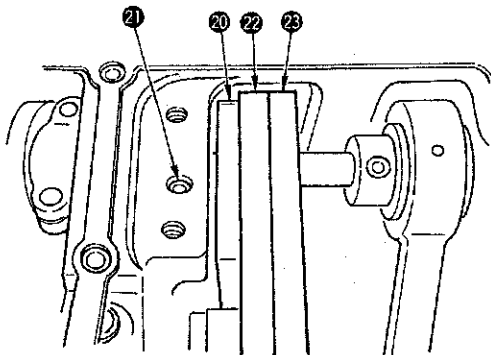
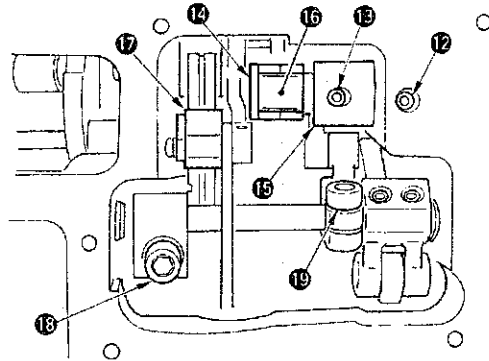
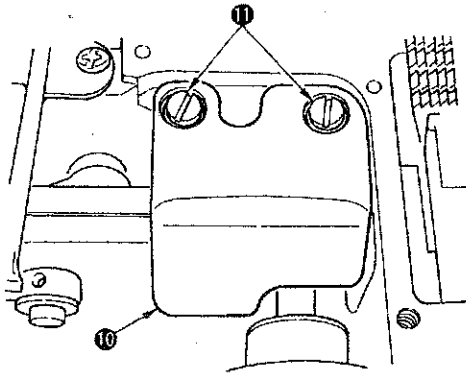
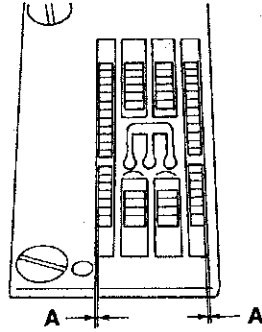

Standard Adjustment	Results of Improper Adjustment
<p>3. Adjusting the lateral position of the feed dog</p> <p>(1) Remove the bed top cover and remove setscrews ① in rocking bar guide 2 ⑩.</p> <p>(Caution) When setting the feed motion amount to 3.6 mm (max.) and the differential feed ratio to 1 : 1 before the adjustment, the adjustment at the time of assembling can be performed with ease.</p> <p>(2) Loosen setscrew ⑫ in the feed tilt adjustment shaft and setscrew ⑬ in the feed tilt eccentric shaft ⑪. Move feed tilt eccentric shaft by approximately 2mm in the left direction shaft, move feed tilt adjustment shaft ⑭ by approximately 2mm in the right direction, and open a clearance to the right and left of square block ⑮.</p> <p>(Caution) When moving feed tilt eccentric shaft ⑪, lower downward differential lever pin ⑰ with differential feed ratio change lever ⑱. Edge of feed tilt eccentric shaft ⑪ comes in contact with the pin and a clearance can not be made.</p> <p>(3) When loosening setscrew ⑲ in the differential feed lever and setscrew ⑳ in the main feed lever, adjustment of the rocking bar in the lateral direction can be performed.</p> <p>(4) Loosen setscrew ㉑ in rocking bar guide 1 ㉒ and adjust main feed rocking bar ㉓ and differential feed rocking bar ㉔ to the right and left so that the clearances of the feed dog in terms of the slots of the throat plate are parallel and equal with feed dog and throat plate attached. When the equal clearances are set, tighten setscrew ㉑ to fix rocking bar guide 1 ㉒, attach rocking bar guide 2 ⑩ and guide setscrews ①, and fix the rocking bar so that it is put between the setscrews.</p> <p>(5) Bring feed tilt adjustment shaft ⑭ and feed tilt eccentric shaft ⑪ to their home positions to get rid of the right and left clearances of square block ⑮.</p> <p>(6) After adjusting the lateral position of the feed dog, loosen setscrew ㉕ in the thrust collar, remove the thrust of the shaft with thrust collar ㉖ and fix the thrust collar with the setscrew.</p> <p>(Caution)</p> <ol style="list-style-type: none"> 1. After fixing, check the lateral play of the rocking bar by moving the feed dog to the right or left. At the same time, move the rocking bar to and fro and check whether it moves smoothly. 2. For the fixing of setscrew ⑲ in the differential feed lever and setscrew ⑳ in the main feed lever, refer to the longitudinal adjustment value of the feed dog. 3. When fixing setscrew ⑫ in the feed tilt adjustment shaft, check the tilt of the feed dog and when fixing setscrew ⑬ in the feed tilt eccentric shaft, there should be no lateral play of square block ⑮. 	<ul style="list-style-type: none"> ○ When the lateral position of the feed dog is incorrect, worn-out of throat plate and feed dog will be caused. ○ Heating or abnormal noise will occur. ○ The feed components will wear out early, or the looseness will be caused.

(13) Adjusting the feed dog

Standard Adjustment

4. Longitudinal position of the feed dog

- (1) Position of the main feed dog : it is the standard that the position where the clearance from the edge of the slot of the throat plate to the front face of the main feed dog is 0.6 ± 0.2 mm at the position where the main feed dog travels to the extreme front position (operator's side) when feed momentum is set to 3.6 mm (maximum).
- (2) Position of the differential feed dog : it is the standard that the position where the clearance provided between main feed dog and differential feed dog is 1.6 ± 0.2 mm when the differential feed ratio is set to 1 : 1 after adjusting the position of the main feed dog.

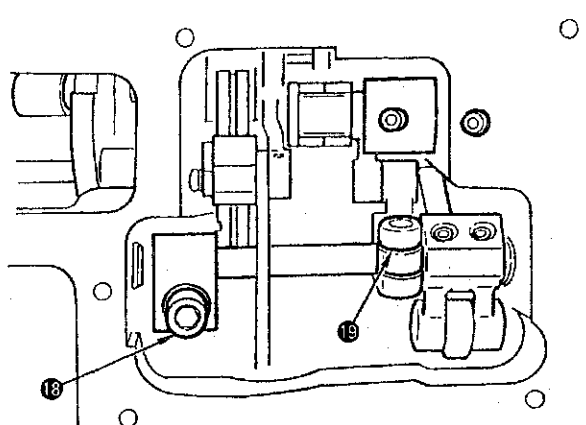
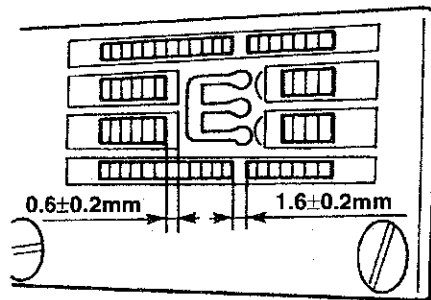

Standard Adjustment	Results of Improper Adjustment
<p>4. Longitudinal position of the feed dog (condition : feed momentum 3.6 mm (maximum))</p> <p>(1) When fixing setscrew ⑨ in the main feed lever, adjust the clearance from the edge of the slot of the throat plate to the front face of the main feed dog to 0.6 ± 0.2 mm when the feed dog travels to the extreme front position (operator's side), press the main feed lever to the rocking bar side, and fix it with setscrew.</p> <p>(2) When fixing setscrew ⑩ in the differential feed lever, set the differential feed ratio to 1 : 1, adjust the clearance provided between the main feed dog and the differential feed dog to 1.6 ± 0.2 mm, press the differential feed lever to the rocking bar side, and fix it with setscrew.</p> <p>(Caution) When the adjustment value changes greatly, feed dog or throat plate will be broken.</p>	<ul style="list-style-type: none"> ○ When the fixing position of the main feed lever slips greatly out of position, abnormal noise or abrasion will be caused. ○ When the fixing position of the differential feed lever slips greatly out of position, abnormal noise or abrasion will be caused.

Standard Adjustment	Results of Improper Adjustment
<p>1. When making the stitch length more than 3.6 mm, loosen setscrew ② of the feed adjustment stopper pin, turn feed adjust knob ① clockwise, and adjust the stitch length. By turning feed adjust knob ①, pin ③ is pushed out. Fix pin ③ with setscrew ② in the feed adjustment stopper pin after adjusting the stitch length. Maximum stitch length is 4.4 mm.</p> <p>2. Loosen lock nut ④ and raise release lever ⑤ to increase the differential feed ratio, and lower it to decrease the differential feed ratio. Fine adjustment of the differential feed ratio can be performed with micro-adjust knob ⑥. When engraved marker ⑦ of the differential feed lever is aligned with the long engraved marker line on the dial plate, the momentum of the main feed dog and the differential feed dog becomes almost 1 : 1.</p>	<ul style="list-style-type: none"> ○ When the stitch length is set to more than 3.6 mm, the contact of main feed dog, differential feed dog and throat plate occurs due to the adjustment in case of the standard position of the feed dog. Additionally machine the feed dog to satisfy the need. ○ When using the machine with the stitch length of more than 2.5 mm and the maximum differential feed ratio, turn the machine by hand and check whether there is any contact with feed dog and throat plate. In addition, when more gathering is necessary, grind the differential feed dog.

(15) Adjusting the presser foot

Standard Adjustment

1. Height of the presser foot

Height of the presser foot has to be the position the presser foot does not come in contact with other components at the position where lifter lever ❶ is lowered and comes in contact with height adjustment screw ❸.

Dimension A

8 mm in case of needle gauge 5.6 mm without top covering

5 mm in case of needle gauge 5.6 mm with top covering

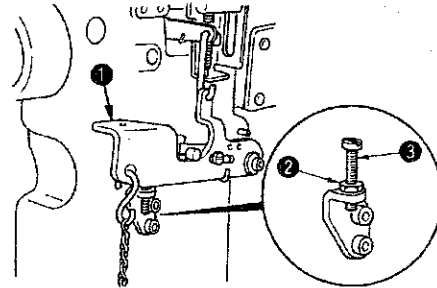

2. Position of the thrust collar

(1) Clearance provided between thrust collar ❹ and presser shaft bushing ❷ is 0.1 mm at the position where lifter lever ❶ is lowered and comes in contact with height adjustment screw ❸.

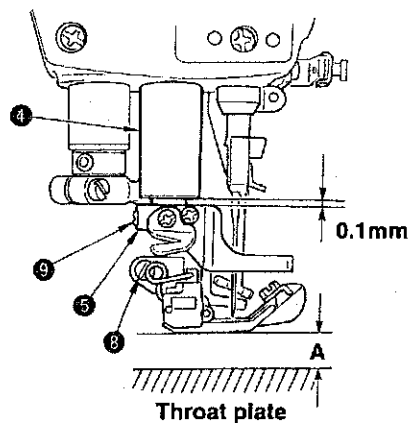

3. Position of the lifter connecting plate

(1) Adjust the clearance provided between lifter connecting plate ❸ and hinge screw ❹ to 0.5 mm when the presser foot is lowered in the state that the feed dog comes down below the throat plate.

(2) Adjust so that the needle enters in the center of needle entry of the presser foot and fix the presser foot with setscrew ❺ in the presser bracket.

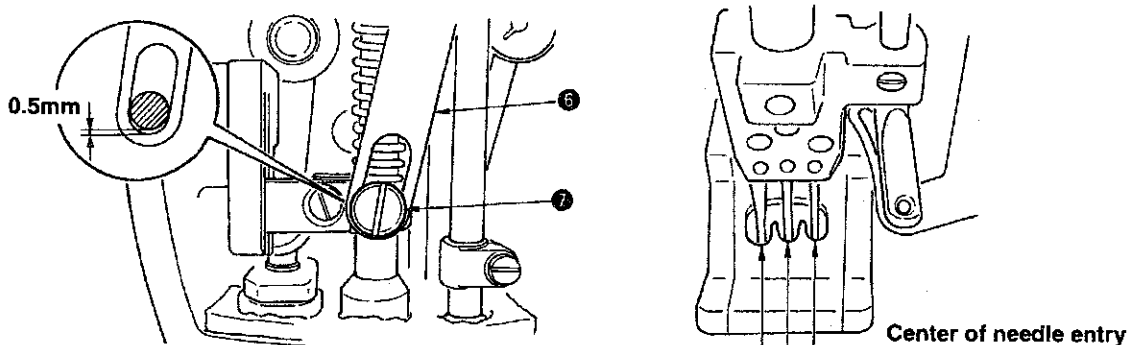

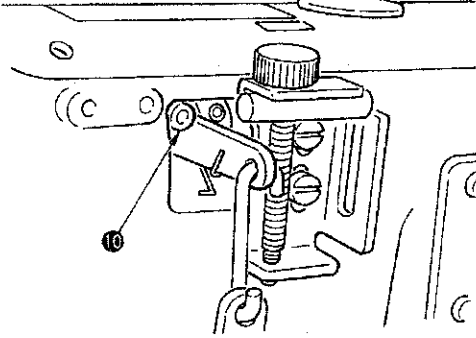
Standard Adjustment	Results of Improper Adjustment
<p>1. Adjusting the height of the presser foot Loosen adjustment nut ②. Lower lifter lever ①, adjust height adjustment screw ③, and fix nut ④ at the position where the presser foot does not come in contact with other components.</p> <p>2. Adjusting the thrust collar Loosen setscrew ⑨ in the thrust collar and adjust the clearance. When the height of the presser foot is changed, Be sure to perform the adjustment of the clearance of thrust collar ⑤ and check the clearance.</p> <p>3. Adjusting the lifter connecting plate For the adjustment of the clearance provided between lifter connecting plate ⑥ and hinge screw ⑦, loosen setscrew ⑩ in the lifter lever shaft when the feed dog lowers from the top surface of the throat plate and the bottom face of the presser foot comes in close contact with the throat plate.</p>	<ul style="list-style-type: none"> ○ When the position of the presser foot is too high, it comes in contact with the spreader, and breakage, stitch skipping, etc., will be caused. In addition, the needle tip comes out from the sole of the presser foot. As a result, sewing material is damaged or needle breakage will be caused. ○ In case the clearance of thrust collar ⑤ is large, when the presser foot gets over the overlapped section, the presser foot comes in contact with other components and will cause the damage. ○ When replacing the presser foot due to the replacement of the gauge or the like, check the clearance provided between thrust collar ⑤ and lifter connecting plate ⑥. ○ When the clearance of lifter connecting plate ⑥ does not exist, not only feed force is reduced but also components are led to breakage since the presser foot does not come down to the top surface of the throat plate when the feed dog comes down from the top surface of the throat plate. ○ When adjusting the lever shaft, adjust the height of lifter lever ①.
	

(16) Adjusting the micro-lifter

Standard Adjustment

1. Micro-lifter

Adjust the micro-lifter in accordance with sewing conditions for use.

Major applicable process

1. When twist occurs in the hemming bottom process.
2. When tape is twisted in collarette.

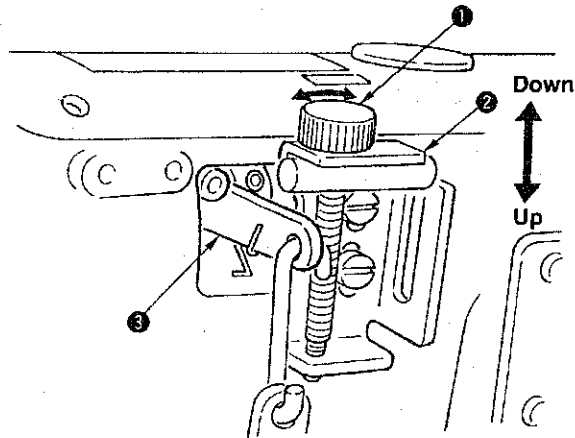

Standard Adjustment	Results of Improper Adjustment
<p>1. Adjusting the micro-lifter</p> <p>(1) When micro-lifter knob ❶ is turned counterclockwise, micro-lifter stopper ❷ lowers and comes in contact with presser lifting lever ❸. Then the presser foot goes up. Adjust the height according to the sewing conditions.</p> <p>(2) When micro-lifter knob ❶ is turned clockwise, micro-lifter stopper ❷ is raised and comes in contact with presser lifting lever ❸. Then the presser foot comes down.</p> <p>(Caution) When the micro-lifter is not used, turn clockwise micro-lifter knob ❶ and fix micro-lifter stopper ❷ at the highest position.</p>	

(17) Adjusting the looper thread cam

Standard Adjustment

1. Adjust so that thread comes off from the highest place of looper thread cam ② when needles come down and the top end of left needle ③ aligns with the bottom surface of looper ④. Then tighten setscrews ① to fix the looper thread cam.

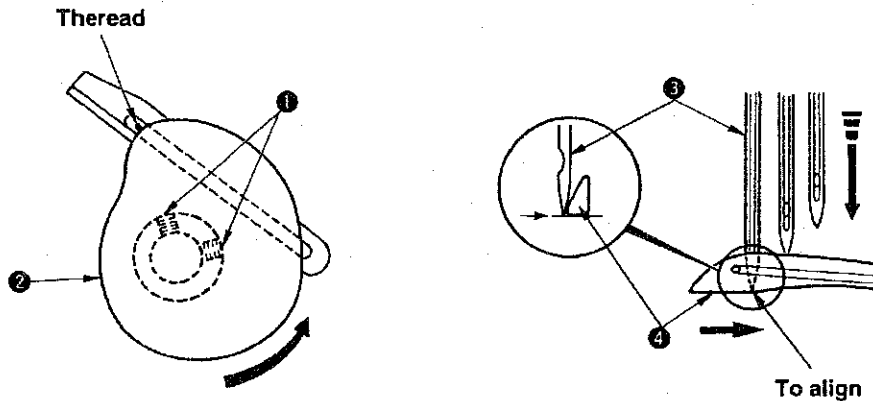

2. Preventing thread winding around the looper thread cam

Adjust the clearance provided between the top end of section A of looper thread winding prevention plate ⑤ and the edge of looper thread cam ② to approximately 0 to 0.3 mm (the plate should not come in contact with looper thread cam ②).

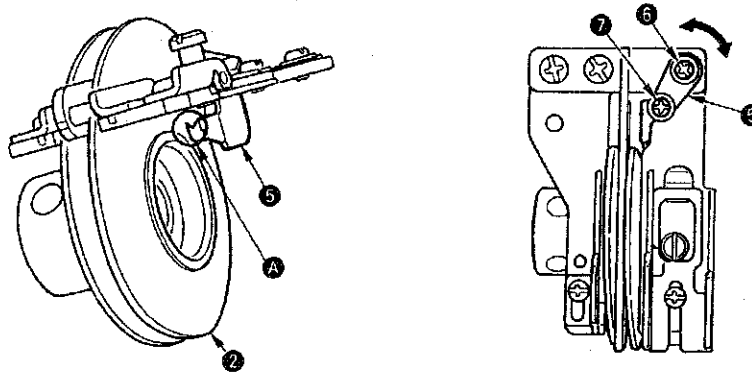

Standard Adjustment	Results of Improper Adjustment
<p>1. Loosen setscrews ❶ in the looper thread cam ❷ and adjust while checking that looper thread comes off from the periphery of the looper thread cam.</p> <p>(Caution) When setscrews ❶ in the looper thread cam are loosened, looper thread cam ❷ moves in the shaft direction as well. Assemble so that the clearances provided between the cam and the thread guide are equal.</p> <div data-bbox="475 632 822 999" data-label="Image"> </div> <p>2. Adjusting the looper thread winding prevention plate Adjust the clearance provided between the top end of section A of looper thread winding prevention plate ❸ and the edge of looper thread cam ❷ to approximately 0 to 0.3 mm (looper thread winding prevention plate ❸ has a slot at the section of setscrew ❹ and moves as if it rotates making setscrew ❺ as the center), and tighten setscrews ❹ and ❺ to fix the looper thread winding prevention plate.</p>	<ul style="list-style-type: none"> ○ When the position of looper thread cam ❷ slips greatly out of position, stitch skipping or defect of thread tightness on the back of the looper ❹ is apt to occur. ○ It is effective to adjust as narrow as possible the clearance provided between the top end of click section (section A) of looper thread winding prevention plate ❸ and the edge of looper thread cam ❷. However, when making them come too near and come in contact with each other, looper thread cam ❷ is scratched and winding is caused by this adjustment, instead.

(18) How to change needle bar stroke

Standard Adjustment

1. Changing the needle bar stroke (31 mm → 33 mm)

Needle bar stroke is 31 mm in the state that notch mark ④ on the edge of the eccentric pin ⑤ is located on the side of the center of main shaft (standard delivery adjustment).

At the time of 31 mm

At the time of 31 mm

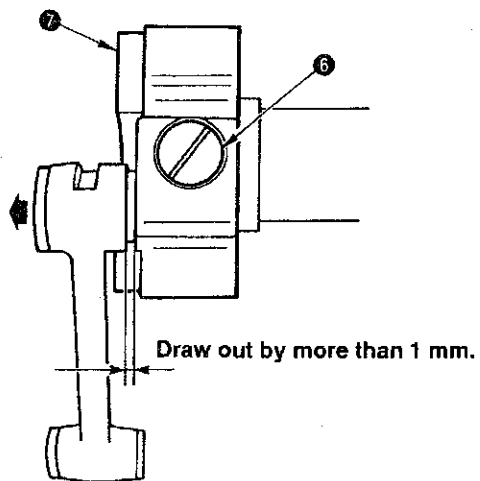
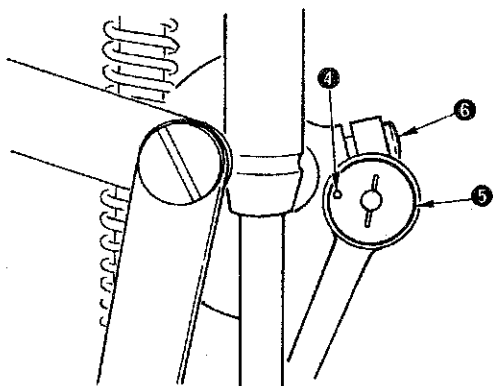

At the time of 33 mm

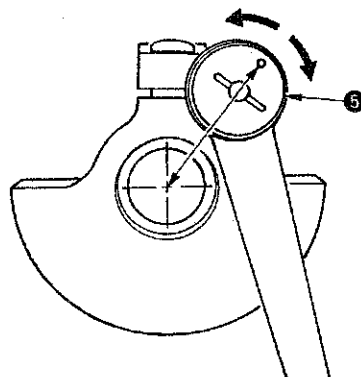

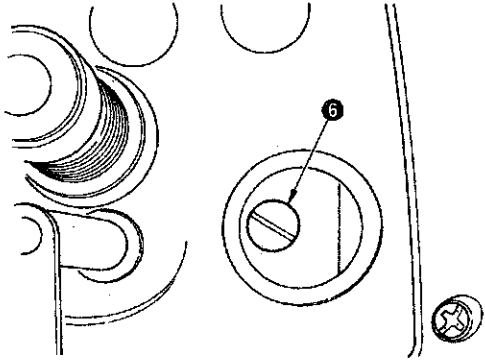
Standard Adjustment	Results of Improper Adjustment
<p>1. Changing the needle bar stroke</p> <p>(1) Loosen setscrew ⑥ (remove the rubber plug) in eccentric pin ⑤.</p>  <p>(2) Draw out eccentric pin ⑤ by more than 1 mm, turn eccentric pin ⑤ by 180°, position notch mark ④ of the eccentric pin away from the center of main shaft, push the pin, and fix the pin with setscrew ⑥.</p> <p>* Position of the notch mark of eccentric pin At the time of needle bar stroke 31 mm : notch mark is on the side of the center of main shaft. At the time of needle bar stroke 33 mm : notch mark is on the side away from the center of main shaft.</p> <p>(Caution) There is a groove to fit, when eccentric pin ⑤ is turned by 180°, at the fitting section of eccentric pin ⑤ and counter weight ⑦. After the change, check that the pin has completely entered the groove. At the same time, check whether eccentric pin ⑤ has completely entered up to the end. When the pin is excessively pressed, abnormal noise or worn-up will be caused.</p>	<ul style="list-style-type: none"> ○ In case of the thick materials, the stroke is changed. However, basically, use the machine with the standard stroke. ○ When the needle bar stroke is increased, needle heat or sewing trouble may occur. ○ When the needle bar stroke is increased, reduce the sewing speed for use. <p>Good result is obtained from the viewpoint of durability.</p>

(18) How to change Needle bar stroke

Standard Adjustment

2. Adjusting the height of the needle bar

When the needle bar stroke is changed, be sure to adjust the height of the needle bar.

- 1) Adjust clearances **C** provided between needles **8** and needle holes **9** in the throat plate to equal.
- 2) Adjust the height of the needle bar so that the top end of the needle eyelet of left needle aligns with the bottom end of the looper when the looper moves from the extreme right position to the left and top end **D** of looper **3** protrudes by approximately 1 mm from the left end of left needle, remove rubber cap **4** in the face plate, and tighten the needle bar with setscrew **10** in the needle bar bracket.

Reference : When the needle is in the highest position, height **E** from top surface **A** of the throat plate to the top end of left needle is as shown in the table below.

Unit : mm

2-needle		3-needle	
Needle gauge	Height of left needle E	Needle gauge	Height of left needle E
3.2	11.1	—	—
4.0	10.7	—	—
4.8	10.2	4.8	10.2
5.6	9.9	5.6	9.9
6.4	8.8	6.4	8.8

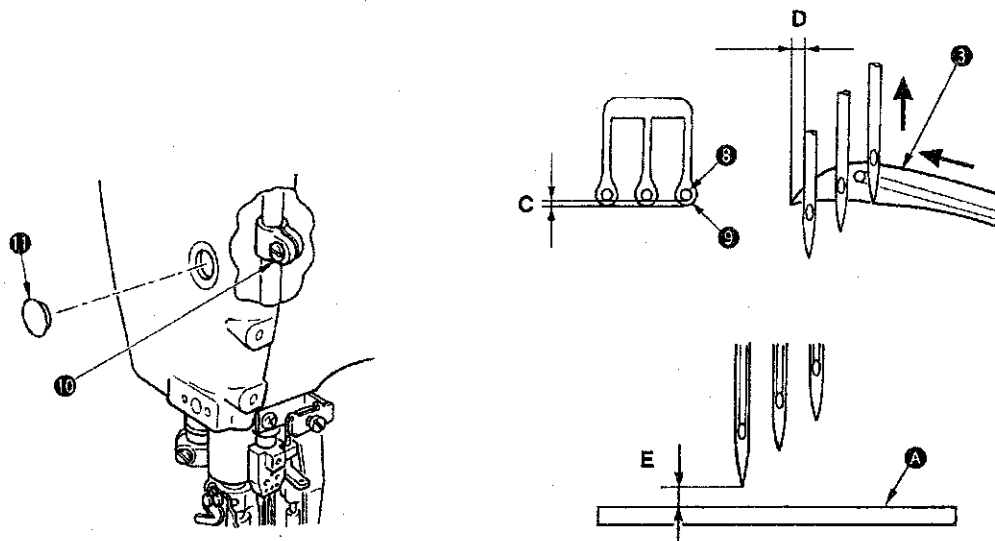

3. Adjusting the needle guard

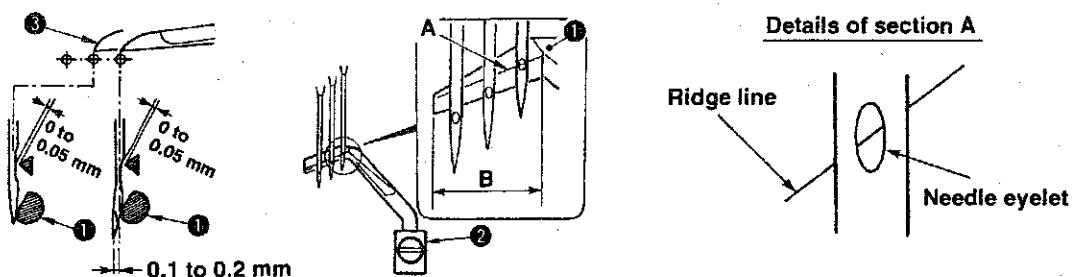

Standard Adjustment	Results of Improper Adjustment
<p>(1) Loosen setscrew ⑩ in the needle bar bracket and adjust the height of the needle bar.</p> <p>(2) After adjusting the height of the needle bar, adjust clearances C provided between needles ⑧ and needle holes ⑨ in the throat plate to equal and fix the needle bar with setscrew ⑦.</p> <p>* Refer to 5.- (9) Height of the needle.</p> <p>1. Standard position of the rear needle guard It is the standard that the lateral position of rear needle guard ① is the position where the rear needle guard receives the needle in the range of B in the illustration.</p> <p>2. It is the standard that the ridge line of rear needle guard ① enters in the eyelet of right needle (section A) when the needle bar is in the lowest position.</p> <p>3. When the top end of looper ③ comes from the extreme right position to the center of right needle, the clearance provided between the right needle and the top end of looper ③ becomes 0 to 0.05 mm and the pressing amount of the top end of the needle becomes 0.1 to 0.2 mm. It is the standard for the middle needle that when the top end of looper ③ comes to the center of middle needle, the clearance provided between middle needle and the top end of looper ③ becomes 0 to 0.05 mm and the pressing amount of the top end of needle is such an amount that the rear needle guard touches the middle needle.</p> <p>* For the details, refer to the standard adjustment procedure in 5.- (11) Adjusting the needle guard.</p>	<ul style="list-style-type: none"> ○ When the position of the height of the needle bar is excessively different, stitch skipping, needle breakage, thread breakage, etc. will be caused. ○ When the adjustment value is excessively different from the specified value, needle breakage or stitch skipping will be caused.

(19) How to change the spreader

Standard Adjustment

1. Changing the spreader

When the needle bar stroke is changed, be sure to perform the adjustment of (6) -1. the height of the spreader.

(1). Height from the top surface of throat plate ② to spreader ① is 10.0 to 10.5 mm.

(2). Clearance provided between spreader ① and spreader thread guide ③ is 0.4 to 1.0 mm.

(3). Clearance provided between spreader thread guide ③ and needle clamp thread guide ④ is 0.8 to 1.2 mm.

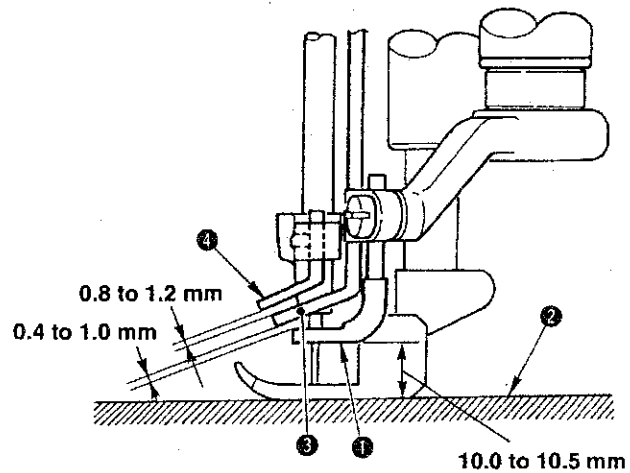

Standard Adjustment	Results of Improper Adjustment
1. Refer to (6) Adjusting the spreader.	

(20) With regard to lubrication

Standard Adjustment

1. Replacing the oil filter

Normal lubrication cannot be performed if dust collects in oil filter ❶.

Inspect it every 6 months.

2. Oil circulation identification window

Make sure that lubricating oil rises to oil circulation identification window ❸ during operation.

<When using the sewing machine for the first time>

Lubricating oil has been taken out at the time of delivery. Be sure to supply lubricating oil before using the sewing machine for the first time.

- Oil used : JUKI MACHINE OIL 18

(Caution) Do not use oil addition agent since deterioration of lubricating oil or machine trouble will be caused.

Remove oil hole cap ❶ on which "OIL" is indicated and fill the oil reservoir with lubricating oil up to the level between the upper and lower engraved marker lines of oil gauge ❷.

<Checking before using the sewing machine>

- 1) Check oil gauge ❷ and make sure that lubricating oil level is between the upper and lower two lines. When lubricating oil level lowers below the lower line, supply lubricating oil.
- 2) Make sure that lubricating oil comes out from the nozzle of oil circulation identification window ❹ when rotating the sewing machine. When lubricating oil does not come out, perform "Inspecting and replacing the oil filter ❶".

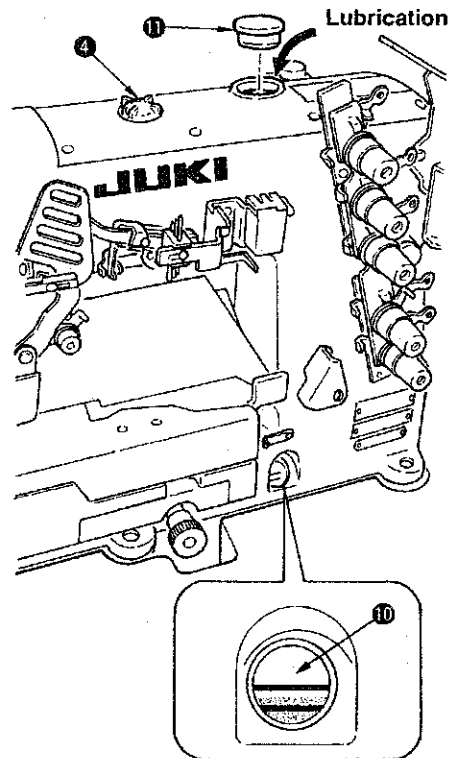
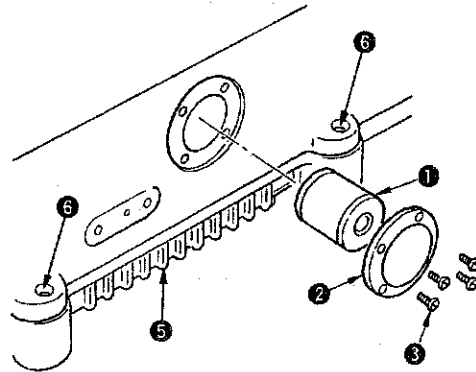

Standard Adjustment

1. Inspection and replacement

Loosen setscrews ③ in the oil filter cap and remove oil filter cap ②. Draw out oil filter ① to inspect it. When it is clogged with dust, replace it with a new one.

After the replacement, fix oil filter cap ② with setscrews ③ in the oil filter cap.

(Caution) When removing the oil filter cap ②, lubricating oil collected in oil filter ① will leak out. So, be careful.

2. Oil circulation identification

(1) In case the oil does not come out from oil circulation identification window ④ even when oil filter ① is replaced with a new one, remove six setscrews ⑥ in the oil pan, remove oil pan ⑤, and tilt the machine head to the rear up to the position where pipe connecting joint screw ⑨ can be removed.

(2) Oil sucked up from gear pump ⑦ passes oil pipe ⑧ and enters oil filter ① from pipe connecting joint screw ⑨. When the lubricating oil does not rise to oil circulation identification window ④, The hole in pipe connecting joint screw ⑨ may be clogged with dust. So, check it.

(Caution) When there is any foreign material in oil pan ⑤, remove it.

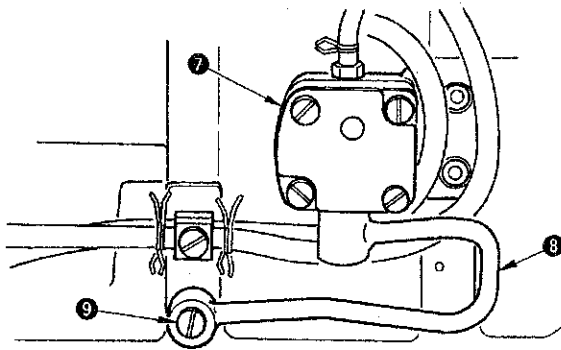

Results of Improper Adjustment

- In case oil cannot be observed from oil circulation identification window ④ even when the sewing speed is 2,500 rpm or over, the machine will be in danger of seizure if the operation is continued.

(21) Adjusting and setting SC-380

1. When SC-380 is used, install the motor referring to the Instruction Manual for SC-380.
2. To use SC-380 with MF-7700, it is necessary to set the followings after set-up of SC-380.

(Caution) When MF is selected in case of machine model selection, change the direction of rotation since the direction of rotation of MF-7700 becomes reverse. In addition, there is the possibility that the pulley rotates up to the home position at the time of turning ON the power.

○ Change over the setting of SC-380 to MF-7700

(When changing, refer to the Instruction Manual for SC-380 as well)

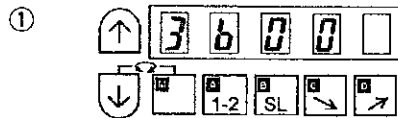

* Program mode (2) Model selection

Select MF with $\downarrow + [C] + [D]$, and keep pressing $[D]$ for more than two seconds to return to the normal mode. (When the thread trimmer is not installed, proceed to ② C mode Thread trimmer safety switch release to release the safety switch since LED.M does not rotate.)

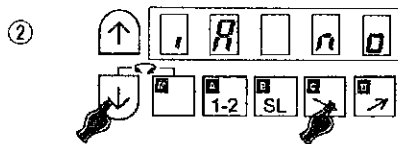

* C mode Thread trimmer safety switch release

(Setting when thread trimmer is not used)

IA S6 is displayed with $\downarrow + [C]$. Set IA S6 to IA NO.

Screen returns to the normal mode with $\downarrow + \uparrow$.

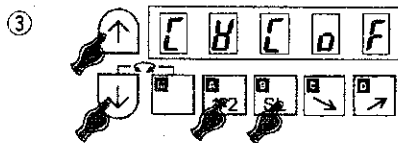

* Prohibition function of J mode direction of rotation changeover

$\downarrow + \uparrow + A + B$ CWC ON \rightarrow OFF

Screen returns to the normal mode with $\downarrow + \uparrow$.

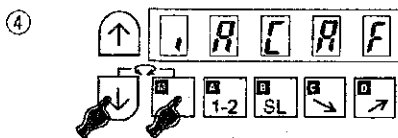

* Change of the direction of rotation

Set the direction of rotation to the clockwise rotation with $\downarrow + [M]$.

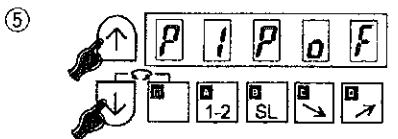

* Operating function of P mode when power is turned ON

When 1-position is set: $\downarrow + \uparrow$ P1P ON \rightarrow OFF

When 2-position is set: $\downarrow + \uparrow$ P2P ON \rightarrow OFF

Screen returns to the normal mode with $\downarrow + \uparrow$.

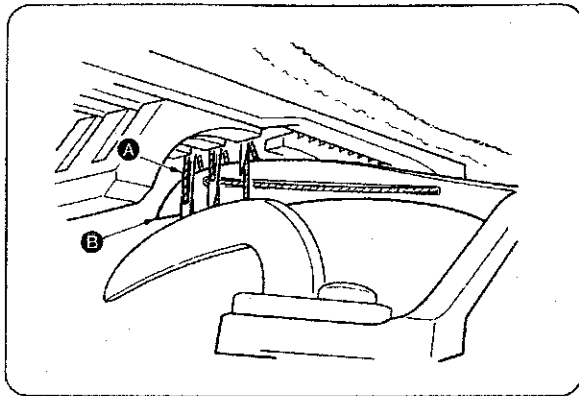

3. Adjusting the position detector of SC-380

- 1) When using the position detector for MF-7700, change DOWN position of the needle and adjust DOWN position of the position detector so that the needle stops after the top end of looper B has scooped left needle thread A as shown in the figure.

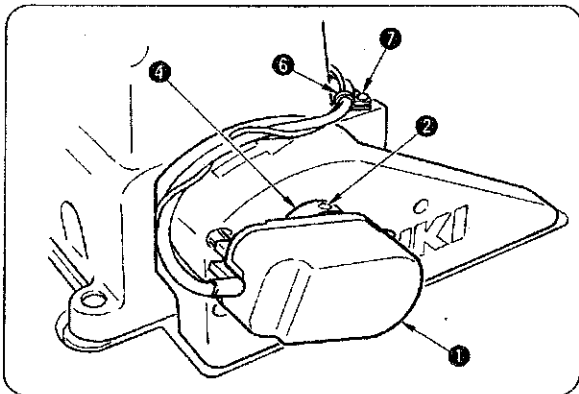

4. Adjusting procedure

In the state that the position detector is actually installed on the sewing machine, adjust the stopping position.

- 1) Temporarily install detector 1 onto the lower pulley with setscrews 2.
- 2) Wind the ground wire (green/yellow) around the cord of detector 1, connect the ground wire to the ground mark in the rear of the sewing machine head, and fix the cord of the detector at the position in the figure with cord clamp 6 and setscrew 7 supplied with the machine.
- 3) Connect the connector of detector 1 to the connector of detector of SC-380 control box. Turn ON the power, set the sewing machine controller to 1 position setting (needle UP position stop) and lightly depress the pedal to operate the sewing machine by 2 to 3 stitches. Then turn OFF the power at the position where the sewing machine has stopped. Loosen setscrews 2 in detector 1, turn the upper pulley with joint 4 fixed, and adjust the stopping position. Fix detector 1 with setscrews 2.
- 4) Remove the cover of detector 1 and adjust the red mark ▼ 5 on the outside of DOWN position detector plate 3 to 11 to 12 of the scale (inside DOWN position detector plate).
- 5) After adjustment of stopping position, replace the cover of detector 1.
- 6) Turn ON the power again, and set the sewing machine controller to 2 position setting.

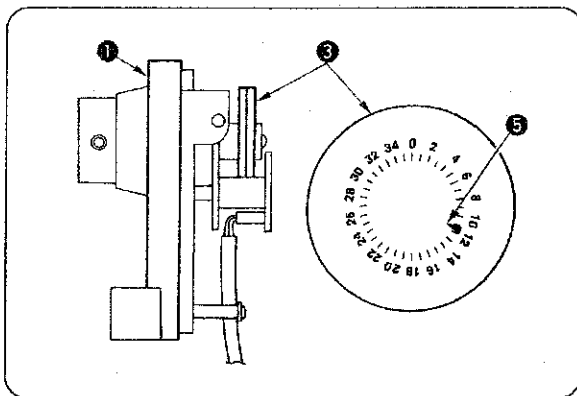

6. TROUBLES AND CORRECTIVE MEASURES

Troubles	Cause (1)	Cause (2)	Corrective measures
1. Thread breakage	1-1) Threading	1-A) Thread caught in thread guide, incorrect threading	Refer to threading diagram.
	1-2) Thread path	2-A) Resistance produced by flaw, burr, rust etc. around needle entry of throat plate, stitch tongue, looper, spreader, needle thread take-up auxiliary thread tension adjustment, needle guide, thread tension disc etc.	Remove the flaw, burr etc. and process the thread guide finish. However, replace such important parts as looper or throat plate etc. with the new part because their shape is changed by being processed.
	1-3) Needle guard	3-A) Strong contact of needle against needle guard produces a sharp edge in needle guard resulting in thread breakage.	In case needle exchanger, or looper needle guard is worn out, replace it with the new part.
	1-4) Needle	4-A) Too thin needle for the thread used	Replace it with an appropriate needle.
	1-5) Needle heat	5-A) Needle is heated depending on fabric type, number of fabrics, sewing speed resulting in thread breakage.	Use thinner needle. Reduce the sewing speed. Use silicon oil lubricant device.
	1-6) Thread	6-A) Poor quality and weakness of thread	Replace it with the thread of good quality.
	1-7) Thread tension	7-A) Too strong thread tension	Reduce thread tension. needle thread guide rod is positioned too high making the thread tension too strong.
	1-8) Interference	8-A) Interference with feed dog, throat plate due to the incorrect mounting height of looper	Mount it in the correct position.
	1-9) Chain-off thread defect	9-A) Flaw produced in stitch tongue in throat plate, feed dog, tongue in presser foot, underside in presser foot	Remove the flaw, burr etc.
2. Looper thread breakage	2-1) Thread guide	1-A) Resistance produced by flaw, burr, rust etc. in stitch tongue in throat plate, looper, looper thread cam, thread guide, thread tension disc	Remove the flaw, burr etc. and process the thread guide finish. However, replace such parts as looper with the new part because its shape is changed by being processed.
	2-2) Looper thread cam adjustment	2-A) Excessive tension applied due to the incorrect position of looper thread cam timing, thread guide	Refer to the standard adjustment figures.
	2-3) Thread tension	3-A) Too strong tension of looper thread	Reduce the thread tension while checking to see the tension balance against the needle thread, top covering thread.

To the next page

Troubles	Cause (1)	Cause (2)	Corrective measures
From the previous page	2-4) Thread	4-A) Poor quality and weakness of thread	Replace it with good quality of thread.
	2-5) Loper avoid	5-A) Too strong contact of looper back with needle resulting in thread breakage	Adjust longitudinal momentum of the looper and make the looper contact the needle at 1/3 height from the bottom surface of the back of looper.
	2-6) Needle heat	6-A) In case needle heat is generated looper thread's contact with needle causes thread breakage, specially at the time machine is at rest.	Refer to needle heat in needle breakage
3. Needle breakage	3-1) Needle entry	1-A) Needle hits the throat plate or presser foot because the needle entry is not correctly positioned for the plate or foot.	Align the needle entry to the needle.
	3-2) Spreader	2-A) Too little clearance between spreader and needle	Refer to the standard adjustment figures.
	3-3) Interference of looper with scooping movement of needle	3-A) Needle hits looper resulting in needle breakage.	Make adjustment so that looper does not hit the looper. For the correction of the contact at looper's back, adjust the moving amount, front and rear.
	3-4) Needle guard	4-A) Too strong contact against needle guard or needle point hits needle guard due to incorrect position.	Refer to the standard adjustment figures.
	3-5) Needle thickness No.	5-A) Too thin needle for fabric used	Use thicker needle.
	3-6) Thread tension	6-A) Needle thread tension is too strong.	Reduce the needle thread tension.
	3-7) Feed height, Needle height	7-A) Feed dog is too high or needle height is too low resulting in needle breakage due to needle swerve.	Refer to the standard adjustment figures.
4. Worn out needle point	4-1) Needle guard	1-A) Incorrect height or incorrect position, front and rear	Check to see the height of needle guard and clearance between needle guard and needle.
	4-2) Interference with looper	2-A) Moving amount, front and rear is ill balanced.	Adjust moving amount, front and rear and correct the incorrect position of looper's back and the contact when it returns.

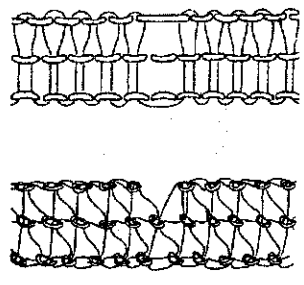
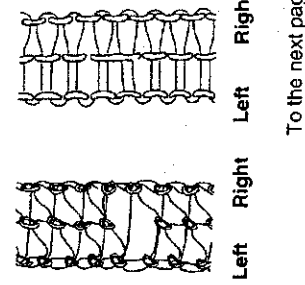

Troubles (1)	Troubles (2)	Cause (1)	Cause (2)	Corrective measures
5. Stitch skipping	5-1) Looper does not scoop the right needle thread. 	1-A) Looper 1-B) Needle 1-C) Auxiliary thread tension adjustment 1-D) Needle thread guide rod 1-E) Needle height 1-F) Threading 1-G) Needle guard 1-H) Spreader 1-I) Needle heat 1-J) Looper adjustment 1-K) Needle guard, front and rear	A-1) Incorrect shape of pointed end of looper disables scooping a loop. B-1) Needle bend, incorrect needle mounting direction, wrong needle C-1) Not used. D-1) Too high E-1) Needle bar position is too high. F-1) Incorrect threading G-1) Not used. H-1) Spreader thread tension is too strong. I-1) Stitch skip occurs before thread breakage produced by needle heat. J-1) Incorrect clearance adjustment, incorrect returning amount adjustment K-1) Incorrect contact amount, incorrect height	Replace it with the genuine part. Replace the needle with new one, Correct the mounting direction, Use UY128GAS. Use nipper. Correct the height to appropriate height. Refer to the standard adjustment figures. Refer to threading diagram. Use needle guard. Reduce the tension. Same described in page " Thread breakage by needle heat" Refer to standard adjustment. Refer to the standard adjustment figures.
	5-2) Looper does not scoop the middle needle thread. 	2-A) Looper 2-B) Needle 2-C) Auxiliary thread tension adjustment 2-D) Needle thread guide rod 2-E) Needle height 2-F) Threading	A-1) Incorrect shape of pointed end of looper disables scooping a loop. B-1) Needle bend, incorrect needle mounting direction, wrong needle C-1) Being used. D-1) Height is too low. E-1) Needle bar height is too low. F-1) Incorrect threading	Replace it with the genuine part. Replace the needle with new one, Correct the mounting direction, Use UY128GAS. Do not use nipper. Correct height position to appropriate height. Refer to the standard adjustment figures. Refer to threading diagram.

To the next page

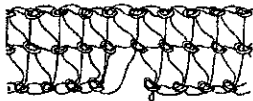
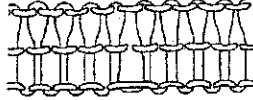
To the next page

Troubles (1)	Cause (1)	Cause (2)	Corrective measures
From the previous page	2-G) Needle thread guard	G-1) Being used.	Do not use.
From the previous page	2-H) Spreader	H-1) Spreader thread tension is too strong.	Reduce the tension.
From the previous page	2-I) Needle heat	I-1) Stitch skip occurs before thread breakage produced by needle heat.	Same described in page "Thread breakage by needle heat"
From the previous page	2-J) Looper adjustment	J-1) Incorrect clearance adjustment, incorrect returning amount adjustment	Refer to the standard adjustment figures.
From the previous page	2-K) Needle guard, front and rear	K-1) Incorrect contact amount, incorrect height	Refer to the standard adjustment figures.
From the previous page	3-A) Looper	A-1) Incorrect shape of pointed end of looper disables scooping a loop.	Replace it with the genuine part.
From the previous page	3-B) Needle	B-1) Needle bend, incorrect needle mounting direction, wrong needle	Replace the needle with new one, Correct the mounting direction, Use UY128GAS.
From the previous page	3-C) Auxiliary thread tension adjustment	C-1) Being used.	Do not use nipper.
From the previous page	3-D) Needle thread guide rod	D-1) Height is too low.	Correct height position to appropriate height.
From the previous page	3-E) Needle height	E-1) Height is too low.	Refer to standard adjustment.
From the previous page	3-F) Threading	F-1) Incorrect threading	Refer to threading diagram.
From the previous page	3-G) Needle guard	G-1) Being used.	Do not use.
From the previous page	3-H) Spreader	H-1) Too near to the left needle	Refer to the standard adjustment figures.
From the previous page	3-I) Needle heat	I-1) Stitch skip occurs before thread breakage produced by needle heat.	Same described in page "Thread breakage by needle heat"
From the previous page	3-J) Looper adjustment	J-1) Incorrect clearance adjustment, incorrect returning amount	Refer to the standard adjustment figures.
From the previous page	3-K) Needle guard, front and rear	K-1) Incorrect contact amount, incorrect height	Refer to the standard adjustment figures.
From the previous page	5-3) Looper does not scoop the left needle thread.		
From the previous page			
From the previous page	Left Right	Left Right	

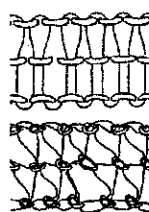
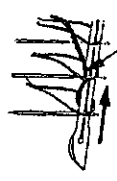
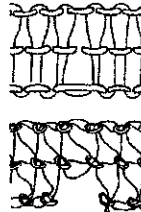
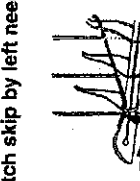
To the next page

Troubles (1)	Troubles (2)	Cause (1)	Cause (2)	Corrective measures
From the previous page	5-4) Needle does not scoop the looper thread. (Triangle stitch skip) Middle needle Left needle	4-A) Looper	A-1) Ventral shape is incorrect.	Replace it with the genuine part.
	4-B) Needle 4-C) Needle height 4-D) Threading	B-1) Needle bend C-1) Needle bar position is too high. D-1) Incorrect threading	B-1) Needle bend C-1) Needle bar position is too high. D-1) Incorrect threading	Replace the needle with the new one. Refer to the standard adjustment figures. Refer to threading diagram.
Stitch skip by middle needle 	4-E) Looper adjustment	E-1) incorrect clearance adjustment, incorrect returning amount	E-1) incorrect clearance adjustment, incorrect returning amount	Refer to the standard adjustment figures.
Slack of looper thread 	4-F) Looper thread tension	F-1) Tension is too weak.	F-1) Tension is too weak.	Increase tension.
Stitch skip by left needle 	4-G) Looper thread cam timing	G-1) Looper thread cam timing is too	G-1) Looper thread cam timing is too	Refer to the standard adjustment figures.
Slack of looper thread 				

To the next page

Troubles (1)	Troubles (2)	Cause (1)	Cause (2)	Corrective measures
From the previous page	5-5) Skipping in top cover stitch (right)	5-A) Spreader	A-1) Incorrect shape of pointed end of spreader disables scooping a thread.	Replace it with the genuine part.
		5-B) Needle	B-1) Needle bend, improper needle attaching and wrong needle	Replace the needle with the new one, Use UY128GAS.
		5-C) Spreader adjustment	C-1) Incorrect height, protruding amount, longitudinal position, stroke and timing	Refer to the standard adjustment figures.
		5-D) Spreader thread guide	D-1) Incorrect height, position	Refer to the standard adjustment figures.
		5-E) Needle height	E-1) Needle bar position is too low.	Refer to the standard adjustment figures.
		5-F) Threading	F-1) Incorrect threading	Refer to threading diagram.
		5-G) Needle clamp thread guide	G-1) Incorrect height, position, front and rear	Refer to the standard adjustment figures.
		5-H) Spreader thread tension	H-1) Spreader thread tension is too weak.	Increase tension.
		5-I) Spreader take-up thread drawing-in amount	I-1) Incorrect drawing-in amount of thread	Refer to the standard adjustment figures.

Skipping in top covering stitch by right needle

Right needle

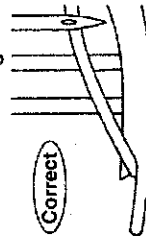

Right needle does not stride over the top covering thread.

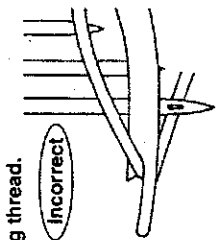

Left Middle Right

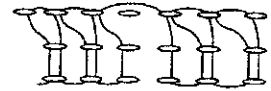
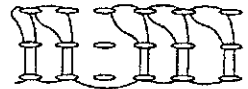

Skipping in top covering stitch by right needle
Simultaneous skip by left and middle needle

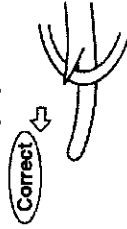

Spreader does not fetch the top covering thread.

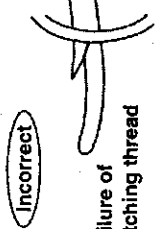

Failure of catching thread

Troubles (1)	Troubles (2)	Cause (1)	Cause (2)	Corrective measures
From the previous page	5-6) Skipping in top covering stitch (Middle)	6-A) Needle	A-1) Needle bend, improper needle attaching and wrong needle	Replace the needle with the new one, Use UY128GAS.
		6-B) Spreader adjustment	B-1) Incorrect height, protruding amount, longitudinal position, stroke and timing	Refer to the standard adjustment figures.
		6-C) Needle height	C-1) incorrect needle bar position	Refer to the standard adjustment figures.
		6-D) Threading	D-1) Incorrect threading	Refer to threading diagram.
		6-E) Spreader thread tension	E-1) Spreader thread tension is too weak	Increase tension.
		6-F) Spreader pull-off	F-1) Incorrect drawing-in amount of thread	Refer to the standard adjustment figures.
		6-G) Spreader thread guide	G-1) Incorrect height and position	Refer to the standard adjustment figures.

Skipping in top covering stitch by middle needle
Middle needle does not scoop top covering thread.

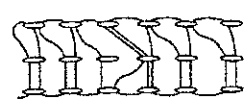

Left Middle Right

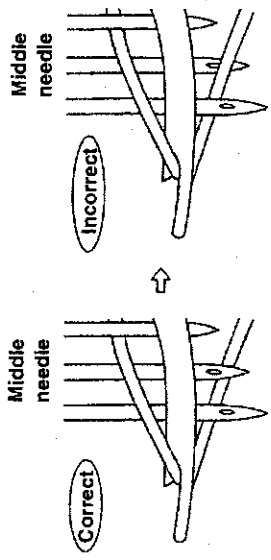

Middle needle strides over top covering thread sometimes.

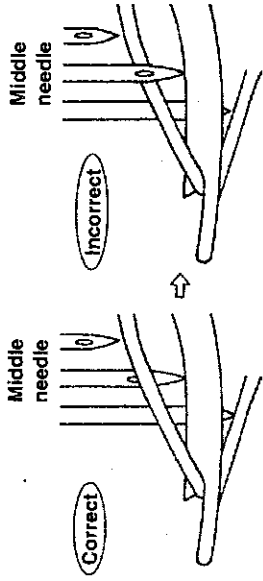

To the next page

Troubles (1)	Troubles (2)	Cause (1)	Cause (2)	Corrective measures
From the previous page	5-7) Skipping in top covering stitch (Left)	7-A) Spreader	A-1) Incorrect shape of pointed end disables scooping a thread.	Replace it with the genuine part.
		7-B) Needle	B-1) Needle bend, improper needle attaching and wrong needle	Replace needle with new one, Use UY128GAS.
		7-C) Spreader adjustment	C-1) Incorrect height, protruding amount, position, front and rear	Refer to the standard adjustment figures.
		7-D) Spreader thread guide	D-1) Incorrect height and position	Refer to the standard adjustment figures.
		7-E) Needle height	E-1) Needle bar position is too low.	Refer to the standard adjustment figures.
		7-F) Threading	F-1) Incorrect threading	Refer to threading diagram.
		7-G) Spreader thread tension	G-1) Spreader tension is too weak.	Increase tension.
		7-H) Spreader pull-off drawing-in amount of thread	H-1) incorrect drawing-in amount of thread	Refer to the standard adjustment figures.

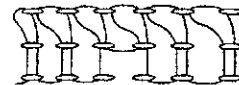

Skipping in top covering stitch by left needle
Left needle does not scoop top covering thread.

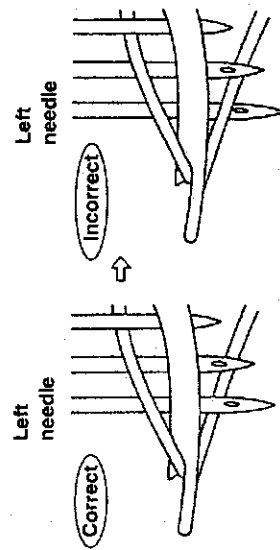

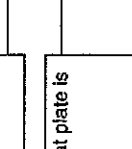
Troubles (1)	Troubles (2)	Cause (1)	Cause (2)	Corrective measures
From the previous page	5-8) Single chain thread cast-off (Right, Middle, Left)	8-A) Needle	A-1) Needle bend, improper needle attaching and wrong needle	Replace the needle with the new one, Use UY128GAS.
		8-B) Needle height	B-1) Needle bar position is too high.	Refer to the standard adjustment figures.
		8-C) Threading	C-1) Incorrect threading	Refer to threading diagram.
		8-D) Throat plate	D-1) R of stitch tongue in throat plate is too small. 	Increase R. Polish correctly.
		8-E) Looper	E-1) R of looper's ventral section is too large and ridgeline is not tense, for which needle thread is likely to slip from looper.	Replace it with the genuine part.
		8-F) Looper adjustment	F-1) Too little contact amount between looper's back and needle	Refer to the standard adjustment figures.
		8-G) Thread tension	G-1) Thread tension is too weak.	Increase tension.
		8-H) Needle thread guide rod	H-1) Low position of thread guard results in too large needle thread loop.	Lift thread guide position.
		8-I) Thread guard position	I-1) Thread guard position is too high.	Refer to the standard adjustment figures.
		8-J) Auxiliary thread tension adjustment	J-1) Use of nipper could easily generate this trouble.	Do not use nipper.
		8-K) Looper thread cam thread guide position	K-1) Drawing-in amount of looper thread is too much.	Reduce drawing-in amount of thread.

To the next page

One chain stitch by right needle

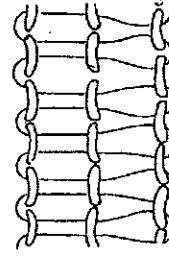
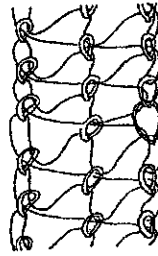
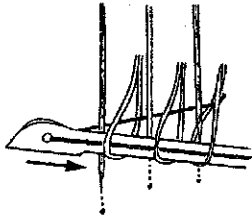

One chain stitch by middle needle

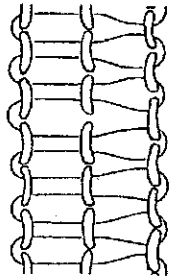
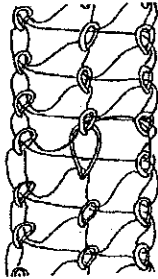
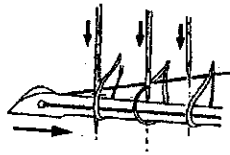

One chain stitch by left needle

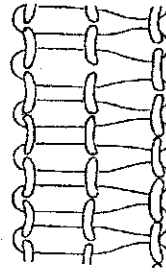
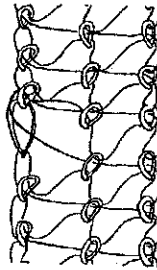
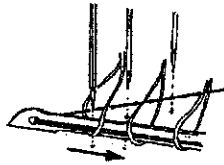



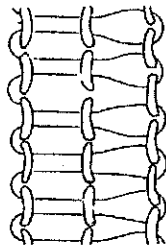
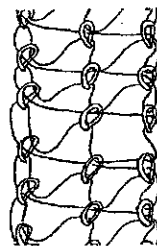
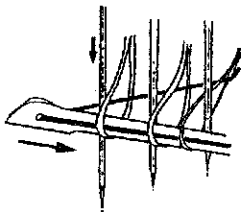

Right needle thread miss

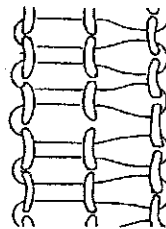
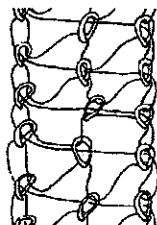
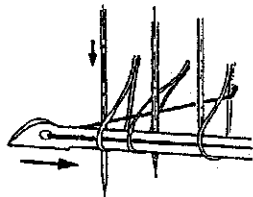

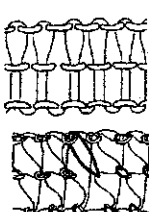
Middle needle thread miss

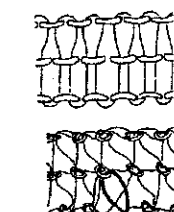

Troubles (1)	Troubles (2)	Cause (1)	Cause (2)	Corrective measures
From the previous page	5-9) Double bonding stitch (Middle, Left)	9-A) Throat plate	A-1) R of stitch tongue in throat plate is too large. Stitch tongue is too short.	Replace it with the genuine part.
	9-B) Needle	B-1) Worn out needle point, needle bend, wrong needle	Replace needle with new one, Use UY128GAS.	
Right needle enters middle needle loop. 	9-C) Looper	C-1) Flaw in looper's ventral section, incorrect polishing	Replace the looper when modified or its shape is changed too much.	
	9-D) Needle height	D-1) Needle bar position is too low.	Refer to the standard adjustment figures.	
Middle needle enters left needle loop. 	9-E) Threading	E-1) Incorrect threading	Refer to threading diagram.	
	9-F) Needle thread tension	F-1) Tension is too weak.	Increase tension.	
	9-G) Needle thread guide rod	G-1) Substandard lower positioning of thread guide	Adjust the thread guide position upward.	
	9-H) Auxiliary thread tension adjustment	H-1) Use of nipper is likely to generate this trouble.	Do not use nipper.	

To the next page

Troubles (1)	Troubles (2)	Cause (1)	Cause (2)	Corrective measures
From the previous page	5-10) Irregular stitches (Left, Middle, Right)	10-A) Throat plate	A-1) Incorrect polishing	Polish correctly.
		10-B) Spreader adjustment	B-1) Stroke of spreader is too large.	Refer to the standard adjustment figures.
		10-C) Looper	C-1) Worn out looper's pointed end and incorrect polishing	Replace the looper when modified or its shape is changed too much.
		10-D) Top covering thread take-up	D-1) Drawing-in amount of top covering thread is too much.	Refer to the standard adjustment figures.
		10-E) Needle thread tension	E-1) Needle thread tension is too weak.	Increase tension.
		10-F) Threading	F-1) Incorrect threading	Refer to threading diagram.
		10-G) Top covering thread tension	G-1) Thread tension is too weak.	Increase tension.
		10-H) Looper thread cam thread guide position	H-1) Drawing-in amount of looper thread is too much.	Reduce drawing-in amount of thread.
		11-A) Throat plate	A-1) Incorrect polishing. Too long stitch tongue	Correct or replace part.
		11-B) Needle	B-1) Worn out needle point, needle bend, wrong needle	Replace needle with new one. Use UY128GAS.
11-C) Looper	C-1) Worn out looper's pointed end, incorrect polishing	Replace the looper when modified or its shape is changed too much.		
11-D) Needle height	D-1) Needle bar position is too low.	Refer to the standard adjustment figures.		
11-E) Threading	E-1) Incorrect threading	Refer to threading diagram.		
11-F) Needle thread tension	F-1) Tension is too weak.	Increase tension.		
11-G) Needle thread guide rod	G-1) Either the position of thread guide is too low or too high.	Refer to the standard adjustment figures.		
11-H) Looper thread tension	H-1) Tension is too strong.	Reduce tension.		
11-I) Looper thread cam thread guide position	I-1) Drawing-in amount of looper thread is too little.	Increase drawing-in amount of thread.		
5-11) Ill-tensed seam				

To the next page

Troubles (1)	Troubles (2)	Cause (1)	Cause (2)	Corrective measures
From the previous page	5-12) Irregular stitches in top covering stitches	12-A) Spreader	A-1) Flaw in pointed end of spreader obstructs smooth thread threading. 	Replace when modified or its shape is changed too much.
		12-B) Spreader adjustment	B-1) Spreader stroke is too large.	Refer to the standard adjustment figures.
		12-C) Thread guide	C-1) Flaw, burr in slot	Replace when modified or its shape is changed too much.
		12-D) Top covering thread take-up	D-1) Drawing-in amount of top covering thread is too much or too little.	Refer to the standard adjustment figures.
		12-E) Needle thread tension	E-1) Needle thread tension is too weak.	Increase tension.
		12-F) Threading	F-1) Incorrect threading	Refer to threading diagram.
		12-G) Top covering thread tension	G-1) 1st thread tension is too weak.	Increase tension.
		12-H) Looper thread cam thread guide position	H-1) Drawing-in amount of looper thread is too much.	Reduce drawing-in amount of thread.
		12-I) Stitch tongue of presser foot	I-1) Thread threading is not smooth due to incorrect shape of stitch tongue.	Replace when modified or its shape is changed too much.
	5-13) Bulge	13-A) Throat plate	A-1) Stitch tongue is too short.	Use throat plate provided with long stitch tongue.
		13-B) Threading	B-1) Incorrect threading	Refer to threading diagram.
		13-C) Needle thread tension	C-1) Tension is too strong.	Reduce tension.
		13-D) Looper thread tension	D-1) Tension is too strong.	Reduce tension.
		13-E) Looper thread cam thread guide position	E-1) Drawing-in amount of upper thread is too little.	Increase drawing-in amount.

To the next page

Troubles (1)	Troubles (2)	Cause (1)	Cause (2)	Corrective measures
From the previous page	5-14) Defective chain-off thread (with top covering stitch)	14-A) Throat plate	A-1) Thread threading is not smooth due to incorrect polishing in stitch tongue.	Replace when polished or its shape is changed too much.
		14-B) Spreader adjustment	B-1) Stitch skip in top covering stitch due to incorrect adjustment	Refer to the standard adjustment figures.
		14-C) Looper adjustment	C-1) Stitch skip due to incorrect adjustment	Refer to the standard adjustment figures.
		14-D) Top covering thread take-up	D-1) Drawing-in amount of top covering thread is too much or too little.	Refer to the standard adjustment figures.
		14-E) Needle thread tension	E-1) Needle thread tension is too weak.	Increase tension.
		14-F) Threading	F-1) Incorrect threading	Refer to threading diagram.
		14-G) Top covering thread tension	G-1) 1st thread tension is too weak.	Increase tension.
		14-H) Stitch tongue of presser foot	H-1) Thread threading is not smooth due to incorrect shape of stitch tongue.	Replace when its shape is modified or changed too much.
		14-I) Needle	I-1) Worn out needle point, needle bend, wrong needle	Replace needle with new one, Use UY128GAS.
		14-J) Feed dog	J-1) Flaw on surface in feed dog	Modify or replace

JUKI®

JUKI CORPORATION

INTERNATIONAL SALES H.Q.
8-2-1, KOKURYO-CHO, CHOFU-SHI
TOKYO 182-8655, JAPAN
PHONE : (81)3-3430-4001 to 4005
FAX : (81)3-3430-4909 . 4914 . 4984
TELEX : J22967

Copyright © 1998-2002 JUKI CORP.
本書の内容を無断で転載、複写することを禁止します。
All rights reserved throughout the world.

JUKI 株式会社

〒182-8655 東京都調布市国領町8-2-1
TEL. 03-3480-1111(代表)

営業本部
TEL. 03-3430-4001(ダイヤルイン)

お問い合わせ、ご相談は
To order or for further
information,
please contact:

※このパーツリストは商品改良のため予告なく変更する事があります。
* The description covered in this parts list is subject to change for improvement of the commodity without notice.
※このパーツリストは、2002年7月 現在の商品仕様で編集したものです。
* This parts list is edited in accordance with the product specifications as of July 2002.