

JUKI®

DLU-490-4 SERIES

**1-Needle, Bottom & Variable Top Feed Lockstitch
Machine with Automatic Thread Trimmer**

ENGINEER'S MANUAL

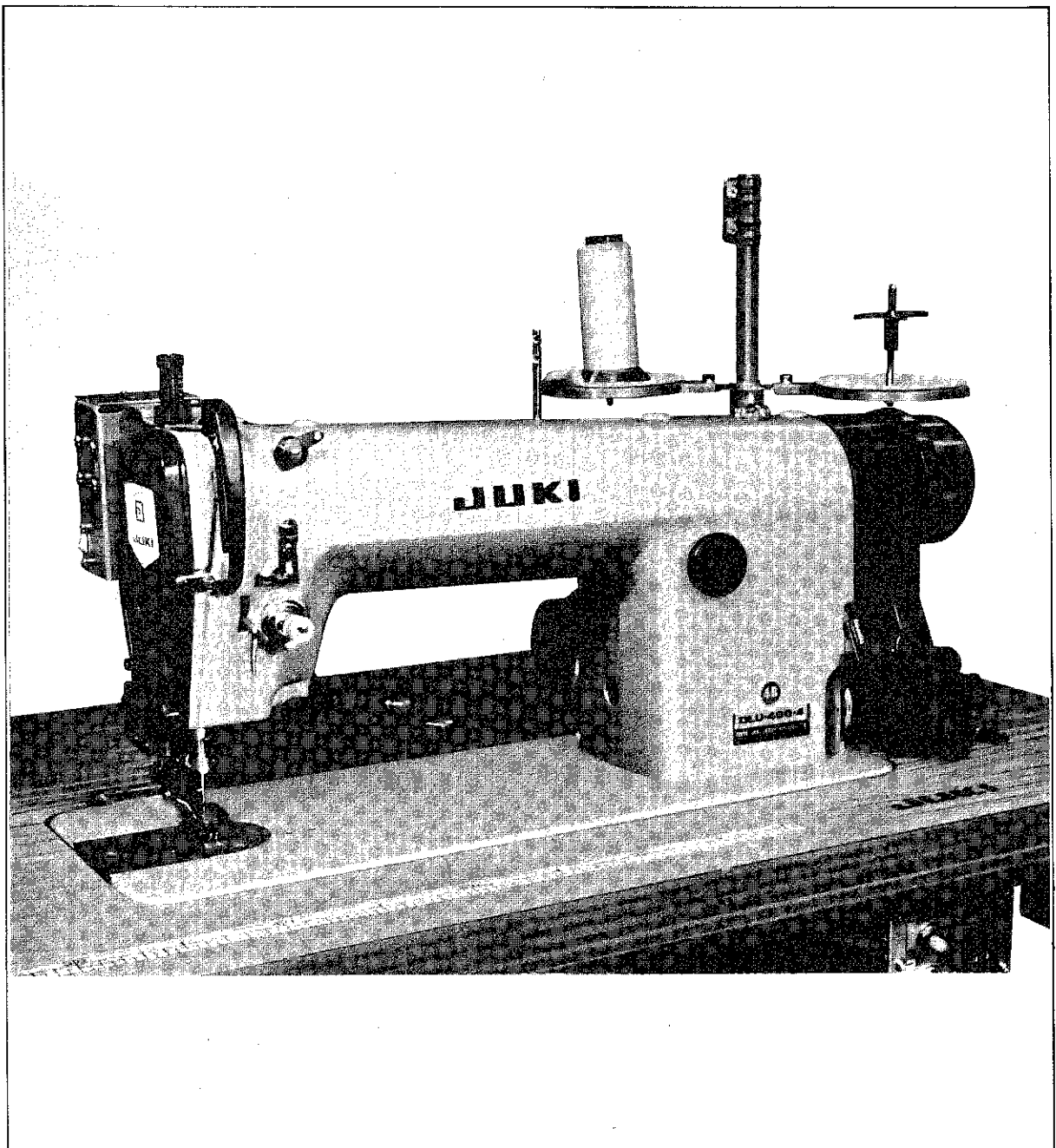

TOKYO JUKI INDUSTRIAL CO., LTD.

INTRODUCTION

This ENGINEER'S MANUAL FOR MODEL DLU-490 mainly consists of three sections.

In the first section, "Standard Adjustment" provides the engineers with the basic figures and standards which have to be complied with in adjusting each machine. In the second section, how to disassemble and re-assemble the main components and how to adjust after assembling are described in detail.

In the third section, "Troubles and Corrective Measures" helps the engineers with troubling shooting.

We believe that the contents will be great help to each engineer for the correct maintenance of JUKI DLU-490.

CONTENTS

1. STANDARD ADJUSTMENTS	1
(1) Needle bar height	1
(2) Needle-to-hook relation	1
(3) Projection of the feed dog teeth	1
(4) Feed dog-to-needle relation	1
(5) Slant of the feed dog	3
(6) Pressure of the presser foot and the walking foot	3
(7) Relation between the top-feed indicating plate (scale) and the pointer	5
(8) Actual top-feed amount when the top feed adjusting dial is set to the maximum figure	5
(9) Vertical phase of the top-feed action	5
(10) Horizontal phase of the top-feed action	7
(11) Longitudinal position of the top feed dog	7
(12) Balance of forward and reverse feed pitches	9
(13) Position of the reverse feed solenoid	9
(14) Position of the wiper solenoid	9
(15) Position of the wiper	11
(16) Stopper of PF-1 pedal/knee presser-controlled gathering mechanism	11
2. HOW TO DISASSEMBLE AND REASSEMBLE THE MACHINE	13
(1) Top feed mechanism in the face plate	13
o How to disassemble	13
o Attaching the presser bar	14
o Connecting the presser bar to the walking foot arm bracket assembly	14
o Attaching the walking foot driving link	14
o Connecting the walking foot arm bracket (asm) to the walking foot driving link and the walking foot driving arm	15
(2) Adjustment of the top feed mechanism in the face plate	16
o Positioning the walking foot on the throat plate	16
o Smooth and straight motion of the presser foot	17
(3) Disassembling and assembling the top feed driving mechanism	19
o Disassembling the reverse feed shaft	19
o Disassembling the walking foot rock shaft	19
o Assembling the reverse feed shaft	19
o Fixing the spring to the spring suspension bracket	21
3. HOW TO REMOVE EXCESSIVE PLAY AND JARRING	23
(1) Walking foot rock shaft	23
(2) Walking foot adjusting base	23
(3) Reverse feed shaft	24
4. ADJUSTMENT OF THE TOP FEED DRIVING MECHANISM	25
(1) Position of cam	25
(2) Position of the connecting arm	26
(3) Longitudinal positioning of the walking foot	27
(4) Vertical phase of the top feed action	27
5. HOW TO INSTALL AND ADJUST OTHER COMPONENTS	29
(1) Reverse feed mechanism	29
(2) Wiper components	30
(3) Pedal/knee presser-controlled gathering mechanism, PF-1	31
6. TROUBLES AND CORRECTIVE MEASURES	34
7. USE OF DIFFERENT GAUGE SETS	46

STANDARD ADJUSTMENTS

(1) Needle bar height

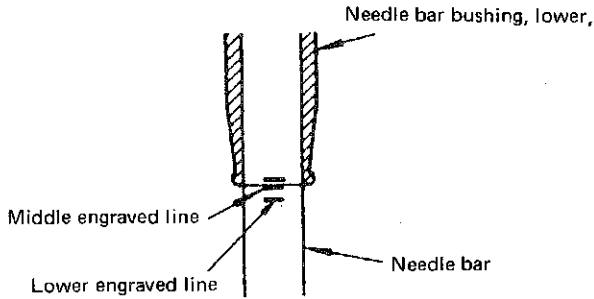

The middle engraved line on the needle bar must meet the bottom end of the needle bar bushing (lower) when the needle bar has come down to the lowest point of its stroke.

(2) Needle-to-hook relation

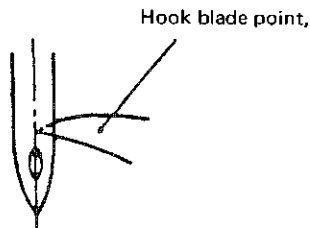

The pointed end of the hook must be in line with the needle center line with a clearance of 0.02 to 0.05 mm when the needle bar has gone up and its lower engraved line has met the bottom end of the needle bar bushing (lower).

(3) Projection of the feed dog teeth

The front tooth of the feed dog must jut out 0.7 mm from the throat plate surface when the feed dog is at the highest point.

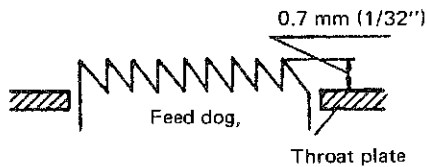

(4) Feed dog-to-needle relation

The front tooth of the feed dog must level with the throat plate surface when the needle has come down and the top end of the needle eye has leveled with the throat plate surface.

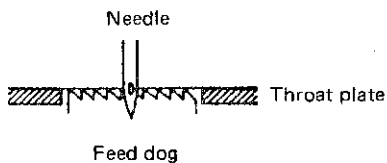

HOW TO ADJUST	EFFECT OF ADJUSTMENT
<ul style="list-style-type: none"> ○ Release the needle bar from the needle bar connection by loosening a fastening screw and adjust the height of the needle bar. 	<ul style="list-style-type: none"> ○ It is advisable not to change the needle bar frequently, because it influences the needle-to-feed dog and the needle-to-hook relations.
<ul style="list-style-type: none"> ○ Loosen three setscrews and adjust the hook. 	<ul style="list-style-type: none"> ○ If you provide a greater clearance than the standard, it may cause stitch skipping or thread breaking. If the hook blade acts on the needle at an earlier timing, it may produce a tighter stitch but, on the other hand, is liable to cause stitch skipping. If the hook blade acts on the needle at a later timing, it may cause “balloon” stitching or skipping.
<ul style="list-style-type: none"> ○ Release the feed driving shaft crank (rear) and adjust the height of the feed dog. 	<ul style="list-style-type: none"> ○ If the feed dog is too high, it may permit the fabric to bend or break the needle. If it is too low, it may feed the fabric irregularly causing uneven stitches.
<ul style="list-style-type: none"> ○ Release the feed eccentric cam by loosening two setscrews and adjust the feed dog motion. 	<ul style="list-style-type: none"> ○ If the feed dog sinks earlier than the standard, it prevents such troubles as “balloon” stitching, rise stitching, carry-away of needle, etc. but produces loose stitches.

STANDARD ADJUSTMENTS

(5) Slant of the feed dog

The marker spot engraved on the feed bar shaft must be in line with its two setscrews.
(In this state, the feed dog stays in the horizontal position.)

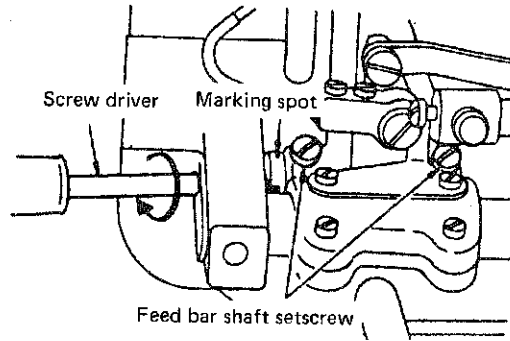
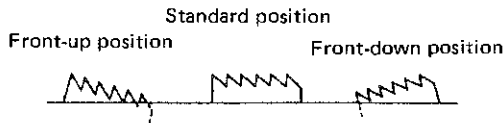

(6) Pressure of the presser foot and the walking foot

Gauge set types	Height of presser spring regulator (A)	Height of guide bar (B)
BA. BB. BC	33 m/m	16.5 m/m
D	33	17
E	33	16.5
J	33	16.5
L	33	16.5
M	33	16.5
N	33	16.5
P	33	16.5
S	35	16

(ADJUSTMENT STANDARDS)

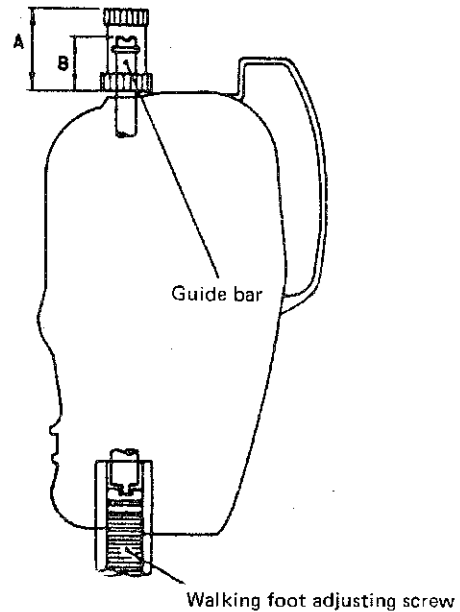

(Notes) The figures shown by the above table indicate the reference height of the presser spring regulator and the guide bar measuring from the arm surface.
Increase or decrease the height depending on the characteristics of the fabric to stitch.

HOW TO ADJUST	EFFECT OF ADJUSTMENT
<ul style="list-style-type: none"> ○ Loosen two setscrews and adjust the feed bar shaft by rotating clockwise for "front-up" or counterclockwise for "front-down" position. 	<ul style="list-style-type: none"> ○ The feed dog in "front-up" position prevents puckering and "front-up" position prevents puckering and "front-down" position minimizes breaking of the fabric yarn of knit materials.
<ul style="list-style-type: none"> ○ Distance "A" : Turn the presser spring regulator clockwise to reduce (pressure increased) or counterclockwise to increase distance "A" (pressure reduced). Distance "B" : With the presser foot "down" (the bottom face of the presser foot rests on the throat plate), push down the guide bar using a screw driver and turn the nut; turn clockwise to increase or counterclockwise to reduce the pressure of the walking foot. 	<ul style="list-style-type: none"> ○ The gathering stitch capability depends largely on the pressure difference between the presser foot and the walking foot. It is increases as the pressure difference is increased. But, if the pressure of the presser foot is too low, it fails to feed the material regularly resulting stitch jamming. If the pressure of the walking foot is too high, it may leave tooth marks on the fabric.

STANDARD ADJUSTMENTS

(7) Relation between the top-feed indicating plate (scale) and the pointer

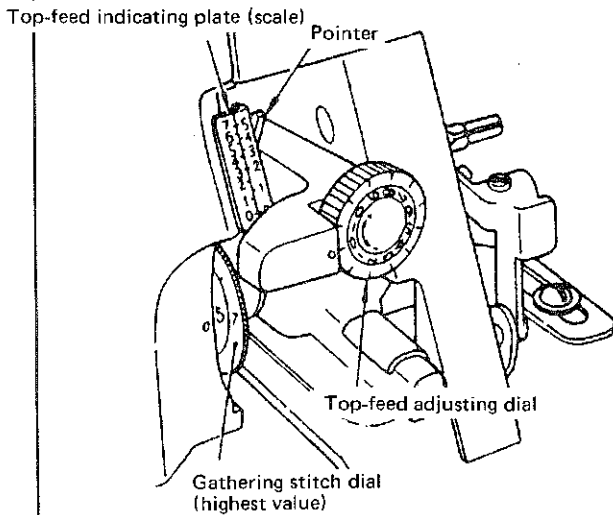

Set the gathering stitch dial to the largest figure and turn clockwise the top-feed adjusting dial for the highest value, and the pointer must indicate "7-5" scale.

(8) Actual top-feed amount when the top feed adjusting dial is set to the maximum figure.

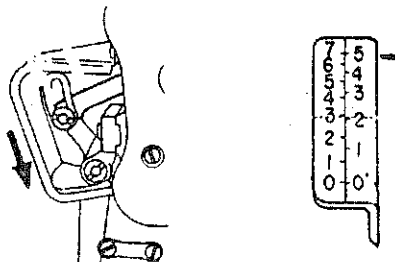

6.5 mm (1/4")
(When the driving link shaft is fixed at the lowest point of its oval hole and the pointer indicates "7-5" scale on the top feed indicating plate).

(9) Vertical phase of the top-feed action

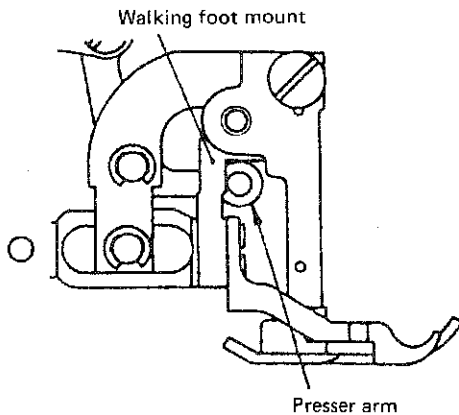

When the stitch dial is set for "3" and when the bottom face of the presser foot touches the throat plate, the top end of the presser arm must come into contact with the bottom end of the walking foot mount.

HOW TO ADJUST	EFFECT OF ADJUSTMENT
<ul style="list-style-type: none"> ○ In the state of "7-5", loosen two setscrews which fix the top-feed indicating plate (scale) on the back of the machine arm and adjust the position of the indicating plate . 	<ul style="list-style-type: none"> ○ If the pointer does not accurately indicate the amount of top feed, it will confuse the operator.
<ul style="list-style-type: none"> ○ Pull out a rubber plug located below the side cover and adjust the position of the adjusting arm which is located on the reverse feed control lever. (See also 4. Adjustment of Top Feed Driving Mechanism) 	<ul style="list-style-type: none"> ○ If it exceeds 6.5 mm, the top feed components may hit neighboring parts. If it is smaller than 6.5 mm, the gathering stitch capability is reduced.
<ul style="list-style-type: none"> ○ Loosen the screw which fastens the walking foot driving arm when the presser foot touches the throat plate, and push the presser arm in (A) direction until it touches the walking foot mount and tighten the fastening screw. <div data-bbox="210 1803 782 2011"> <p data-bbox="542 1966 782 2011">Walking foot driving arm fastening screw</p> </div>	<ul style="list-style-type: none"> ○ If the walking foot rises before the presser foot touches the throat plate, it reduces the amount of gathering. If the walking foot rises after the presser foot touches the throat plate, it pushes the top fabric backwards momentarily causing also the reduction of the gathering amount. In the former case, the presser bar may twist and reduce the efficiency of feed.

STANDARD ADJUSTMENTS

In this moment, make sure that the walking foot does not rise higher than the levels as listed below for each type;

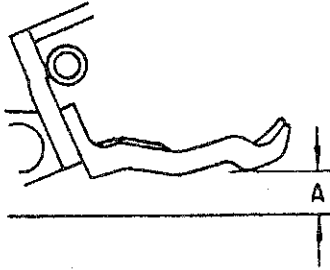

BA – BC E	type type	Approx. 3 mm (1/8")
D	type	Approx. 1.6 mm (1/16")
J M P	type	Approx. 2.7 mm (7/64")
S	type	Approx. 2.4 mm (3/32")

(10) Horizontal phase of the top-feed action

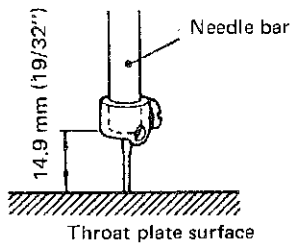

Turn the handwheel to bring the needle bar at its highest point and then turn it further in the normal direction until the distance between the bottom end of the needle bar and the top face of the throat plate becomes 14.9 mm. In this state, the screw No. 2 in the cam must be in line with the axis of the main shaft. When the throat plate of 2.6 mm thick is installed, the above-mentioned distance is 14.3 mm instead of 14.9 mm.

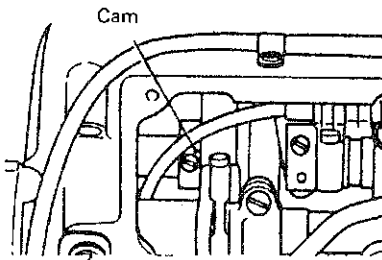

(11) Longitudinal position of the top feed dog

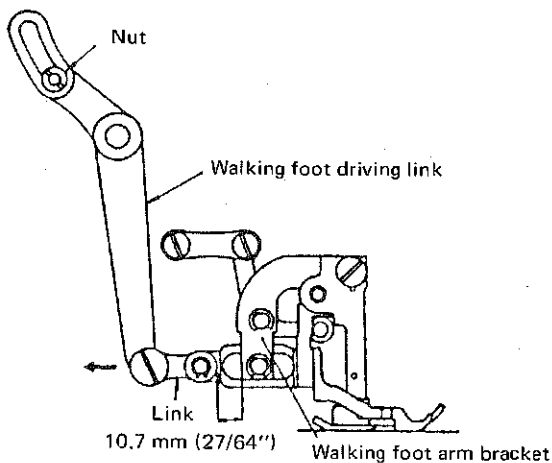

The clearance between the link and the walking foot arm bracket must be 10.7 mm when the walking foot driving link has moved back extremely with the maximum setting of the top feed amount.

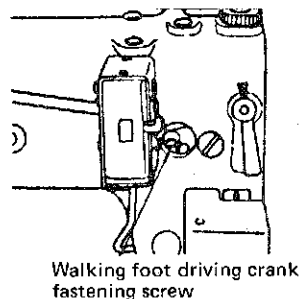

HOW TO ADJUST	EFFECT OF ADJUSTMENT
<ul style="list-style-type: none"> ○ Remove the side plate from the machine head and loosen two setscrews in the cam which are located on the back of the main shaft. Fix the main shaft in a position where the distance between the bottom end of the needle bar and the top face of the throat plate (2 mm thick) is 14.9 mm and align the setscrew No. 1 with the axis of the main shaft and tighten both the No. 1 and No. 2 setscrews firmly. 	<ul style="list-style-type: none"> ○ If the No. 1 setscrew is fixed above the axis of the main shaft, it forces the fabric to momentarily withdraw. If it is fixed below the axis of the main shaft, the fabric may be damaged.
<ul style="list-style-type: none"> ○ Set the top-feed adjusting dial for the maximum amount (fix the nut in the lowest position of the oval hole in the walking foot driving link). Turn handwheel until the walking foot driving link has gone back entirely in the direction of the arrow and loosen the screw which fastens the walking foot driving crank. Then, the walking foot driving link will move freely in the longitudinal direction. Provide a 10.7 mm clearance between the link and the walking foot arm bracket and fasten the screw in the walking foot driving crank taking care not to change the provided clearance. 	<ul style="list-style-type: none"> ○ If the clearance is too much greater or smaller than 10.7 mm, some of the top feed components may hit the neighbouring parts causing a noise during operation. <p>AFTER THIS ADJUSTMENT go to page 26 ADJUSTMENT # 3</p>

STANDARD ADJUSTMENTS

(12) Balance of forward and reverse feed pitches

The feed pitch in the reverse sewing must be 90 to 100% of the forward sewing.

(13) Position of the reverse feed solenoid

Set the machine for a stitch length of 3 mm to 3.5 mm (1/8" to 9/64") and depress the reverse feed control lever permitting the plunger of the solenoid to move in the direction of arrow A. In this state, the plunger rubber ring must touch the end face of the solenoid.

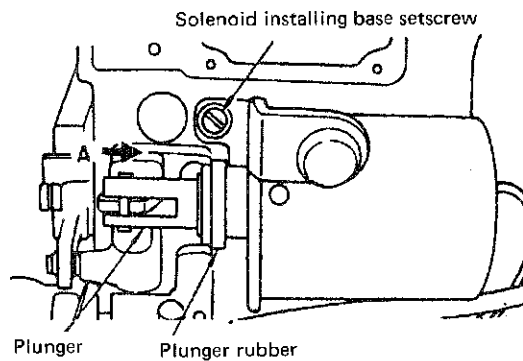

(14) Position of the wiper solenoid

Clearance between the wiper driving plate and the wiper driving arm must be about 0.5 mm (1/64").

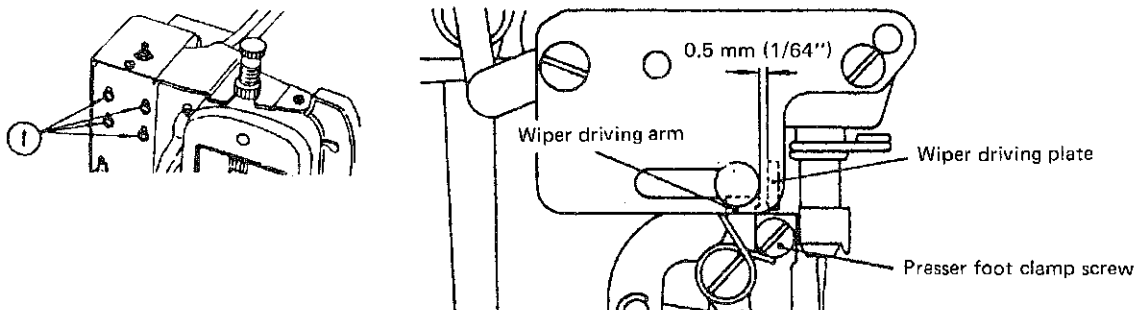

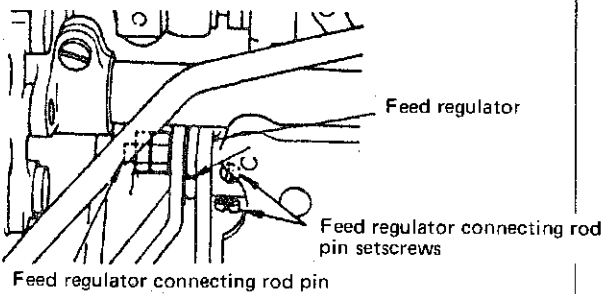
HOW TO ADJUST	EFFECT OF ADJUSTMENT
<ul style="list-style-type: none"> ○ Release the feed regulator connecting rod pin by loosening its setscrews and turn the pin using a hex socket wrench until the reverse feed pitch becomes approximately identical to the forward feed pitch. 	<ul style="list-style-type: none"> ○ If the reverse feed pitch differs too much from the forward feed pitch, wrong reverse stitches may be formed. Bring the marker line engraved on the pin upwards when you want to increase the forward-to-reverse feed pitch ratio, and vice versa.
<ul style="list-style-type: none"> ○ Loosen slightly the screw which fastens the solenoid installation base in place and adjust the position of the solenoid by lightly tapping. After the solenoid has been correctly positioned, tighten the screw firmly. 	<ul style="list-style-type: none"> ○ If the solenoid is set too far to the left, the length of the reverse stitch will become less than 3 mm (1/8"). If it is set too far to the right, the attracting power of the solenoid is reduced causing irregular reverse stitches.
<ul style="list-style-type: none"> ○ Loosen four screws which fix the wiper solenoid to its installation base and adjust the position to provide a 0.5 mm clearance between the wiper driving arm and the wiper driving plate. 	<ul style="list-style-type: none"> ○ If the wiper solenoid is installed too high, it reduces the clearance causing the needle to hit the wiper. If it is too low, the stroke of the wiper becomes smaller causing the wiper to fail to catch the thread.

STANDARD ADJUSTMENTS

(15) Position of the wiper

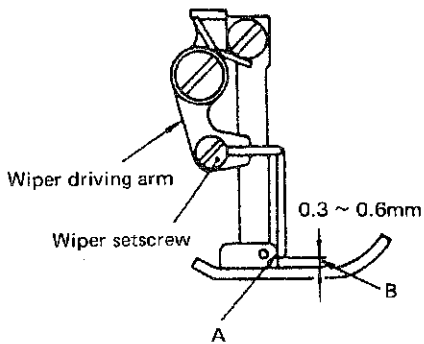

- (1) Center line "C" of the hooked end of the wiper must be in line with the center of the needle hole in the presser foot.

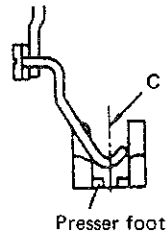

- (2) When the wiper driving arm is pressed against the head of the presser foot setscrew, the wiper must touch the front end of the presser foot at point "A" and provide a 0.3 to 0.6 mm clearance at point "B".

(16) Stopper of FP-1 pedal/knee presser-controlled gathering mechanism

Set the stitch dial for "3" and the top-feed adjusting plate "3", and depress the reverse feed control lever. In this state, the wire roller must touch the adjusting plate.

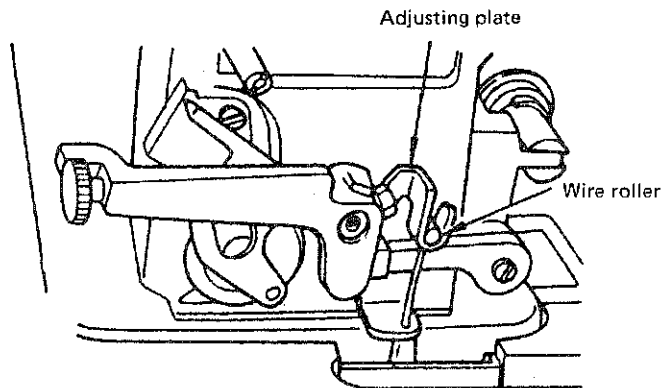

HOW TO ADJUST	EFFECT OF ADJUSTMENT
<ul style="list-style-type: none"> ○ Adjust the position of the wiper after loosening its setscrew. If you can't obtain the specified position, do it by bending the wiper itself. 	<ul style="list-style-type: none"> ○ If the wiper is wrongly positioned, it may hit other components such as the walking foot or the needle bar.
<ul style="list-style-type: none"> ○ Adjust it by means of the stopper screw of the gathering mechanism located under the machine table. Firmly tighten the lock nut after the adjustment. <div data-bbox="247 1198 774 1467" data-label="Diagram"> </div> <div data-bbox="399 1556 686 1691" data-label="Diagram"> </div> <ul style="list-style-type: none"> * If the machine is always used at a stitch length of 3 mm or less, set the stitch dial for 3 mm or less and depress the reverse feed control lever, and then adjust as mentioned above. By so doing, an excessive play in the knee (or pedal) operation is reduced. 	<ul style="list-style-type: none"> ○ If there is a clearance between the wire roller and the adjusting plate, it provides an excessive play in the pedal or the knee presser of the gathering mechanism causing the gathering mechanism to delay in response. If the wire roller always gives tension to the adjusting plate, it causes the top feed dog to reduce its amount of feed at the time of reverse stitch and damages the surface of the fabric.

2. HOW TO DISASSEMBLE AND REASSEMBLE THE MACHINE

(1) Top feed mechanism in the face plate

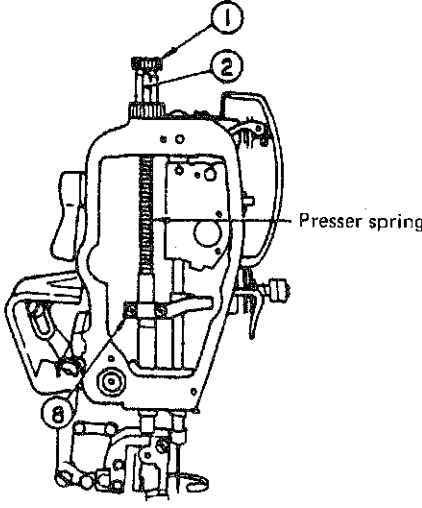
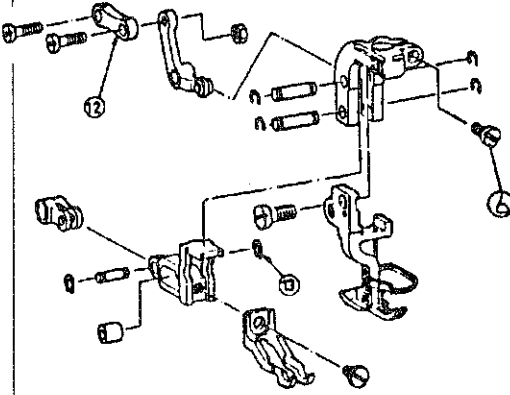
HOW TO DISASSEMBLE	ILLUSTRATION	REMARKS
<ol style="list-style-type: none"> 1. Remove presser spring regulator ① . 2. Push in guide bar ② and turn nut ③ counter-clockwise to reduce the tension of the guide bar spring. Then, remove the guide bar, guide bar spring and washer together. 3. Remove nuts from hinge screws ④ and ⑤ respectively and pull out these two hinge screws. 4. Loosen screw ⑥ which fastens the walking foot arm bracket. 5. Remove the face plate from the machine, hold the presser bar guide bracket and take out the walking foot arm bracket as an assembly. 6. Release presser bar guide bracket ⑧ from the presser bar and the presser bar can be removed. 		<p>You can smoothly pull out the presser bar by gently twisting walking foot arm bracket ⑦ .</p> <p>*While you disassemble this unit take care not to lose the parts especially ball ⑨ , spring supporter ⑩ and spring ⑪ which slip off easily.</p>
<p>The walking foot arm bracket assembly can be disassembled as illustrated on the right.</p>		<p>When you assemble the walking foot arm bracket, make sure that the oil holes in walking foot link ⑫ face upwards. When you set snap rings ⑬ on to the pins of the walking foot arm bracket, take care not to open or distort them too much in order to prevent them from dislocating during operation.</p>

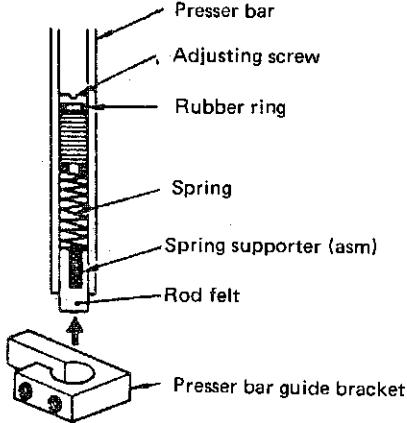
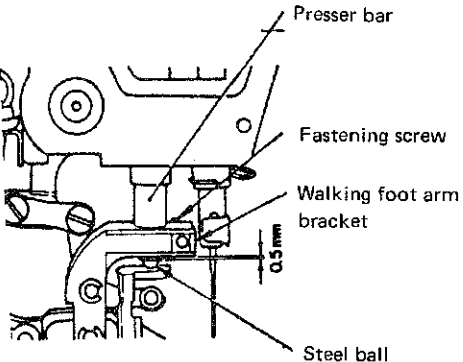
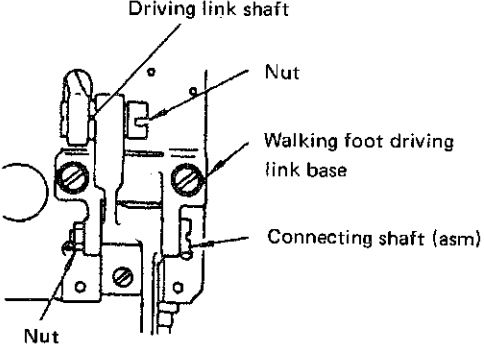
HOW TO ASSEMBLE	ILLUSTRATION	REMARKS
<p>○ Attaching the presser bar</p> <p>Assemble the presser bar as illustrated on the right, pass it through the presser bar guide bracket and connect to the presser bar bushing (lower). (The spring supporter contains a rod felt impregnated with grease.)</p>	 <p>Presser bar Adjusting screw Rubber ring Spring Spring supporter (asm) Rod felt Presser bar guide bracket</p>	
<p>○ Connecting the presser bar to the walking foot arm bracket assembly.</p> <p>Put a ball on top of the walking foot arm bracket assembly and put the presser bar assembly into the walking foot arm bracket. Insert the presser bar until its bottom end juts out about 0.5 mm (1/64") from the bottom face of the walking foot arm bracket and tighten its fastening screw.</p>	 <p>Presser bar Fastening screw Walking foot arm bracket 0.5 mm Steel ball</p>	<p>In order to permit the spring to act on the walking foot by means of the nut, take care not to fasten too much the screw which fixes the walking foot arm bracket.</p>
<p>○ Attaching the walking foot driving link</p> <p>Set the walking foot driving link base temporarily to the machine arm and connect the walking foot driving link to it by means of the connecting shaft (asm) and a nut. (This must be done after temporarily fixing the driving link shaft with a nut to the oval hole in the walking foot driving link)</p>	 <p>Driving link shaft Nut Walking foot driving link base Connecting shaft (asm) Nut</p>	<p>Don't tighten too much the nut of the driving link shaft, or it may hinder the smooth action of the walking foot driving link. After fixing this unit, loosen the screw which fastens the walking foot driving crank and ensure that the walking foot driving link moves smoothly without resistance.</p>

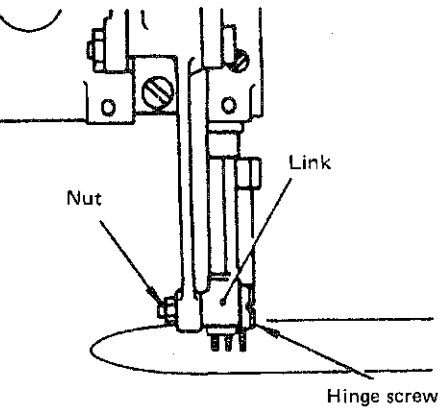
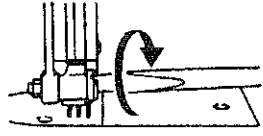
HOW TO ASSEMBLE	ILLUSTRATION	REMARKS
<p>○ Connecting the walking foot arm bracket (asm) to the walking foot driving link and the walking foot driving arm.</p> <ol style="list-style-type: none"> 1) Connect the link to the walking foot driving link by means of a hinge screw and a nut. 2) Connect the walking foot driving arm to the walking foot link by means of a hinge screw and a nut. 		<p>When tightening these nuts on the hinge screws, do it in the following way:</p> <ol style="list-style-type: none"> 1) Tighten the hinge screw fully and then loosen it slightly. 2) Hold the hinge screw not to turn by applying a screw driver blade to the slot on the screw head and tighten the nut. 

(2) Adjustment of the top feed mechanism in the face plate

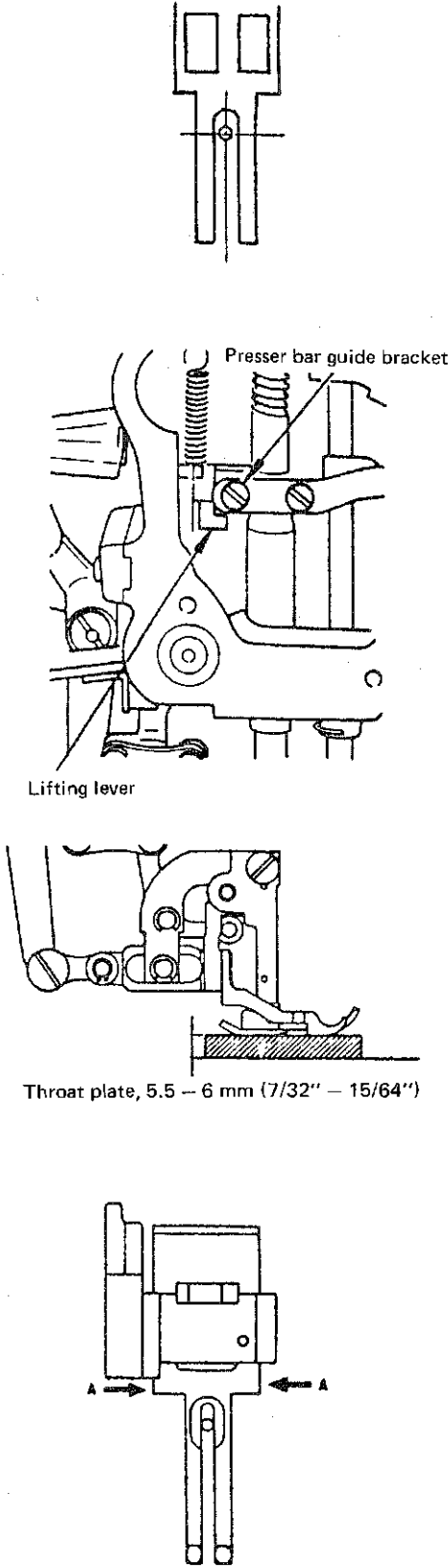
ADJUSTMENT	ILLUSTRATION	REMARKS
<p>* The top feed mechanism must be adjusted after it has been assembled in the preceding paragraph.</p> <p>○ Positioning the walking foot on the throat plate.</p> <p>Tighten temporarily two screws of the presser bar guide bracket in the way that the needle slot in the walking foot aligns with that in the throat plate. Next, turn the hand lifter fully to raise the presser foot and insert a 5.5 ~ 6.0 mm (7/32" ~ 15/64") thick gauge plate between the presser foot and the throat plate (throat plate = 2.0 mm thick, standard).</p> <p>Tighten the presser bar guide bracket setscrews firmly as you pushing both the presser bar and its guide bracket downwards. By so doing, you can permit the presser foot to rise 5.5 to 6.0 mm from the throat plate surface by means of the hand lifter.</p> <p>In the needle entry much deflects after the above-mentioned process, loosen slightly the fastening screw 6 of the walking foot arm bracket and adjust the needle entry by gently tapping the presser foot on face "A".</p>		<p>If the machine has a 2.6 mm thick throat plate, use a 5 to 5.5 mm (13/64" to 7/32") thick gauge plate instead of 5.5 to 6 mm thick one for the height adjustment.</p> <p>Make sure that there is a clearance between the presser bar guide bracket and the lifting lever when the hand lifter is turned. If there is no clearance, the presser foot fails to flatly rest on the throat plate causing insufficient feed.</p>

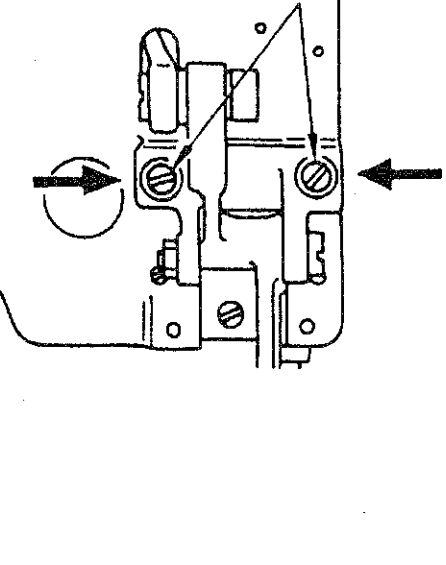
HOW TO ASSEMBLE	ILLUSTRATION	REMARKS
<p>○ Smooth and straight motion of the presser foot</p> <p>Lift the presser foot using your fingers and release it to let it down, and make sure that the presser foot comes down straight and smoothly. If not, fasten the walking foot driving link base by temporarily tightening its two screws, and adjust it laterally by gently tapping on its both ends alternately until the presser bar moves smoothly.</p>	<p style="text-align: center;">Walking foot driving link base setscrews</p>  <p style="text-align: center;">Walking foot driving crank fastening screw</p>	<p>Make this adjustment after loosening the fastening screw of the walking foot driving crank.</p> <p>Also loosen adjusting screw ③ so that the spring does not act on the top feed dog.</p>

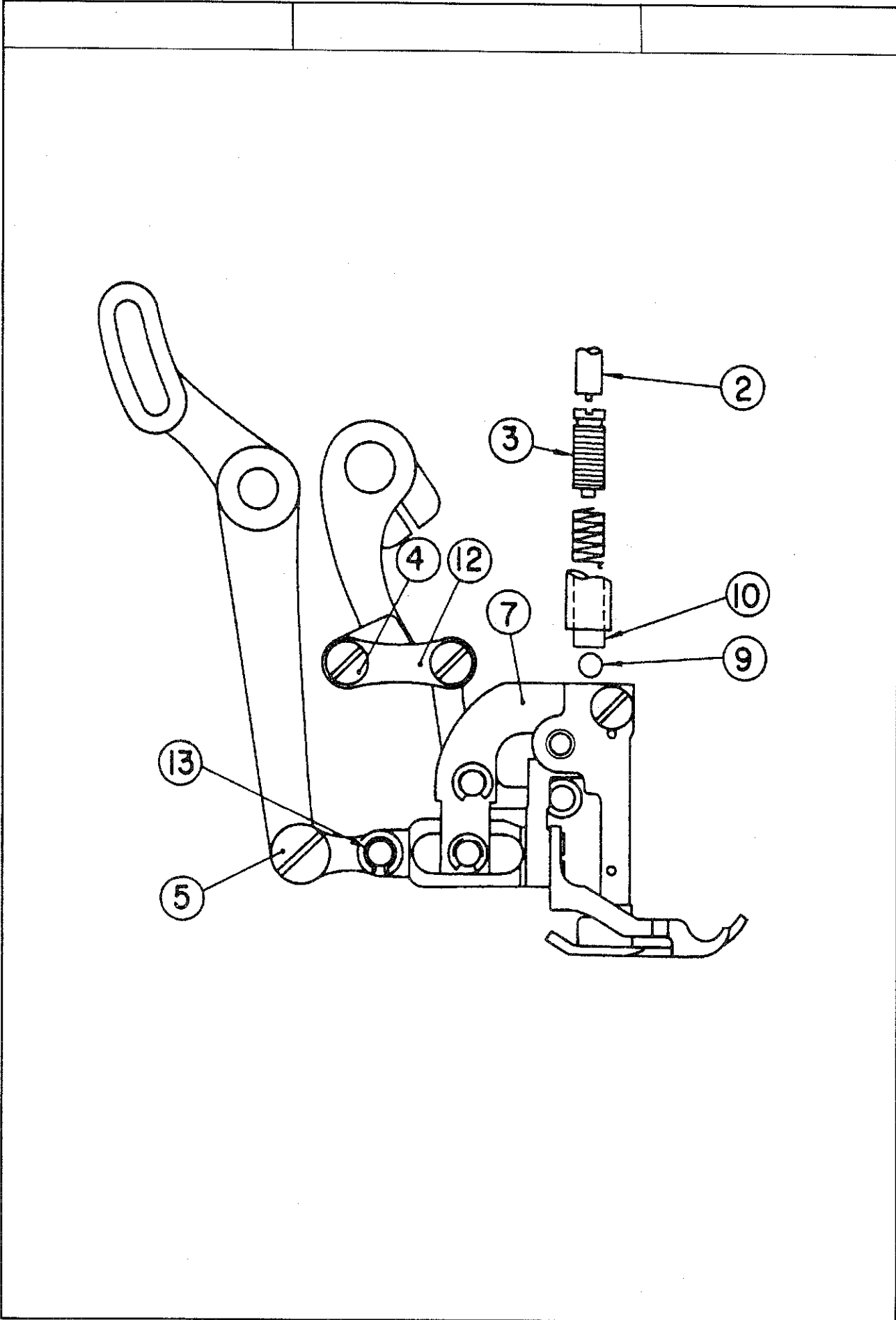

(3) Disassembling and assembling the top feed driving mechanism

HOW TO DISASSEMBLE	ILLUSTRATION	REMARKS
<p>○ Disassembling the reverse feed shaft Loosen screws which set and fasten connecting arm ②② , spring suspension bracket ②⑤ and crank ③① , respectively. Loosen screw ③③ located at the end of the reverse feed shaft and pull out the reverse feed shaft accompanied by adjusting plate assembly ②⑧ .</p>		<p>Prior to this disassembling work, detach the reverse feed lever tension spring from its anchor on the machine bed, and you will be able to disassemble the reverse feed shaft more easily.</p>
<p>○ Disassembling the walking foot rock shaft Loosen the setscrew and pull out pin ①⑦ from the walking foot driving rod. Loosen screw ①⑨ which fastens the walking foot driving crank and also a screw which fastens the walking foot driving crank arm and the walking foot rock shaft will rotate freely. Remove a rubber plug from the rear face of the machine arm and pull out the walking foot rock shaft. After this process, you can take out link arm ①⑥ , walking foot driving crank arm ①⑨ , hinge pin, etc. as an assembly. When necessary, you can remove feed driving rocker ②① after removing its setscrews which are accessible through a rubber-plugged opening in the rear face of the machine arm.</p>		<p>Pull out thrust collar ①④ from the shaft when the shaft has been removed from the machine.</p>

* (CAUTION) Since the rock shaft bushing (rear) has been accurately positioned on the walking foot rock shaft in our factory don't change its place under any circumstances.

HOW TO ASSEMBLE	ILLUSTRATION	REMARKS
<p>○ Assembling the reverse feed shaft As shown in Fig. II, attach adjusting plate (asm) ⑳, thrust bearing and thrust washer (small) to the reverse feed shaft on which the O-rings have been set and insert the assembly into the machine. In the machine, insert connecting arm ㉑, spring suspension bracket ㉒ and crank ㉓, in this order, and attach screw ㉔. Fasten each part to the reverse feed shaft in the way that there is no play in the axial direction (See 3. How to remove excessive play and jarring). After fixing the components, tighten the setscrews of the crank in the position where they rest on the flat face of the reverse feed shaft.</p>		<p>Set the stitch dial for "5", and you will be able to easily tighten the setscrew. If crank ㉓ defects to either direction, it will cause a backlash in the reverse feed shaft. Therefore, carefully tighten the setscrew by push up and down the reverse control lever several times to obtain a proper position.</p>

HOW TO ASSEMBLE	ILLUSTRATION	REMARKS
<p>○ Fixing the spring to the spring suspension bracket</p> <p>Put one end of the spring into an anchoring hole in the connecting arm and the other end over the spring suspension bracket, push the spring suspension bracket forward until its setscrews are aligned with those of the crank, and tighten the setscrews and the fastening screw in this position.</p> <p>* When you put the spring end into the anchoring hole, hold up the other end of the spring (hooked end) to make your work easier.</p>		<p>When fastening the connecting arm and the spring suspension bracket to the shaft, tighten their screws by pushing them to the left, in order to prevent the spring from coming off or giving an excessive load on the reverse control lever.</p>

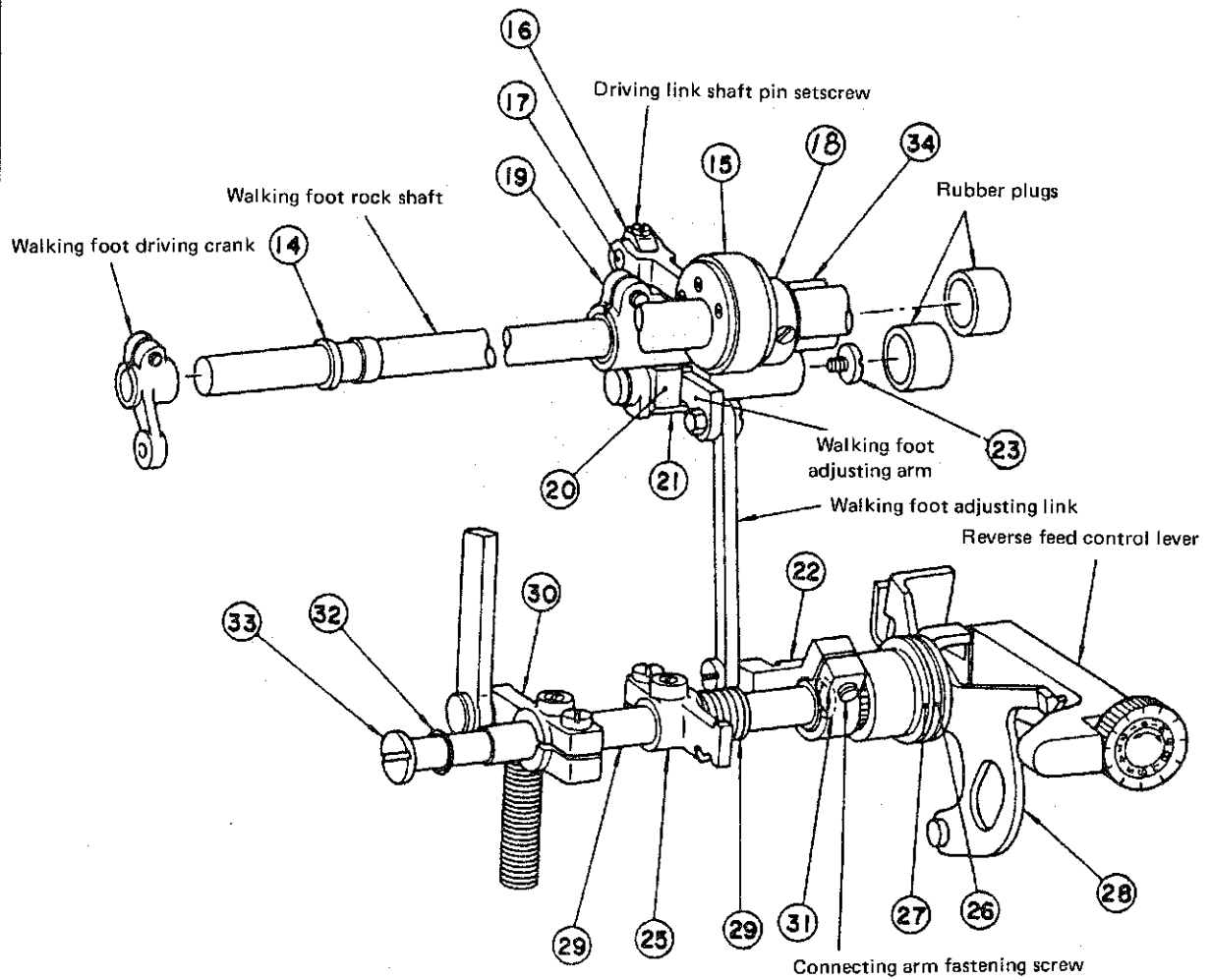

3. HOW TO REMOVE EXCESSIVE PLAY AND JARRING

In order to operate the machine smoothly and efficiently, you must remove excessive play and jarring from the following components.

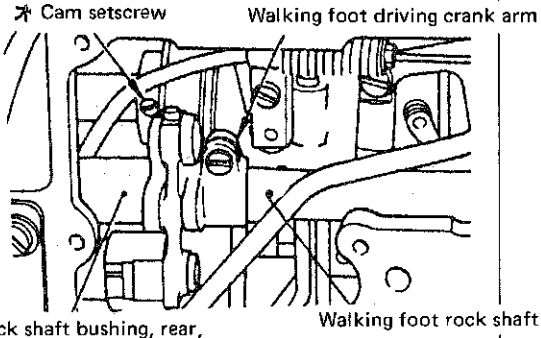
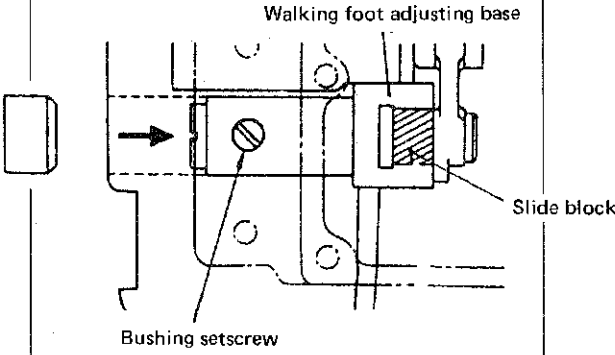
COMPONENTS AND METHODS	ILLUSTRATION	REMARKS
<p>(1)Walking foot rock shaft Loosen two cam setscrews and one screw which fastens the walking foot driving crank arm, and the walking foot rock shaft will be able to move freely in the axial direction. Push the shaft in the direction of its bushing (front) as far as it will go (stops with a click) and fasten the walking foot driving crank arm as you pressing it against the rock shaft bushing (rear).</p>		<p>Use a screw driver (large) and firmly tighten the screw to fasten the walking foot driving crank arm.</p>
<p>(2)Walking foot adjusting base (Notes) Do this only after the play in the walking foot rock shaft has been removed. Release the bushing by loosening its setscrew and carefully tap on either side of the walking foot adjusting base or the back of the machine arm so that the bushing permits the slide block to move smoothly without providing any play sideways, and tighten the setscrews.</p>		<p>It is advisable to keep the cam setscrew loosened during this adjustment, because it makes you judge easily if the slide block is jarring or not. In order to prevent the bushing setscrew from loosening during operation, tighten it very carefully.</p>

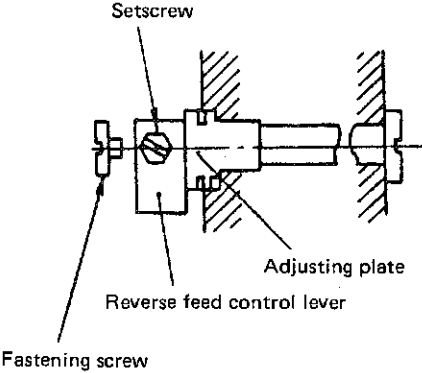
COMPONENTS AND METHODS	ILLUSTRATION	REMARKS
<p>(3)Reverse feed shaft Tighten temporarily the reverse feed control lever setscrew into the V-groove on the reverse feed shaft and fasten the shaft by tightening the fastening screw (SS-7620750-SP). By so doing, the reverse feed shaft does not have any play in the axial direction and accordingly does not allow the adjusting place to move at all.</p> <p>○ In the above state of the reverse feed shaft, loosen gradually the reverse feed shaft fastening screw until the adjusting plate can more smoothly and firmly tighten the setscrew of the reverse feed control lever using a hex. spanner.</p>		<p>This adjustment must be made after loosening the screws of the crank, spring suspension bracket, and connecting arm. After excessive plays have been removed from the reverse feed shaft, tighten these screws taking care not to hinder the smooth operation of the shaft and the reverse feed control lever.</p>

4. ADJUSTMENT OF THE TOP FEED DRIVING MECHANISM

- After the top feed driving mechanism has been assembled as described in the preceding paragraph, adjust it as follows :

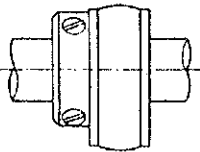
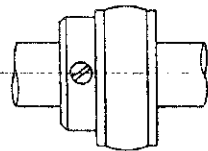
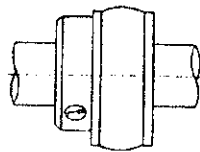
ADJUSTMENT	ILLUSTRATION
<p>(1) Position of cam ⑩ (See. Standard Adjustment ⑩)</p> <p>* The cam plays an important role in determination of the feed timing between the top and bottom feed mechanism. As already described in the Standard Adjustment ⑩ , the No. 1 setscrew of the cam must be in line with the axis of the main shaft when the need bar has come down to a level 14.9 mm above the throat plate surface. The No. 1 setscrew tightened in a wrong position causes the following troubles :</p> <p>a)  (No. 1 setscrew is above the main shaft axis)</p> <p>The top feed mechanism starts working prior to the bottom feed mechanism and starts withdrawing earlier than the bottom feed mechanism, making the gathering stitch ineffective.</p> <p>b)  (No. 1 setscrew is in line with the main shaft axis.)</p> <p>Normal position; A synchronous motion of the top and bottom feed is performed.</p> <p>c)  (No. 1 setscrew is below the main shaft axis.)</p> <p>The top feed mechanism starts working after the bottom feed mechanism has already started and the former is still working even after the latter has already stopped. This may damage the fabric surface.</p>	<p style="text-align: right;">→</p> <p>go HERE NEXT #2 PAGE 26</p>

ADJUSTMENT	ILLUSTRATION
<p>(2) Position of the connecting arm</p> <p>* Stroke of the top-feed mechanism in the horizontal direction depends on the position of the connecting arm. Therefore, you must carefully set the connecting arm in the following order ;</p> <p>1) Set the machine ;</p> <p>(a) Stitch dial at "5".</p> <p>(b) Gathering stitch dial at "5-7".</p> <p>(c) Top-feed indicating plate ^{Pointer} to "maximum-value". 5/7</p> <p>(d) Set the connecting link at the lowest point of the oval hole in the walking foot driving link.</p> <p>2) With the above-mentioned setting ;</p> <p>How to Set the top-feed plate ^{Pointer} for "0" on INDICATING PLATE .</p> <p>(reverse feed control lever is approximately in the horizontal position).</p> <p>Loosen the fastening screw of the walking foot driving crank and tighten it temporarily when the pin in the walking foot arm bracket arrives in the middle of the opening in the walking foot mount.</p> <p>3) Set the stitch dial for "5".</p> <p>Insert a screw driver between the walking foot driving crank arm and the adjusting arm and press them against each other, and the slant of the feed driving rocker will very. As you move upward the line engaged on the feed driving rocker, the amount of top feed is increased in the horizontal direction. As you move it downwards, the same effect is provided for the reverse feed.</p> <div data-bbox="231 1691 686 1993"> <p>Top-feed amount increases (forward feed)</p> <p>Top-feed amount increases (reverse feed)</p> </div>	<div data-bbox="782 448 1468 940"> </div> <div data-bbox="750 1052 893 1209"> <p>REF. # 7 Page # 14 PARTS BOOK 1982-7</p> </div> <div data-bbox="909 1075 1165 1276"> <p>Nut</p> </div> <div data-bbox="1005 1276 1452 1388"> <p>AFTER Adj. HERE, GO BACK TO PAGE SEVEN (7) Adj. # 11</p> </div> <div data-bbox="766 1400 1436 1769"> <p>Pin in the walking foot arm bracket</p> <p>Walking foot mount</p> </div>

ADJUSTMENT	ILLUSTRATION
<p>Raise the presser foot by the hand lifter, adjust the slant of the feed driving rocker by turning the handwheel so that distance "B" becomes 6.5 mm (1/4") (difference between the walking foot is in the front end and the rear end of its stroke) and fasten the connecting arm by inserting a screw driver through an adjusting hole located under the side plate.</p> <p>* If distance "B" is too great, the top-feed components hit other parts. If it is too small, effect of gathering stitch is reduced.</p> <p>(3) Longitudinal positioning of the walking foot</p> <p>After the adjustment has been made for the connecting arm, bring the walking foot back to the rear end of its stroke, loosen the fastening screw of the walking foot driving crank, move the walking foot mount to make distance "B" to about 10.7 mm (27/64") and fasten the walking foot driving crank.</p> <p>* If distance "B" is too great or too small compared to the standard of 10.7 mm, parts forming the top feed mechanism may hit the other components.</p>	

(4) Vertical phase of the top feed action

(See Standard Adjustment ⑨)

* If the walking foot rises too high or too low, you must properly adjust the vertical phase of the top feed action according to the Standard Adjustment ⑨ .

After all of the above-mentioned adjustments have been completed, run the machine at 3,500 s.p.m. and check if any unusual noise is made by the machine.

5. HOW TO INSTALL AND ADJUST OTHER COMPONENTS

(1) Reverse feed mechanism

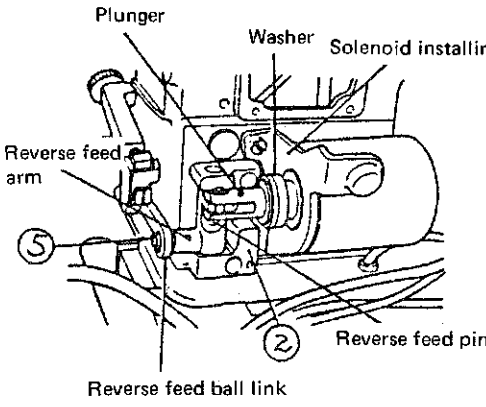
HOW TO ADJUST	ILLUSTRATION	REMARKS
<ol style="list-style-type: none"> 1) Fix reverse feed arm ③ and reverse feed pin ④ to reverse feed mounting base ② using screws. 2) Fasten reverse mounting base assembled by 1) and solenoid installing base asm ① together to the machine by temporarily tightening the screws. 3) Set the reverse feed mounting base in the way that its reverse feed pin is approximately in the vertical position. 4) Connect the reverse feed ball link to the reverse feed arm by means of work clamp foot connecting plate. 5) Set the stitch dial for "3" and turn the reverse feed control lever to "Reverse Feed" position, and fix the solenoid installing base (asm) in the appropriate position according to Standard Adjustment (13). 		<p>Fix the reverse feed pin using its flat face. If the reverse feed control lever becomes heavy after the solenoid assembly has been installed, it is usually caused by the eccentricity of the solenoid plunger. Correct the position of the solenoid assembly.</p>

(2) Wiper components

HOW TO ADJUST	ILLUSTRATION	REMARKS
<p>1) Attach the wiper magnet installing base to the machine arm by means of screw ①, which is used simultaneously to fasten the thread take-up lever cover, presser spring regulator nut ② and screw ③.</p> <p>2) Connect the top end of wiper driving plate (asm) to the wiper magnet plunger.</p> <p>3) Fix the wiper solenoid and the switch respectively to the wiper magnet installing base using their screws. Refer to Standard Adjustment (14) and (15) for positioning of the wiper solenoid.</p>	<p>The illustration consists of two parts. The upper part shows a side view of the wiper magnet installing base being mounted onto a metal machine arm. A screw, labeled ①, passes through the base and the arm. A second screw, labeled ③, is used to secure a 'Thread take-up lever cover' to the base. A presser spring regulator nut, labeled ②, is also shown being attached to the base. The lower part of the illustration shows the wiper magnet assembly in more detail. It includes a 'Wiper solenoid' (a rectangular box with a plunger) and a 'Switch' (a small electrical component) both mounted to the top of the wiper magnet installing base. The 'Wiper link' is connected to the plunger of the solenoid, and the 'Wiper driving plate' is attached to the end of the link.</p>	<p>When you additionally install the wiper components to a machine already in use, you must replace the original hand lifter (D1517-490-D00) by hand lifter (D1520-490-D00).</p>

(3) Pedal/knee presser-controlled gathering mechanism, PF-1

1) Outline of PF-1

Top feed amount depends on the position of the top-feed adjusting plate.

The top feed amount varies with the height of the top-feed adjusting plate; it increases as the hooked end of the adjusting plate is lowered, and it decreases as the adjusting plate is raised. Since the adjusting plate can be operated independent of the reverse feed control lever, it makes possible to change the top feed amount by keeping the bottom-feed at a constant rate.

The Pedal/knee presser-controlled gathering mechanism is designed to change only the top-feed amount by operating the pedal or the knee presser which is connected to the hooked end of the adjusting plate by means of a wire assembly.

(Notes) Refer to the separate Instruction Book for the details of installation and adjustment of PF-1.

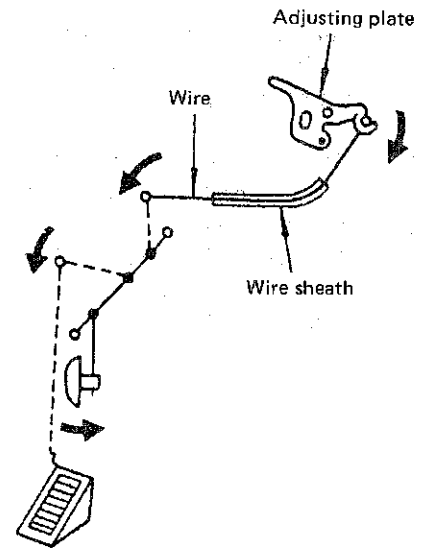
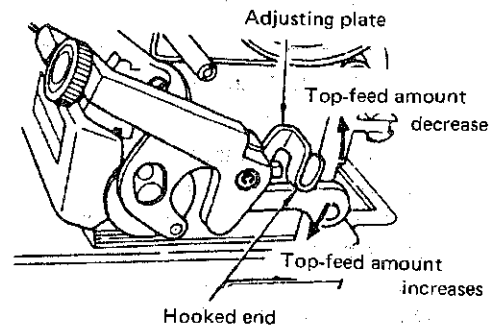

2) Installation of PF-1 on a machine stand other than JUKI Z type stand

It should be noted that the PF-1 is designed to install on JUKI Z type stand. When you install it on a JUKI H type stand, replace the pedal components according to the table shown in the next paragraph.

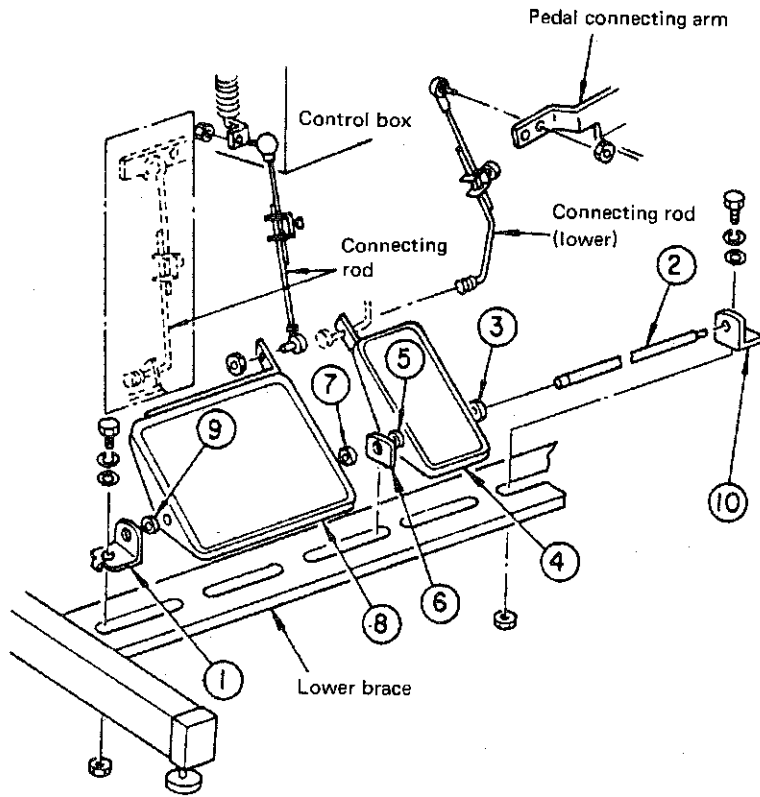

The pedal components for PF-1 are arranged in the stand as illustrated above. There are some machine stands of other makes which can not accommodate the specified large pedal. In such a case, install a large pedal and a small pedal suited to the stand and connect the former to the motor and the latter to the pedal connecting arm via the connecting rod (lower) supplied with a PF-1 unit.

3) Pedal components for PF-1 (JUKI stand)

Description	Z type stand	Q'ty	H type stand	Q'ty
Pedal shaft	GPF01016000	1	—	
Liner plate	GPF01017000	1	—	
Pedal	B8151771000	1	B8101232000	1
Pedal mat	B8152771000	1	—	
Pedal adjusting plate	B812528000E	1	B812528000	1
Pedal	D8110555B0E	1	B8105012000	1
Pedal mat	D8111555B0E	1	—	
Pedal adjusting plate	D8112555B0E	1	B8104012000	1
Pedal bushing	D8113555B0D	4	—	
Liner plate	D8114555B0E	2	—	
Screws	SM9082023SE	2	SM9061203SE	9
	WS0861401KR	2	NM6060001SE	5
	WP0871602SE	4	—	
	NM6080721SE	2	—	
	SM9061203SE	4	—	
	WS0621210KR	4	WS0521210KR	5
	WP0671016SE	4	WP0671016SE	5
	—	—	B8125012000	4
Pedal support arm	—			

If you install the PF-1 unit on a machine table other than the one which is specially designed for JUKI machine with thread trimmer and PF-1, make a recess in the table as shown below to fix the wire tube guide to it.

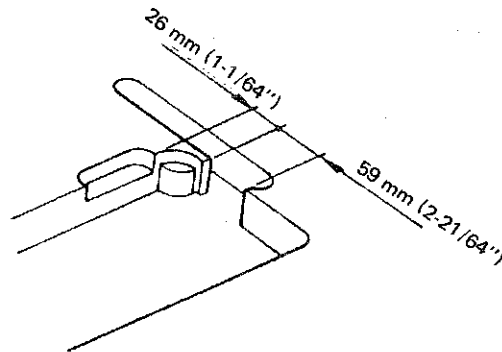

6. TROUBLES AND CORRECTIVE MEASURES

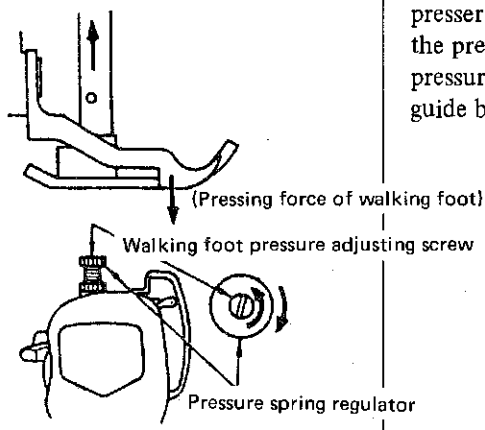
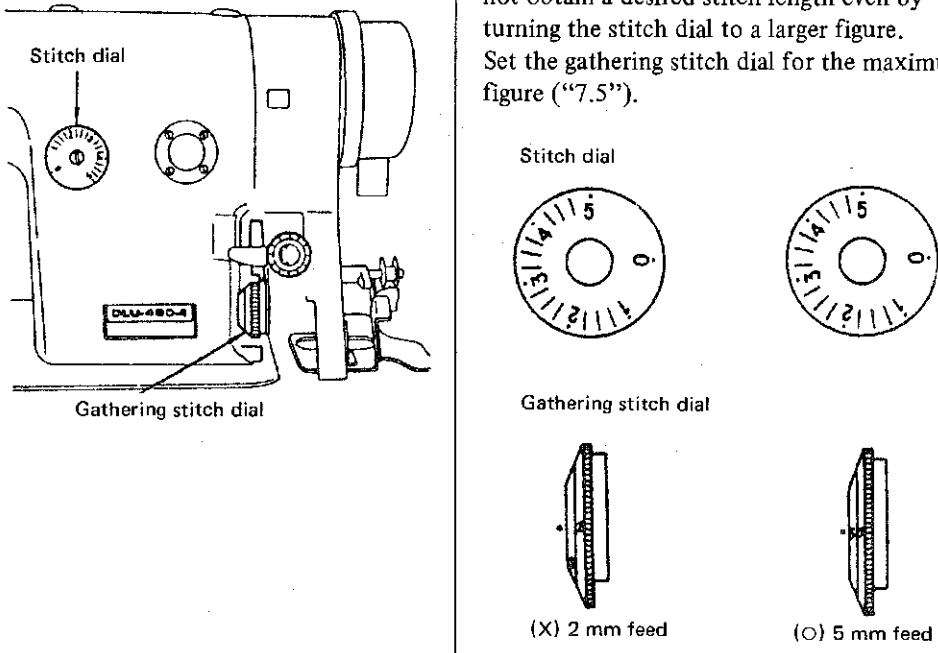
No.	TROUBLES	CAUSES	CORRECTIVE MEASURES
1	Cloth feed failure	<p>(1) Pressure of the walking foot is too high or pressure of the presser foot is too low.</p>  <p>(Pressing force of walking foot)</p> <p>Walking foot pressure adjusting screw</p> <p>Pressure spring regulator</p>	<p>Under such a circumstance like this, reaction of the walking foot pressure forces the presser foot to move slightly upwards especially the machine runs at a high speed. This causes a cloth feed failure. Turn the presser spring regulator clockwise to increase the pressure of the presser foot, or reduce the pressure of the walking foot by adjusting the guide bar.</p>
		<p>(2) The gathering stitch dial is set incorrectly.</p>  <p>Stitch dial</p> <p>Gathering stitch dial</p> <p>Stitch dial</p> <p>Gathering stitch dial</p> <p>(X) 2 mm feed</p> <p>(O) 5 mm feed</p>	<p>If the gathering stitch dial is set for a smaller figure than that of the stitch dial, you can not obtain a desired stitch length even by turning the stitch dial to a larger figure. Set the gathering stitch dial for the maximum figure ("7.5").</p>

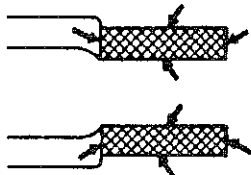
No.	TROUBLES	CAUSES	CORRECTIVE MEASURES
		(3)The presser bar does not move up and down smoothly.	Despite the presser spring regulator has been properly adjusted, the presser bar itself is twisted or seized up absorbing the tension applied by the spring. This causes the presser foot to fail to provide a necessary pressure to the workpiece to feed. Adjust the presser bar according to 2-(2).
		(4)The teeth of the walking foot or the main feed dog have worn out.	The worn teeth of the feed dog slip on the fabric and fail to feed it steadily. Replace the worn feed dog or walking foot.
2	Scratches on the fabric	<p>(1)The walking foot or the main feed dog has burrs on its edge.</p> 	Remove the burrs from the edge of the feed dog using a buffing wheel, taking care not to damage the feed dog teeth.
		(2)Pressure of the walking foot is too low or that of the presser foot is too high.	Under such conditions, the walking foot slips on the fabric to scratch. Adjust properly the relation of pressure between the walking foot and the presser foot according to Standard Adjustment (6).
		(3)Timing to raise the walking foot is too late.	Adjust the timing of the walking foot according to Standard Adjustment (9).

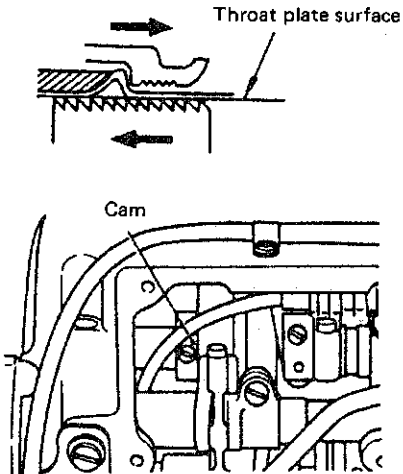
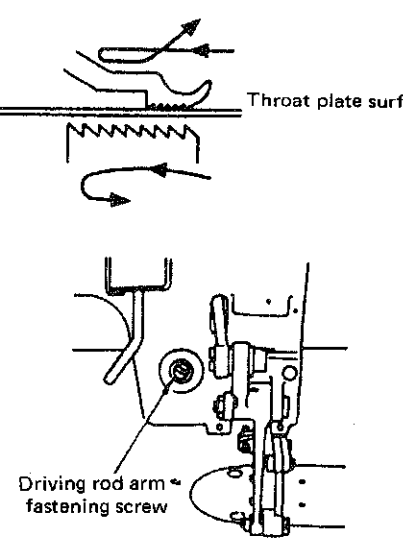
No.	TROUBLES	CAUSES	CORRECTIVE MEASURES
		<p data-bbox="475 360 895 421">(4)Timing of the horizontal motion of the walking foot is too early.</p> 	<p data-bbox="954 360 1433 551">The walking foot starts moving backwards while the feed dog is still feeding the fabric forwards. This causes the walking foot teeth to damages the surface of the fabric. Adjust the position of the cam according to Standard Adjustment (10).</p>
		<p data-bbox="475 1122 895 1182">(5)Timing of the vertical motion of the walking foot is too late.</p> 	<p data-bbox="954 1122 1433 1469">Timing of the walking foot to rise in its backward motion is too late. Loosen the driving rod arm fastening screw. Turn the handwheel forward until a feed motion has been completed permitting the presser foot to rest on the throat plate. In this state, push the walking foot link backwards (as arrow shows) by your finger to bring the roller into contact with the walking foot mount and tighten the driving rod arm fastening screw.</p>

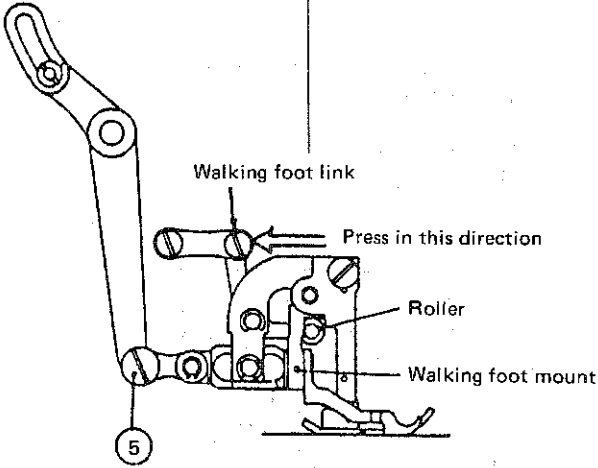
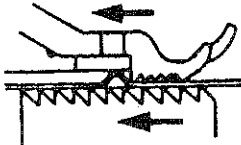
No.	TROUBLES	CAUSES	CORRECTIVE MEASURES
			
		<p>(6) Feed amount provided by the walking foot is too great.</p>	<p>Adjust the pressure of the walking foot in relation to the presser foot.</p>
3	<p>When gathering the top fabric, the bottom fabric is also gathered.</p>	<p>(1) Pressure of the walking foot is too high for the presser foot.</p>  <p>(2) The surfaces of the top and bottom fabric attract each other while being fed.</p>	<p>This permits the walking foot to act not only on the top fabric but on the bottom fabric. Reduce the pressure of the walking foot or increase the presser foot pressure. (Adjust to balance the two pressures)</p> <p>It is advisable to insert a separation plate (Z060) between the top and the bottom fabrics to eliminate their interaction.</p>

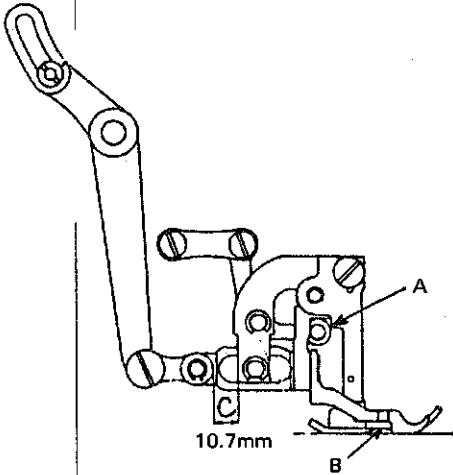
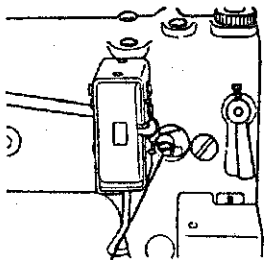
No.	TROUBLES	CAUSES	CORRECTIVE MEASURES
4	The top feed components hit the neighbouring parts.	<p>(1)The top feed components hit other parts when they are set for the maximum amount of feed.</p>   <p>Walking foot driving crank fastening screw</p>	<p>Check the following points with the maximum setting of the top feed amount;</p> <p>(1)Check that the horizontal stroke of the walking foot does not exceed 7 mm (9/32") when it is set for the maximum feed pitch. Adjust the position of the walking foot connecting arm according to 4-(2).</p> <p>(2)Check if it hits points A and B. In this case, adjust the position of the walking foot in the longitudinal direction.</p> <p>(3)Check that there is a 10.7 mm (27/64") clearance at point "C" when the walking foot is in the extreme backward position of its stroke. If this clearance is too great or too small, the walking foot will hit at point A or B. Loosen a fastening screw of the walking foot driving crank when the walking foot has gone back to the extreme end of its stroke, and adjust the clearance.</p>

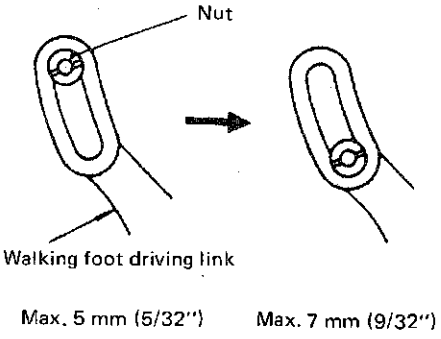
No.	TROUBLES	CAUSES	CORRECTIVE MEASURES
5	Workpieces are not fed straight.	(1) This happens only when S type gauge is used for gathering.	Since S type gauge is designed for sharp curve stitching, it is inferior to other types in straight stitch capability. Therefore, when gathering with a relatively large amount of feed, it is advisable to replace it by B type gauge.
		(2) Position of the walking foot is incorrect.	Adjust the position of the walking foot.
		(3) Pressure of the walking foot is too low or the presser foot pressure is too high.	Imbalance of the pressure hinders the walking foot from feeding the top fabric completely. Adjust the pressure of the presser foot and the walking foot.
6	Failure in gathering stitch	<p>(1) The walking foot driving link is connected at the highest end of its oval hole.</p>  <p>Max. 5 mm (5/32") Max. 7 mm (9/32")</p>	<p>Lower the connection point in the oval hole.</p> <ul style="list-style-type: none"> ○ Highest end : Max. 5 mm (13/64") ○ Lowest end : Max. 7 mm (9/32")

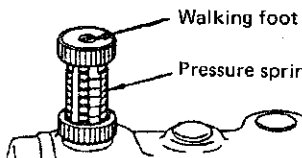
No.	TROUBLES	CAUSES	CORRECTIVE MEASURES
		<p>(2)The gathering stitch dial is set for the minimum value.</p>  <p style="text-align: center;">Gathering stitch dial</p>	<p>When the gathering stitch dial is set for the minimum, it limits the motion of the walking foot. Unless otherwise the gathering stitch is set for the minimum for the purpose of being a stopper for partial gathering, set it always at 7-5 (maximum figure).</p>
		<p>(3)The teeth on the walking foot have worn out.</p>	<p>Replace the walking foot.</p>
		<p>(4)Material of the workpiece is not suitable for gathering.</p>	<p>Use a separation plate (Z060).</p>
		<p>(5)Pressure of the walking foot is too low or pressure of the presser foot is too high.</p>  <p style="text-align: center;">Walking foot pressure adjusting screw Pressure spring regulator</p>	<p>Adjust the pressure relation between the walking foot and the presser foot.</p>
		<p>(6)A wrong gauge is installed on the machine.</p>	<p>Use a B type gauge for gathering.</p>
		<p>(7)The top feed components hit the neighbouring parts.</p>	<p>See the corrective measure described for Trouble 4.</p>

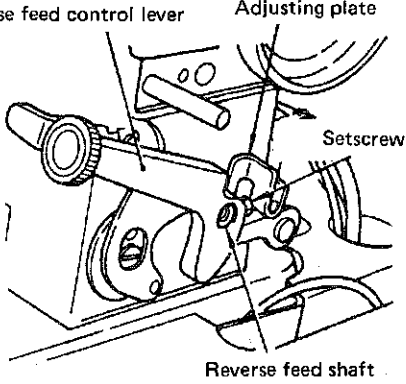
No.	TROUBLES	CAUSES	CORRECTIVE MEASURES
7	The reverse feed control lever does not come back smoothly to its original position.	<p>(1)The reverse feed control lever is rubbing against the adjusting plate.</p> 	Loosen a hex head screw which fastens the reverse feed control lever to the reverse feed shaft and provide a proper clearance at the adjusting plate.
		<p>(2)A spring between the spring suspension bracket and the connecting arm is not effective or disengaged.</p>	<p>If there is an excessive clearance between the spring suspension bracket and the connecting arm, it permits the spring to move away in the direction of "A" and disengages it from the connecting arm. As a result, the spring fails to return the top feed mechanism. Release the spring suspension bracket by loosening its fastening screw, insert one end of the spring into an anchoring hole in the connection arm and push the bracket in the direction "B".</p>

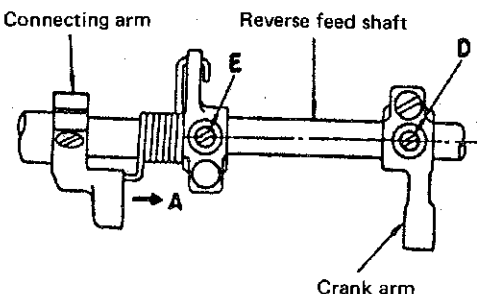
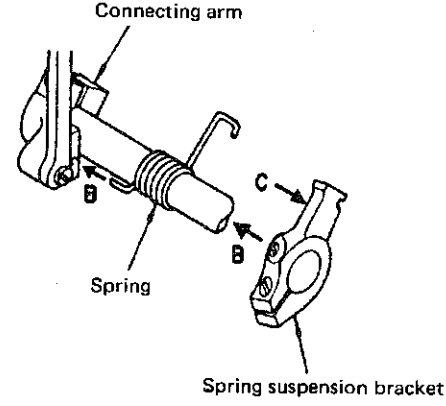
No.	TROUBLES	CAUSES	CORRECTIVE MEASURES
			 <p data-bbox="954 1348 1449 1505">As you pushing the bracket on section "C" using a screw driver and put on the spring. Align screw (E) in the bracket with screw (D) in the crank and fix the spring suspension bracket.</p>

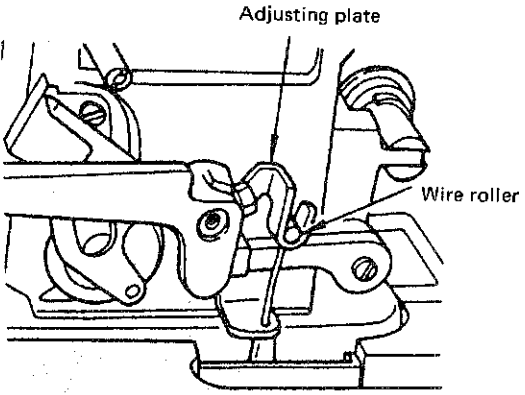
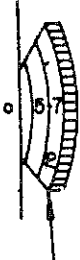
No.	TROUBLES	CAUSES	CORRECTIVE MEASURES
8	Pedal/knee presser-controlled gathering mechanism does not work properly.	<p>(1)The wire roller is not connected to the adjusting plate.</p> <p>(2)The gathering stitch dial is set incorrectly.</p>	<p>Connect them securely.</p>  <p>Adjusting plate</p> <p>Wire roller</p> <p>Set the gathering stitch dial correctly. If it is set for a small figure, a desired amount of gather is not provided.</p>  <p>Gathering stitch dial</p>
9	The fabric is scratched during reverse stitching.	(1)There is no play between the wire roller and the adjusting plate.	<p>As illustrated below, the adjusting plate is prevented by the wire roller from performing its action to reverse the feed direction. Provide a clearance between them by turning counterclockwise the stopper stud of the wire assembly after loosening its positioning nut which is accessible from the back of the machine table next to the switch box.</p>

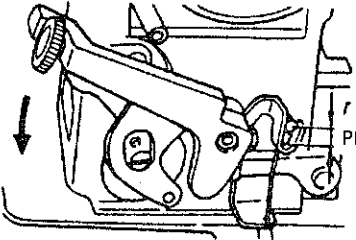
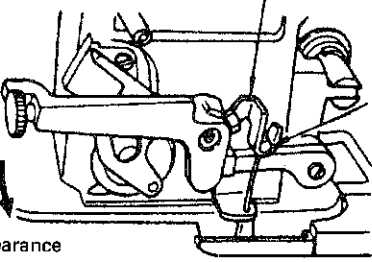
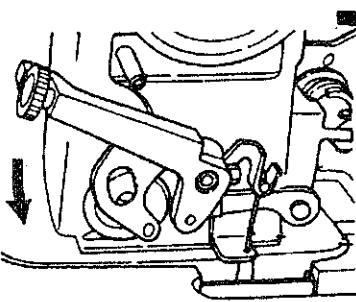
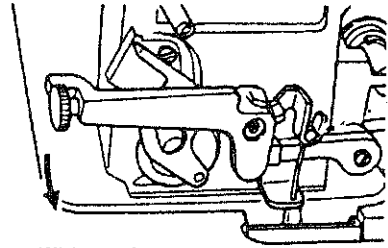
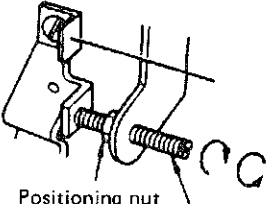
No.	TROUBLES	CAUSES	CORRECTIVE MEASURES
		<p data-bbox="517 573 754 600">In the forward feed state</p>  <p data-bbox="900 573 1129 600">In the reverse feed state</p>  <p data-bbox="1166 584 1313 611">Adjusting plate</p> <p data-bbox="1305 712 1409 739">Wire roller</p> <p data-bbox="900 853 994 880">Clearance</p>   <p data-bbox="967 1211 1141 1238">Without clearance</p>  <p data-bbox="810 1581 954 1608">Positioning nut</p> <p data-bbox="970 1615 1249 1641">Gathering stitch stopper stud</p>	<p data-bbox="962 371 1457 528">Set the stitch dial for 3 mm and the gathering stitch dial for 3 mm. Adjust the nut in the way that the wire roller touches the adjusting plate when the reverse feed control lever is turned for "reverse" stitching.</p>

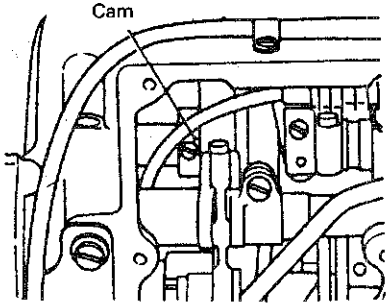
No.	TROUBLES	CAUSES	CORRECTIVE MEASURES
		<p>(2)Timing of the walking foot in the horizontal motion is incorrect.</p>	<p>Remove the side plate and adjust the cam according to 4(-).</p> 

7. USE OF DIFFERENT GAUGE SETS

Different types of gauge sets are available for model DLU-490 and each type is characterized as specified below;

[B type (standard gauge)]

(Use) General runstitch, gathering stitch etc.

(Features) Pull-in type presser. Suited for gathering and capable of compensating the slipping of top fabric on the bottom fabric in a very wide range. Best suited for slippery or problem fabrics.
Use of a separation plate (Z060) promotes the gathering efficiency.

(Hints for adjustment)

- Gathering capability depends largely on the balance of the pressure given by the walking foot and the presser foot.
 - a) When the pressure of the walking foot is too low;
Influence of the walking foot is reduced, making the gathering amount smaller.
 - b) When the pressure of the presser foot is too great;
The tension of the spring of the top feed mechanism acts on the presser foot to raise. Therefore, while the machine runs at a high speed, the presser foot will “float” causing the stitch to jam.

[D type]

(Use) Sharp curve stitch

(Features) Puller type. Designed for sharp curve stitching.

(Hints for adjustment)

- Unlike the B type gauge, this is a puller type gauge which pulls the workpiece beyond the needle and is not suitable for gathering or easing fullness.
If top feed amount is increased too much, it may break the textile yarns.
- Note that the maximum feed pitch is 5 mm (13/64”).

[E type]

(Use) For stitching fluffy fabrics

(Features) In order to prevent the walking foot from being entangled with the fluffy fabric during stitching, this presser foot is designed to act on the fabric in the way that it encloses the walking foot having the same shape as B type gauge.

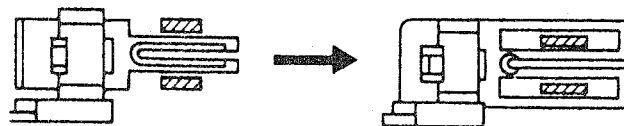

- Note that E type gauge is not suitable for gathering.

[S type]

(Use) Sharp curve stitch and prevention of puckering

(Features) Capable of puckering prevention.

Combination of designs of B type and D type.

(Hints for adjustment)

- Hints described for D type are applicable.
This type is not suitable for gathering and easing fullness.

[J and P types]

(Use) J type gauge : Zipper sewing (right-hand side)
P type gauge : Zipper sewing (left-hand side)

(Features) Capable of preventing the stretching fabrics from curling or twisting during stitching.

(Hints for adjustment)

- Hints described for B type gauge are applicable.
- In the original design, the distance from the center of the needle hole to the guide face of the presser foot is 3 mm. However, when necessary, this distance can be reduced to up to 2 mm by grinding the guide face.
- Note that the maximum top feed amount is 5 mm (13/64") and the maximum sewing speed is 4,000 s.p.m.

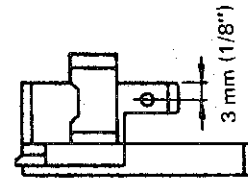

[M type]

(Use) Hemming

(Hints for adjustment)

- The presser foot of M type gauge is designed for use after removing area "A" according to the type of binder to be used together. Remove area "A" in the way to provide a 0.5 mm clearance between the guide face of the presser foot and the binder set in place.
- If hem is not rolled.
 - a) Move edge "B" to the left.
 - b) Top feed amount is too small or too great.
Adjust the stroke or pressure of the walking foot in relation to the presser foot.
- Unlike the binders of other makes, JUKI's binder specially designed for model DLU-490 has a low ceiling so that puckering with hemming and entrance of fabric between the walking foot and the presser foot are prevented. When a binder of other trade name is used, it may cause the above-mentioned troubles.
- For hemming applications, the necessary top-to-bottom feed ratio can be obtained within a range of 1:1 to 1:1.5. Take care not to increase the top feed amount too much.
- Note that the maximum top feed amount is 5 mm and the maximum sewing speed is 4,000 s.p.m.

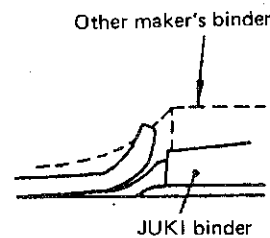
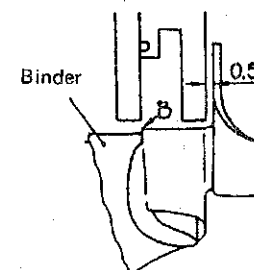
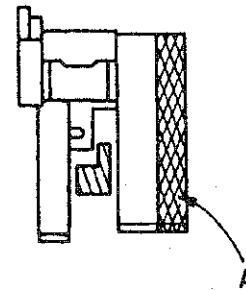

[N and L types]

(Use) L type gauge : For binding
N type gauge : For piping

(Hints for adjustment)

Refer to S type for N type gauge and D type for L type gauge, respectively.

- These L and N type gauges are prepared by our Attachment Center to meet each user's specifications. Write to Attachment Center for further details.

JUKI
TOKYO JUKI INDUSTRIAL CO., LTD.

Address : 23-3, Kabuki-cho 1-chome, Shinjuku-ku,
Tokyo 160, Japan
Cable : JUKI TOKYO
Telex : J22967, 232-2301
Phone : 03 (205) 1188, 1189, 1190