

# FA-V71A, V72A

パーツブック  
PARTS BOOK

---

超高速1本針上下調節送りオーバーロックミシン  
HIGH SPEED SINGLE NEEDLE ADJUSTABLE TOP AND BOTTOM FEED  
OVERLOCK SEWING MACHINE

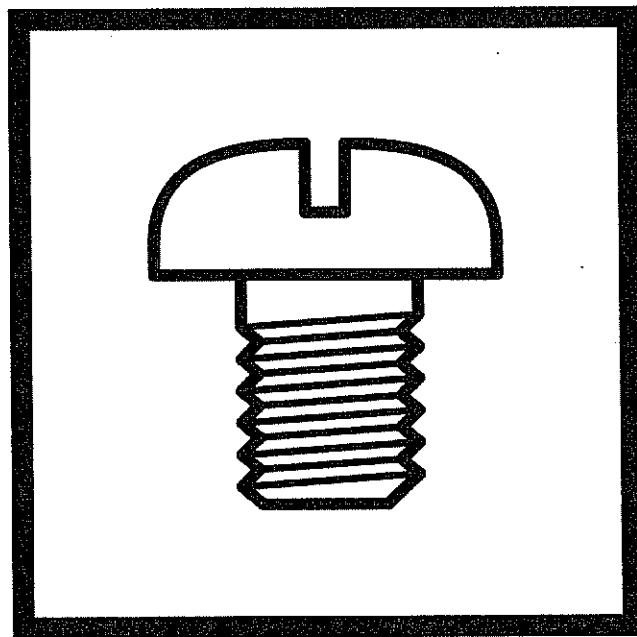

---

brother®

BROTHER INDUSTRIES, LTD. NAGOYA JAPAN

FA-V71A- ①②③④-⑤⑥

仕様 / Specifications

装置 / Devices

⑦⑧⑨

仕様明細 / Detail of specifications

①	縫い目形式 / Stitch form
2	1本針縁かがり・2本糸 Single needle over-edge chain stitch, 2-threads
3	1本針縁かがり・3本糸 Single needle over-edge chain stitch, 2-threads

⑥	かがり幅 / Stitch width
3	3 mm
4	4 mm
5	5 mm
6	6 mm
7	7 mm

②	用途 / Applications
0	地縫い / Plain seaming
4	ひだ取り / Shirring
6	パイピング付ひだ取り / Shirring with piping

⑦	上ループリフト / Over-looper locus
H	ハイリフト / High lift
E	超ハイリフト / Extra high lift

③	縫製物 / Sewing materials
1	極薄物～薄物 / Extra light - light materials
2	薄物～中厚物 / Light - medium materials
3	中厚物～厚物 / Medium - heavy materials
4	厚物～極厚物 / Heavy - Extra heavy materials
5	極厚物 / Extra heavy materials
6	バルキーニット / Bulky knit
7	極厚バルキーニット / Extra heavy bulky knit

⑧	差動送り歯 / 針板チェンランド / Differential feed dog
2	2列 / チェンランドあり 2-row / with chain land
3	3列 / チェンランドあり 3-row / with chain land
7	2列 / チェンランドなし 2-row / without chain land
8	3列 / チェンランドなし 3-row / without chain land

④	特殊用途 / Special use
0	標準 / Standard
1	小回り仕様 / Small type

⑤	針幅 / Needle gauge
0	1本針 / Single needle

⑨	上メス形状 / Upper knife shape
F	平メス / Flat knife
A	角メス / Angle knife
V	角メス波刃 / Angle knife, wave shape

## パーツブックご利用に際して

1. この本は、この本の表紙(正誤表の挿入されている場合は正誤表)に記載されているものと同じプレートが取り付けられているミシンのためのものです。
2. この本は、1999年7月のデータに基づいて作成されたものです。
3. 部品は予告なしに設計変更される場合があります。
4. 組単位で補給する部品は、[ ] 破線で示しております。
5. 部品コード欄が※となっている場合は、ゲージ部品一覧表(45ページ)でお調べ下さい。

## 目 次

A. 主体関係 .....	1
B. 駆動軸関係 .....	5
C. 針棒関係 .....	7
D. 押工関係 .....	9
E. 送り関係 .....	13
F. 上送り関係 .....	17
G. 上メス・下メス関係 .....	21
H. 上ルーパ関係 .....	23
J. 下ルーパ関係 .....	25
L. 給油潤滑関係 .....	27
M. 糸調子関係 .....	31
P. 針冷却関係 .....	33
Q. 縁カガリ定規関係 .....	33
R. ラフラー装置関係 .....	35
Z. 付属品関係 .....	41
Ga. ゲージ部品一覧表 .....	45
Wa. 警告ラベル .....	46
索引 .....	47

## Notes for using this parts book

1. This book is applicable to sewing machines which have the same plate number as shown on the cover of this book (or correction sheet).
2. This book was prepared based on information available in July 1999.
3. Parts are subject to changes in design without prior notice.
4. Parts supplied as complete assemblies are circled by a dotted line [ ] .
5. If the symbol ※ is found in the "Parts No." column, refer to the different parts list on page 45 .

## CONTENTS

A. Machine body .....	1
B. Crankshaft mechanism .....	5
C. Needle bar mechanism .....	7
D. Presser foot mechanism .....	9
E. Feed mechanism .....	13
F. Upper feed mechanism .....	17
G. Knife mechanism .....	21
H. Over looper mechanism .....	23
J. Under looper mechanism .....	25
L. Lubrication .....	27
M. Thread tension .....	31
P. Needle cooler .....	33
Q. Serging attachment .....	33
R. Ruffling attachment .....	35
Z. Accessories .....	41
Ga. Gauge parts List .....	45
Wa. Warning labels .....	46
INDEX .....	47



A. 主体関係 / Machine body

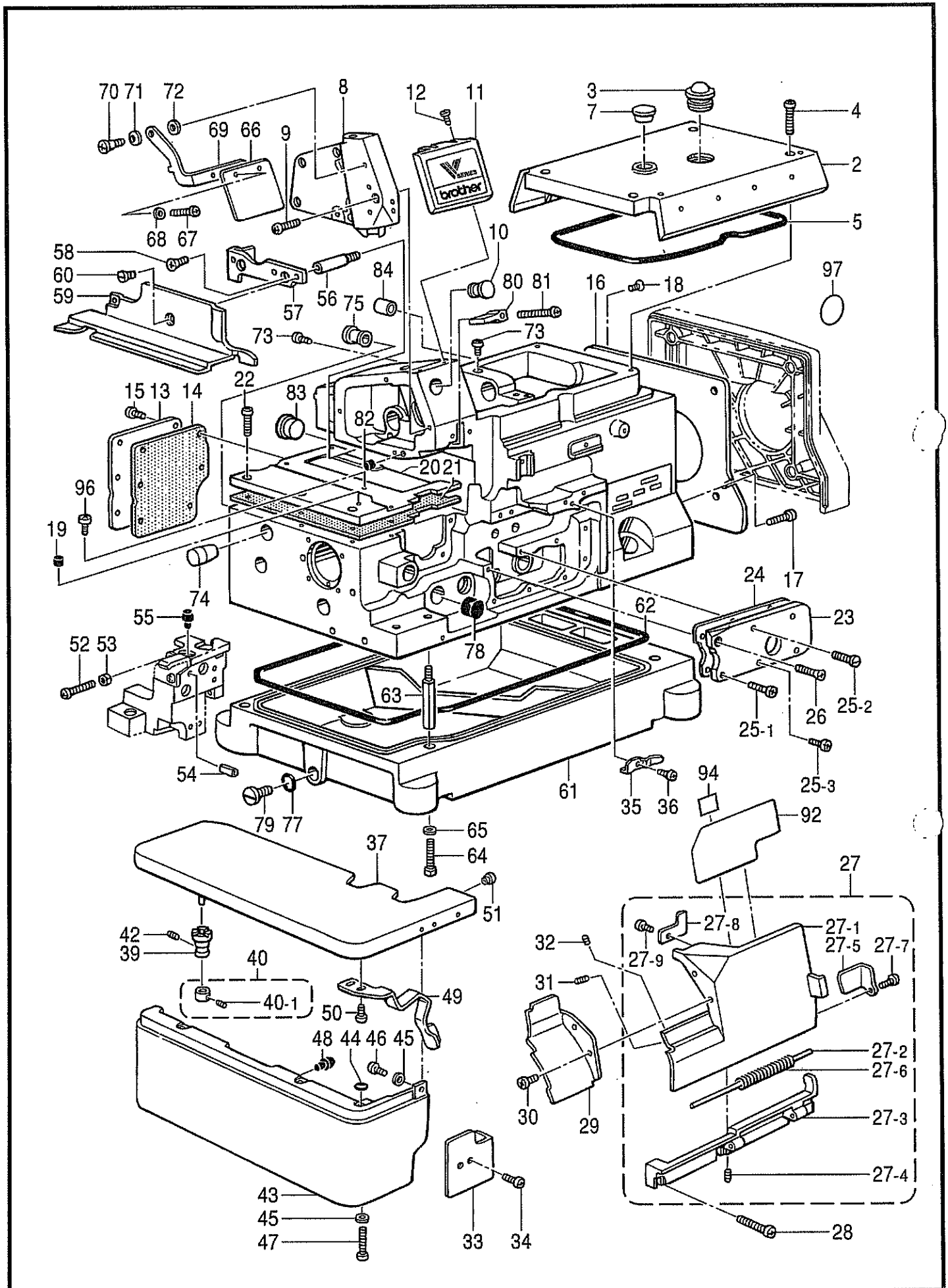

## A. 主体関係 / Machine body

REF.NO.	CODE	Q'TY	ヒンメイ	NAME OF PARTS	RM
2	S20204001	1	ウツカバー	TOP COVER	
3	S02606000	1	ユリヨウケイマド	OIL GAUGE WINDOW	
4	062401212	4	ナベコ4X12	SCREW, PAN M4X12	
5	S20306000	1	パツキン	PACKING	
7	S23337009	1	ゴムセン18.5	RUBBER CAP, 18.5	
8	S39607001	1	ソクメンカバー	FRAME SIDE COVER	
9	062400812	4	ナベコ4X8	SCREW, PAN M4X8	
10	S20345009	1	ゴムセン14	RUBBER CAP, 14	
11	S20309101	1	メンイタカバー	FACE PLATE COVER	
12	060400612	2	バインドM4X6	SCREW, BIND M4X6	
13	S20310001	1	オクリキコウカバーB	COVER FOR FEED MECHANISM, B	
14	S20311000	1	パツキン	PACKING	
15	060400812	6	バインドM4X8	SCREW, BIND M4X8	
16	S23367001	1	ファンカバー	FAN COVER	
17	060400812	2	バインドM4X8	SCREW, BIND M4X8	
18	061400812	1	サラコM4X8	SCREW, FLAT M4X8	
19	S20878000	1	ゴムセン5.3	RUBBER CAP, 5.3	
20	S20313000	1	オクリダイカバー	FEED BAR COVER	
21	S20314000	1	パツキン	PACKING	
22	062401012	6	ナベコM4X10	SCREW, PAN M4X10	
23	S39564021	1	ウチカバー	INSIDE COVER	
24	S44536000	1	ウチカバーパツキン	PACKING, INSIDE COVER	
25-1	060401012	3	バインドM4X10	SCREW, BIND M4X10	
25-2	S23616101	1	シメネジ4X10	SCREW, M4X10	
25-3	S44535001	1	バインドM4X8シール	SCREW, BIND M4X8 SEAL	
26	061400812	1	サラコM4X8	SCREW, FLAT M4X8	
27	S39611001	1	マエカバーLクミ	FRONT COVER ASSY, L	
27-1	S39612001	1	マエカバーL	FRONT COVER, L	
27-2	S39613001	1	マエカバーヒンジジク	FRONT COVER HINGE SHAFT	
27-3	S20319001	1	マエカバーヒンジ	FRONT COVER HINGE	
27-4	012400432	2	アナヒラ4X4	SET SCREW, SOCKET (FT) M4X4	
27-5	S20320101	1	マエカバーストツバ	FRONT COVER STOPPER	
27-6	S20321001	1	マエカバーバネ	FRONT COVER SPRING	
27-7	060400612	1	バインドM4X6	SCREW, BIND M4X6	
27-8	S20327101	1	マエカバートメイタ	STOPPER PLATE, FRONT COVER	
27-9	060400612	1	バインドM4X6	SCREW, BIND M4X6	
28	060401412	3	バインドM4X14	SCREW, BIND M4X14	
29	S20323101	1	マエカバーS	FRONT COVER, S	
30	062400612	2	ナベコM4X6	SCREW, PAN M4X6	
31	012400832	1	アナヒラ4X8	SET SCREW, SOCKET (FT) M4X8	
32	012400432	1	アナヒラ4X4	SET SCREW, SOCKET (FT) M4X4	
33	S20324101	1	マエカバーLアンナイ	FRONT COVER GUIDE, L	
34	060400612	2	バインドM4X6	SCREW, BIND M4X6	
35	S20325001	1	マエカバートメイタバネ	PLATE SPRING	
36	060400612	1	バインドM4X6	SCREW, BIND M4X6	
37	S20328001	1	クロスプレート	CLOTH PLATE	
39	S20330100	1	クロスプレートササエカラー	CLOTH PLATE SUPPORT COLLAR	
40	S20331001	1	セットカラークミ	SET SCREW COLLAR ASSY	
40-1	012400432	1	アナヒラ4X4	SET SCREW, SOCKET (FT) M4X4	
42	012400632	1	アナヒラ4X6	SET SCREW, SOCKET (FT) M4X6	
43	S20334000	1	クロスプレートシタ	CLOTH PLATE (LOWER)	
44	118770001	3	パツキン	PACKING	
45	025040132	4	ヒラザガネシヨウ4	WASHER, PLAIN S 4	
46	060400612	1	バインドM4X6	SCREW, BIND M4X6	
47	060401012	3	バインドM4X10	SCREW, BIND M4X10	
48	S20412000	2	ゴムセン3.7	RUBBER CAP, 3.7	
49	S39625151	1	クロスプレートトメイタバネ	SPRING, PLATE	
50	060400612	2	バインドM4X6	SCREW, BIND M4X6	
51	156482000	1	セン4	CAP, 4	

A. 主体関係 / Machine body

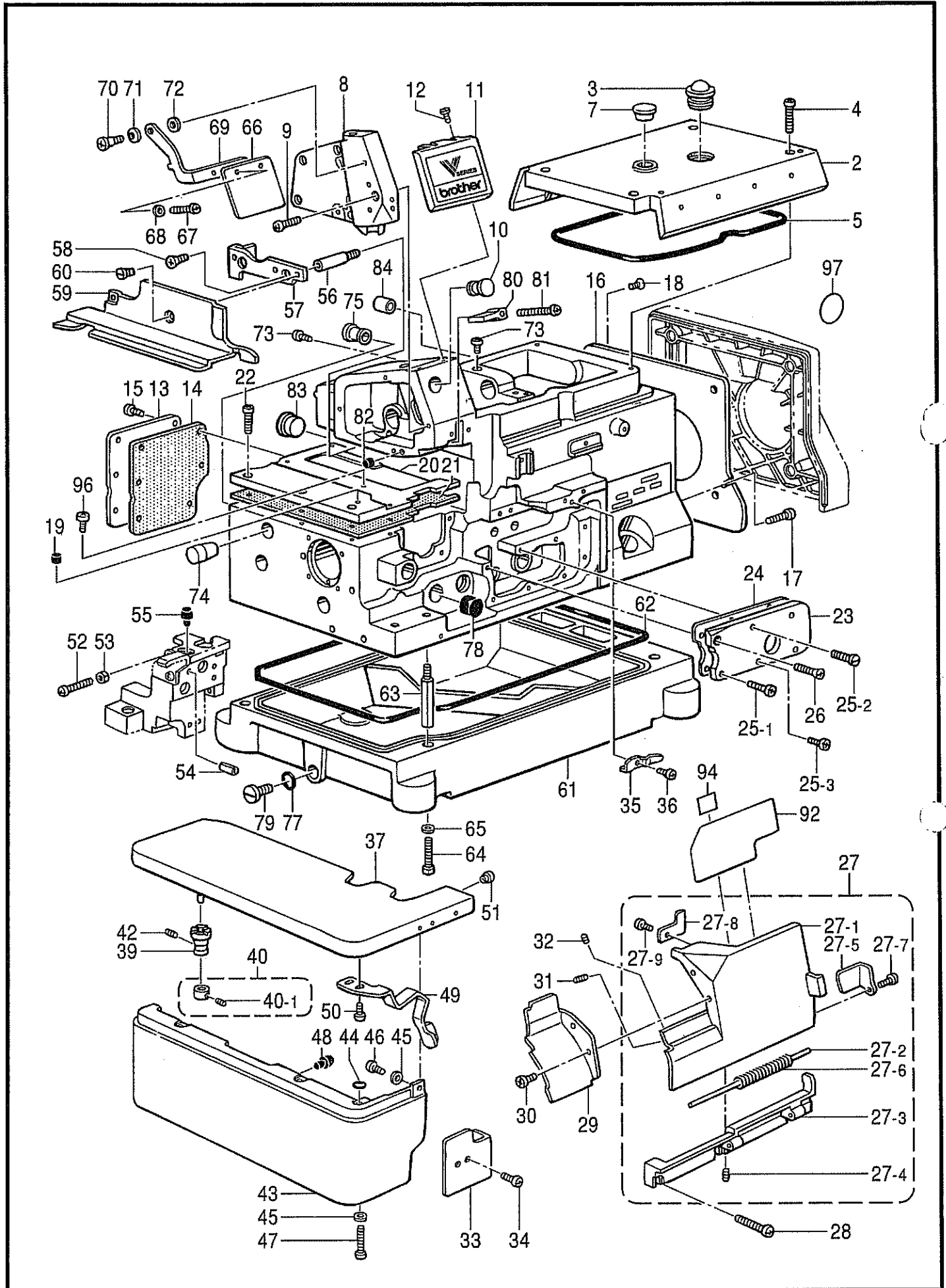



## A. 主体関係 / Machine body

REF.NO.	CODE	Q'TY	ヒンメイ	NAME OF PARTS	RM
52	062401212	1	ナベコ4X12	SCREW, PAN M4X12	
53	021400212	1	2シユナツト4	NUT, 2 M4	
54	047602042	1	スプリングピン6X20	PIN, SPRING ROLL 6X10	
55	S20412000	1	ゴムセン3.7	RUBBER CAP, 3.7	
56	S20208001	2	スタツド4	STUD, 4	
57	S20207101	1	ヌノアンナイトリツケイタ	CLOTH GUIDE SET PLATE	
58	061400812	2	サラコM4X8	SCREW, FLAT M4X8	
59	S20337001	1	クロスプレートヌノアンナイ	CLOTH GUIDE	
60	S23418002	2	シメネジ4X5	SCREW, M4X5	
61	S20338200	1	アブラウケ	OIL PAN	
62	S20339000	1	パツキン	PACKING	
63	S23350001	4	ホンタイシチユウ	MACHINE BODY LEG	
64	017501212	4	ボルト5X12	BOLT, M5X12	
65	S23351001	4	ザガネ	WASHER	
66	S00075000	1	アイガード	EYE GUARD	
67	060350812	2	バインド35X8	SCREW, BIND M3.5X8	
68	025350332	2	ヒラザガネダイ3.5	WASHER, PLAIN L 3.5	
69	S20340001	1	アイガードササエイタ	EYE GUARD SUPPORT PLATE	
70	S20342001	1	ダンネジ4	SHOULDER SCREW, M4	
71	146598001	1	バネザガネ	WASHER, SPRING	
72	025050132	1	ヒラザガネシヨウ5	WASHER, PLAIN S 5	
73	S30517101	5	ナベコシール6X10	SCREW, PAN M6X10 SEAL	
74	S20344009	1	ゴムセン16	RUBBER CAP, 16	
75	S20345009	1	ゴムセン14	RUBBER CAP, 14	
77	081009070	1	OリングP9	O RING, P9	
78	154841001	1	ゴムセン16.8	RUBBER CAP, 16.8	
79	S23357001	1	シメネジ10	SCREW, M10	
80	S20346000	1	ハリボウアブラウケ	NEEDLE BAR OIL RESERVOIR	
81	062401612	1	ナベコM4X16	SCREW, PAN M4X16	
82	S20878000	1	ゴムセン5.3	RUBBER CAP, 5.3	
83	S23337009	1	ゴムセン18.5	RUBBER CAP, 18.5	
84	S07477009	1	ゴムリング	RUBBER RING	
92	S25179001	1	<3本糸用> イトトオシセツメイラベルA	<FOR "3 THREADS"> THREADING DIAGRAM LABEL (A)	
92	S25180001	1	<2本糸用> イトトオシセツメイラベルB	<FOR "2 THREADS"> THREADING DIAGRAM LABEL (B)	
94	S44821001	1	セイソウシジラベル	LABEL, CLEANING	
96	060400512	1	バインドM4X5	SCREW, BIND M4X5	
97	S43453001	1	フィルタコウカンシジラベル	LABEL, CLEANING FILTER	

B. 駆動軸関係 / Driving shaft mechanism

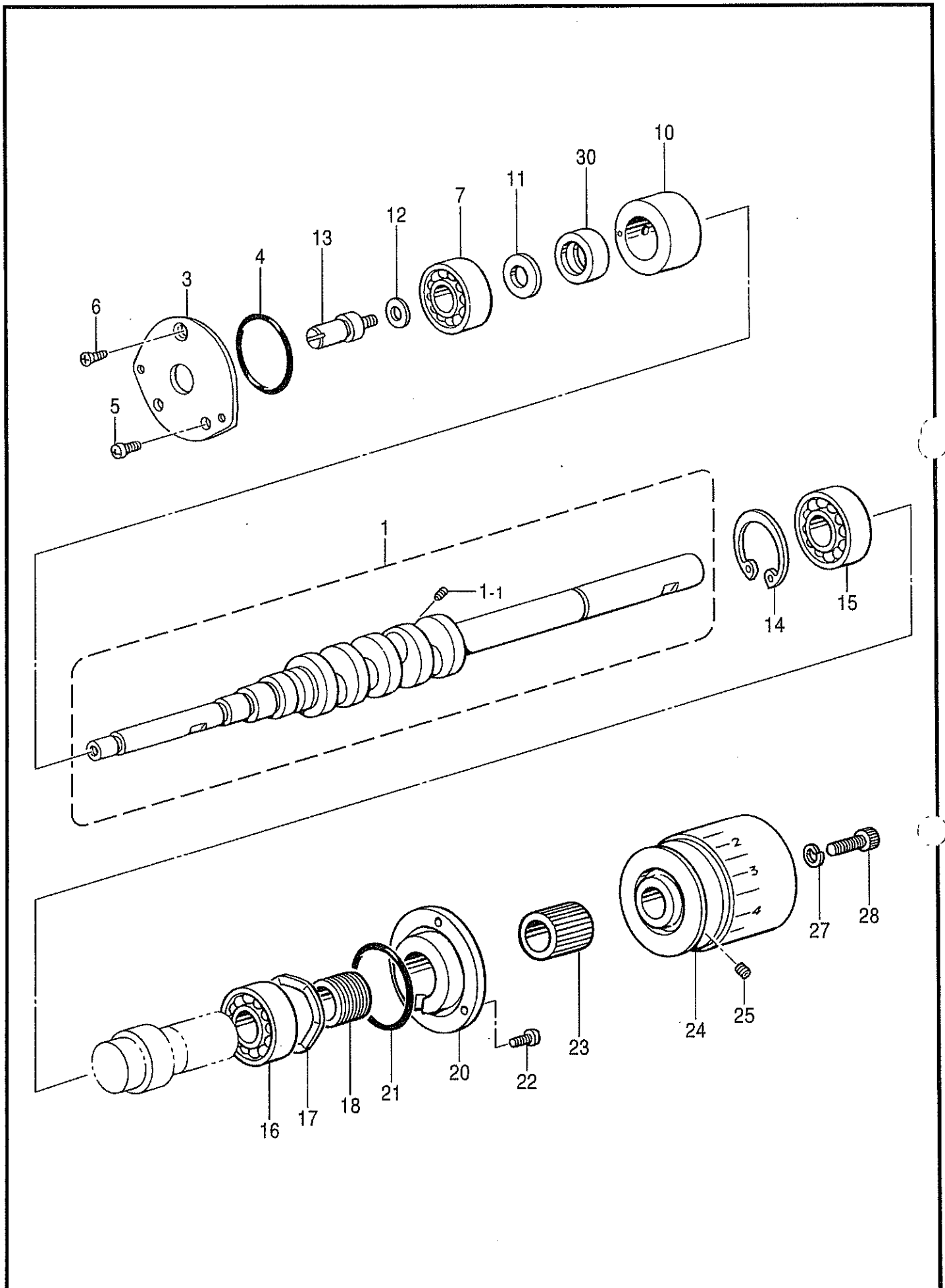

B. 駆動軸関係 / Crankshaft mechanism

REF.NO.	CODE	Q'TY	ヒンメイ	NAME OF PARTS	RM
1	S46923001	1	クドウジクQネジツキ	CRANKSHAFT, Q W/SCREW	
1-1	S25530001	1	アナクボミ2.5X4	SET SCREW, SOCKET M2.5X14	
3	S39629021	1	ベアリングフタ	BEARIG CAP	
4	081031870	1	Oリング S31.5	O RING S31.5	
5	062400812	2	ナベコ4X8	SCREW, PAN M4X8	
6	061400812	1	サラコM4X8	SCREW, FLAT M4X8	
7	072600000	1	タマジクウケ6000	BALL BEARING, 6000	
10	S39630000	1	クドウジクメタル	CRANK SHAFT BUSH	
11	S20356001	1	ヒラザガネ10	WASHER, PLAIN 10	
12	155559001	1	ヒラザガネ	WASHER, PLAIN	
13	S46900001	1	ニジユウカンテンピンジク	D-CHAIN STITCH THR.	
14	048400242	1	トメワアナヨウC40	RETAINING RING, C40	
15	076203000	1	タマジクウケ6203	BALL BEARING, 6203	
16	S27868001	1	タマジクウケ6203V	BALL BEARING, 6203V	
17	S20361001	1	ナミバネ	SPRING, WAVE	
18	S20362151	1	クドウジクオイルキリ	CRANK SHAFT OIL REJECTOR	
20	S39631000	1	ベアリングオサエ	BEARING PRESSER	
21	S20353000	1	Oリング	O RING	
22	062401012	3	ナベコM4X10	SCREW, PAN M4X10	
23	S34326000	1	ファンブツシュ	BUSHING, FAN	
24	S39565101	1	プーリ	PULLEY	
25	012060632	2	アナヒラ6X6	SET SCREW, SOCKET (FT) M6X6	
27	028060242	1	バネザガネ2-6	WASHER, SPRING 2-6	
28	018062532	1	アナホルト6X25	BOLT, SOCKET M6X25	
30	S20357000	1	ニジユウカンヘンシンカバー	CHAIN STITCH ECCENTRIC COVER	

C. 針棒關係 / Needle bar mechanism

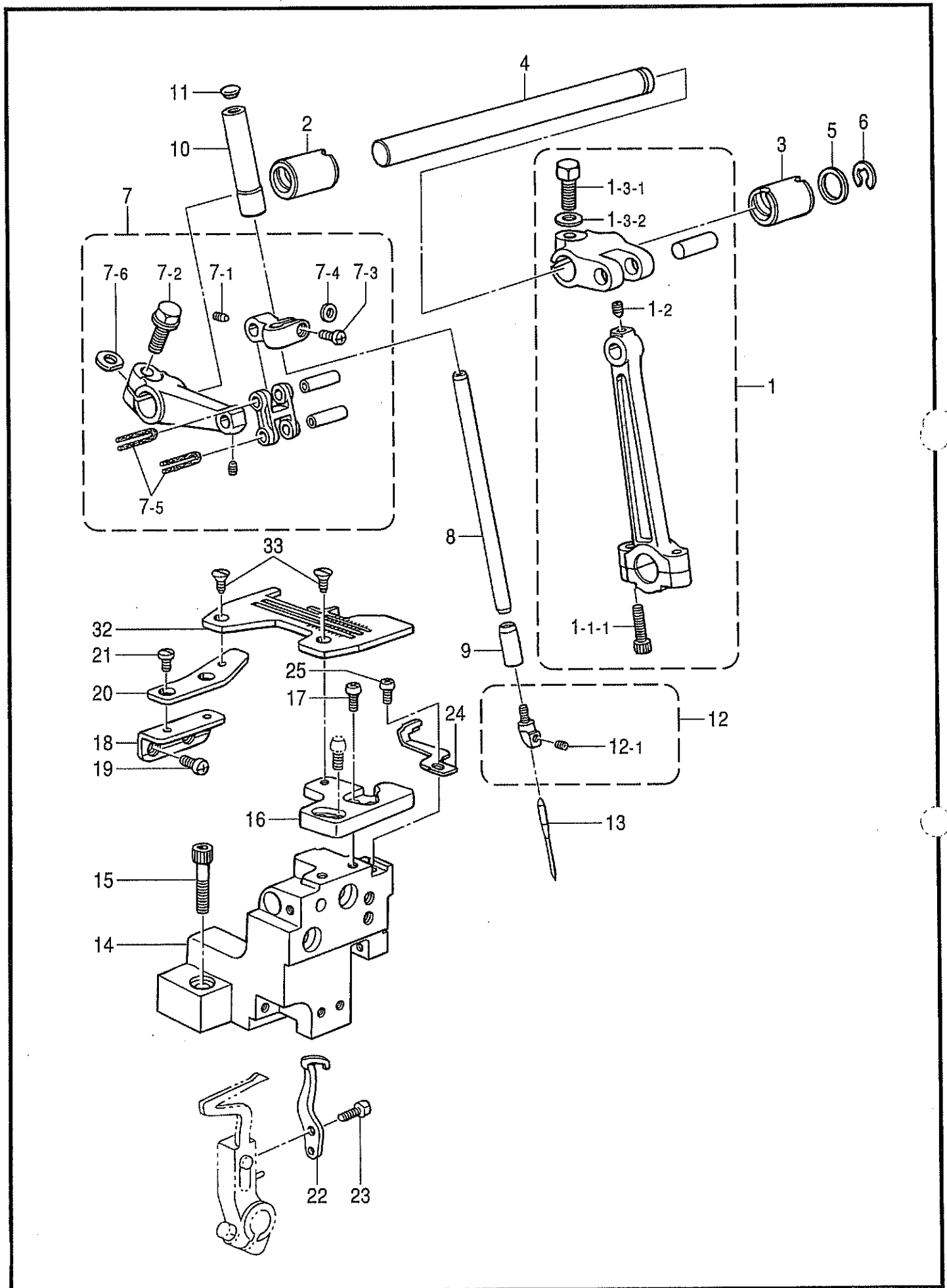

C. 針棒関係 / Needle bar mechanism

REF.NO.	CODE	Q'TY	ヒンメイ	NAME OF PARTS	RM
1	S46931001	1	<ハイリフト用> ハリ克蘭クロツドクミH	<FOR HIGH-LIFT> N-DRIVING CRANK ROD ASSY, H	
1	S46932001	1	<超ハイリフト用> ハリ克蘭クロツドクミE	<FOR EXTRA HIGH-LIFT> N-DRIVING CRNK ROD ASSY, E	
1-1-1	018401622	2	アナホルト4X16	BOLT, SOCKET M4X16	
1-2	S23342001	1	アナトガリ4X5	SET SCREW, SOCKET (CN) M4X5	
1-3-1	017061612	1	ボルト6X16	BOLT, M6X16	
1-3-2	118735002	1	ザガネ	WASHER	
2	S39644021	1	ハリジクメタルL	NEEDLE SHAFT BUSH, L	
3	S39645021	1	ハリジクメタルR	NEEDLE SHAFT BUSH, R	
4	S39646021	1	ハリジク	NEEDLE SHAFT	
5	S39647000	1	ザガネ	WASHER	
6	146293001	1	トメワE10	RETAINING RING, E10	
7	S20386101	1	ハリボウダクミ	NEEDLE BAR CLAMP ASSY	
7-1	S23342001	2	アナトガリ4X5	SET SCREW, SOCKET (CN) M4X5	
7-2	S46899001	1	ザガネツキボルト6X16	BOLT, (S/P WASHER) M6X16	
7-3	062350812	1	ナベコ3.5X8	SCREW, PAN M3.5X8	
7-4	S20391001	1	スペーサ	SPACER	
7-5	S20392000	2	フェルト	FELT	
7-6	155162001	1	スペーサ	SPACER	
8	S20393101	1	ハリボウ	NEEDLE BAR	
9	S39648021	1	ハリボウメタルD	NEEDLE BAR BUSH, D	
10	S39571021	1	ハリボウメタルU	NEEDLE BAR BUSH, U	
11	104450101	1	ゴムセンB	RUBBER CAP, B	
12	S20396001	1	ハリドメクミ	NEEDLE CLAMP ASSY	
12-1	146427001	1	アナトメネジ3.18クボミ	SET SCREW, SOCKET (CP) SM3.18	
13	※	1	ミシンハリDCX27	NEEDLE, DCX27	
14	S39649021	1	ハリイタササエダイ	NEEDLE PLATE SUPPORT BRACKET	
15	018062532	2	アナホルト6X25	BOLT, SOCKET M6X25	
16	S39650051	1	ハリイタササエイタF	NEEDLE PLATE SUPPORT, F	
17	062401012	2	ナベコM4X10	SCREW, PAN M4X10	
18	S20413051	1	ハリイタササエイタBササエ	SUPPORT, B N-PLATE SUPPORT	
19	062400612	2	ナベコM4X6	SCREW, PAN M4X6	
20	S20414001	1	ハリイタササエイタB	NEEDLE PLATE SUPPORT PLATE (B)	
21	S23418002	2	シメネジ4X5	SCREW, M4X5	
22	S20415101	1	イドウハリウケ	MOVABLE NEEDLE GUARD	
23	S20416101	1	ボルト3.5X10	BOLT, M3.5X10	
24	S39653051	1	ハリウケF	NEEDLE GUARD, F	
25	062350812	1	ナベコ3.5X8	SCREW, PAN M3.5X8	
32	※	1	ハリイタ	NEEDLE PLATE	
33	100032003	2	サラネジ4.37	SCREW, FLAT SM4.37	

D . 押工関係 / Presser foot mechanism

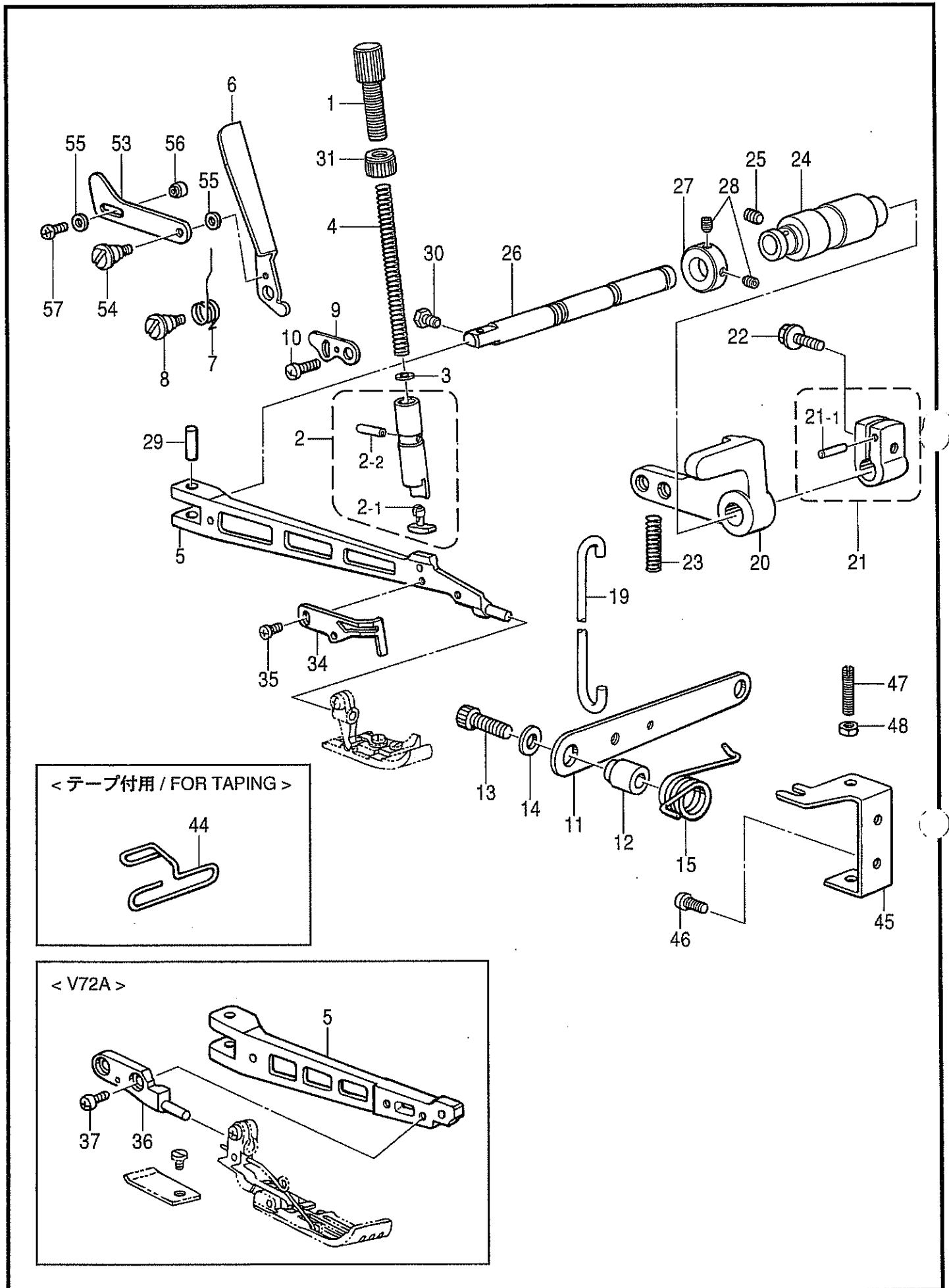

## D. 押工関係 / Presser foot mechanism

REF.NO.	CODE	Q'TY	ヒンメイ	NAME OF PARTS	RM
1	S20472001	1	オサエチヨウセツネジ	ADJUST SCREW	
2	S46887001	1	オサエボウクミ	PRESSER BAR ASSY	
2-1	S39577000	1	オサエクツシヨン	CUSHION	
2-2	047301642	1	スプリングピンAW3	PIN, SPRING ROLL AW3	
3	105161004	1	ザガネ	WASHER	
4	S20477001	1	オサエバネ	PRESSER SPRING	
6	S46840001	1	オサエテアゲ	PRESSER BAR LIFTER	
7	S39660001	1	オサエテアゲバネ	PRESSER BAR LIFTER SPRING	
8	S39661001	1	ダンネジ4	SHOULDER SCREW, M4	
9	S39662001	1	シユオサエウデストツバ	MAIN PRESSER ARM STOPPER	
10	060400612	1	バインドM4X6	SCREW, BIND M4X6	
11	S39663021	1	オサエアシアゲレバー	PRESSER FOOT LIFTER LEVER	
12	S39664001	1	オサエアシアゲレバーカラー	COLLAR	
13	018062532	1	アナホルト6X25	BOLT, SOCKET M6X25	
14	025060332	1	ヒラザガネダイ6	WASHER, PLAIN L 6	
15	S39665001	1	オサエアシアゲレバーバネ	SPRING	
19	S20485001	1	オサエアゲリンク	PRESSER BAR LIFTER LINK	
20	S20209001	1	オサエアゲレバー	PRESSER BAR LIFTER LEVER	
21	S46849001	1	オサエアゲウデクミ	PRESSER BAR LIFTER ARM ASSY	
21-1	047401642	1	スプリングピンAW4	PIN, SPRING ROLL AW4	
22	S46899001	1	ザガネツキボルト6X16	BOLT, (S/P WASHER) M6X16	
23	S20489001	1	オサエアゲレバーバネ	SPRING, PRESSER LIFTER LEVER	
24	S46839000	1	オサエウデジクメタル	PRESSER ARM SHAFT BUSH	
25	012060632	1	アナヒラ6X6	SET SCREW, SOCKET (FT) M6X6	
26	S39671101	1	オサエウデジク	PRESSER ARM SHAFT	
27	S39733001	1	セットカラー	SET SCREW COLLAR	
28	012400432	2	アナヒラ4X4	SET SCREW, SOCKET (FT) M4X4	
29	S39672001	1	オサエウデピン	PRESSER ARM PIN	
30	S46903001	1	アタマツキトメネジ4X5	SET SCREW, M4X5	
31	S23341009	1	チヨウセツネジツマミナツト	NUT	
45	S23349001	1	レバーチヨウセツイタ	LEVER ADJUSTING PLATE	
46	060400812	2	バインドM4X8	SCREW, BIND M4X8	
47	011502012	2	トメネジ5X20ヒラ	SET SCREW, (FT) M5X20	
48	021500312	2	3シユナツト5	NUT, 3 M5	
53	S46841001	1	ウウオクリアゲリンク	LINK	
54	S46842001	1	ダンネジ4	SHOULDER SCREW, M4	
55	158722002	2	ザガネ4.2	WASHER, PLAIN 4.2	
56	S46843001	1	カラー	COLLAR	
57	062401612	1	ナベコM4X16	SCREW, PAN M4X16	
5	S46889001	1	<V71A> シユオサエウデ	MAIN PRESSER ARM	
34	S37070121	1	フィンガーガードV	FINGER GUARD, V	
35	060300412	1	バインドM3X4	SCREW, BIND M3X4	
5	S46908001	1	<V72A> シユオサエウデ	MAIN PRESSER ARM	
36	S20298001	1	ナカオサエウデ	PRESSER ARM	
37	062350612	2	ナベコM3.5X6	SCREW, PAN M3.5X6	
44	S23364000	1	<テープ付け用> テープアンナイ	<FOR TAPING> TAPE GUIDE	

D. 押工関係 / Presser foot mechanism

V71A  
3020

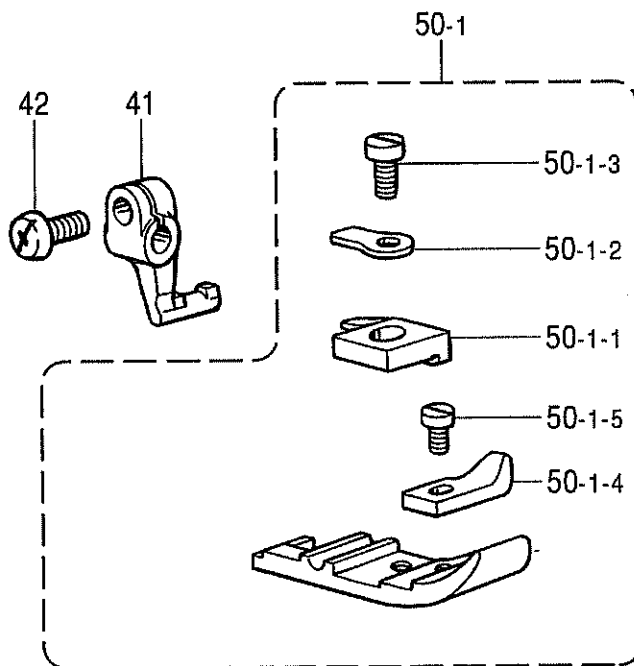

V72A  
3020  
3060  
3420  
3620

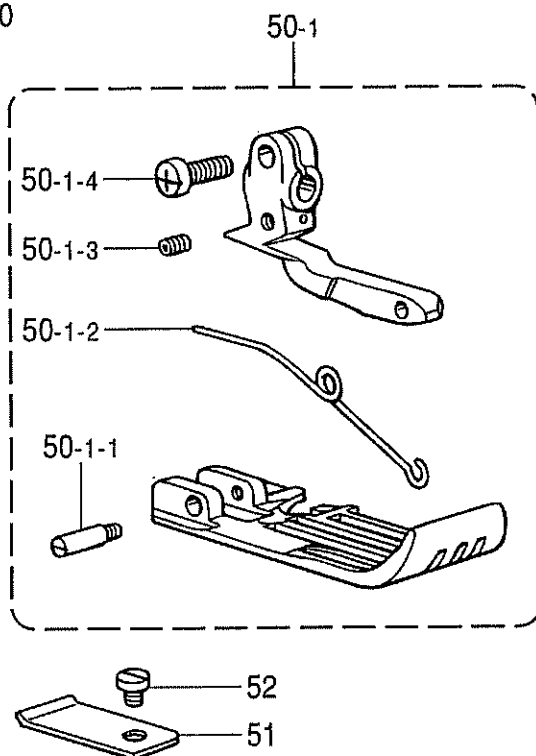

V72A  
3021 (小回り用 / FOR SMALL TYPE)

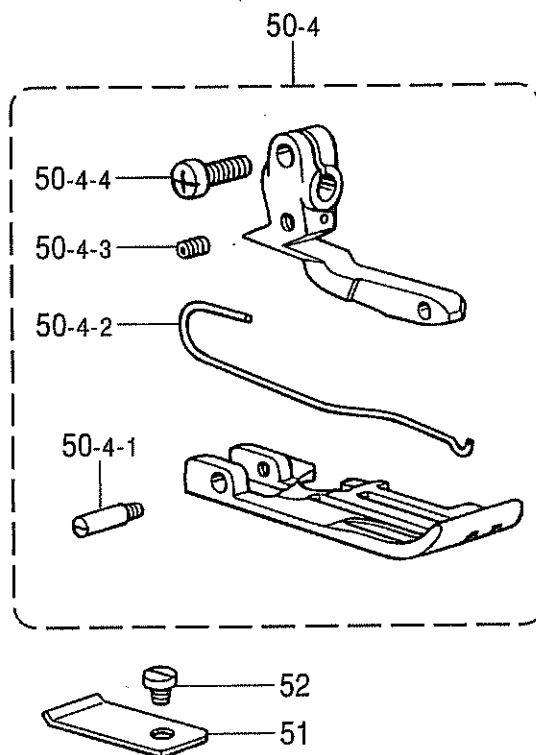



D. 押工関係 / Presser foot mechanism

REF.NO.	CODE	Q'TY	ヒンメイ	NAME OF PARTS	RM
50-1	※	1	V71A <3020> オサエクミ	PRESSER FOOT ASSY	
50-1-1	※	1	ツメ	STITCH TONGUE	
50-1-2	S19496001	1	オサエトリツケイタ	PRESSER FOOT PLATE	
50-1-3	150755001	1	シメネジ3.18	SCREW, SM3.18	
50-1-4	S19279001	1	オサエF	PRESSER FOOT, F	
50-1-5	060630412	1	バインド238-56X4	SCREW, BIND SM2.38-56X4	
41	S20494001	1	フクオサエウデ	SUB PRESSER ARM	
42	062670712	1	ナベコ357-40X7	SCREW, PAN SM3.57-40X7	
50-1	※	1	V72A <3020,3060,3420,3620> オサエクミ	PRESSWE FOOT ASSY	
50-1-1	S19346001	1	シテンネジ	SCREW	
50-1-2	S20842001	1	オサエネジリバネ	TWIST SPRING	
50-1-3	148294001	1	アナトメネジ3.57クボミ	SET SCREW, SOCKET (CP) SM3.57	
50-1-4	062670712	1	ナベコ357-40X7	SCREW, PAN SM3.57-40X7	
51	S19535001	1	オサエBホジヨイタ	PRESSER FOOT (B) SUPPORT PLATE	
52	140530002	1	シメネジ2.38	SCREW, SM2.38	
50-4	※	1	V72A <3021 小回り用> オサエクミ	<3021 FOR SMALL TYPE> PRESSWE FOOT ASSY	
50-4-1	S19346001	1	シテンネジ	SCREW	
50-4-2	S25083001	1	オサエネジリバネ	TWIST SPRING	
50-4-3	148294001	1	アナトメネジ3.57クボミ	SET SCREW, SOCKET (CP) SM3.57	
50-4-4	062670712	1	ナベコ357-40X7	SCREW, PAN SM3.57-40X7	
51	S19535001	1	オサエBホジヨイタ	PRESSER FOOT (B) SUPPORT PLATE	
52	140530002	1	シメネジ2.38	SCREW, SM2.38	

E. 送り関係 / Feed mechanism

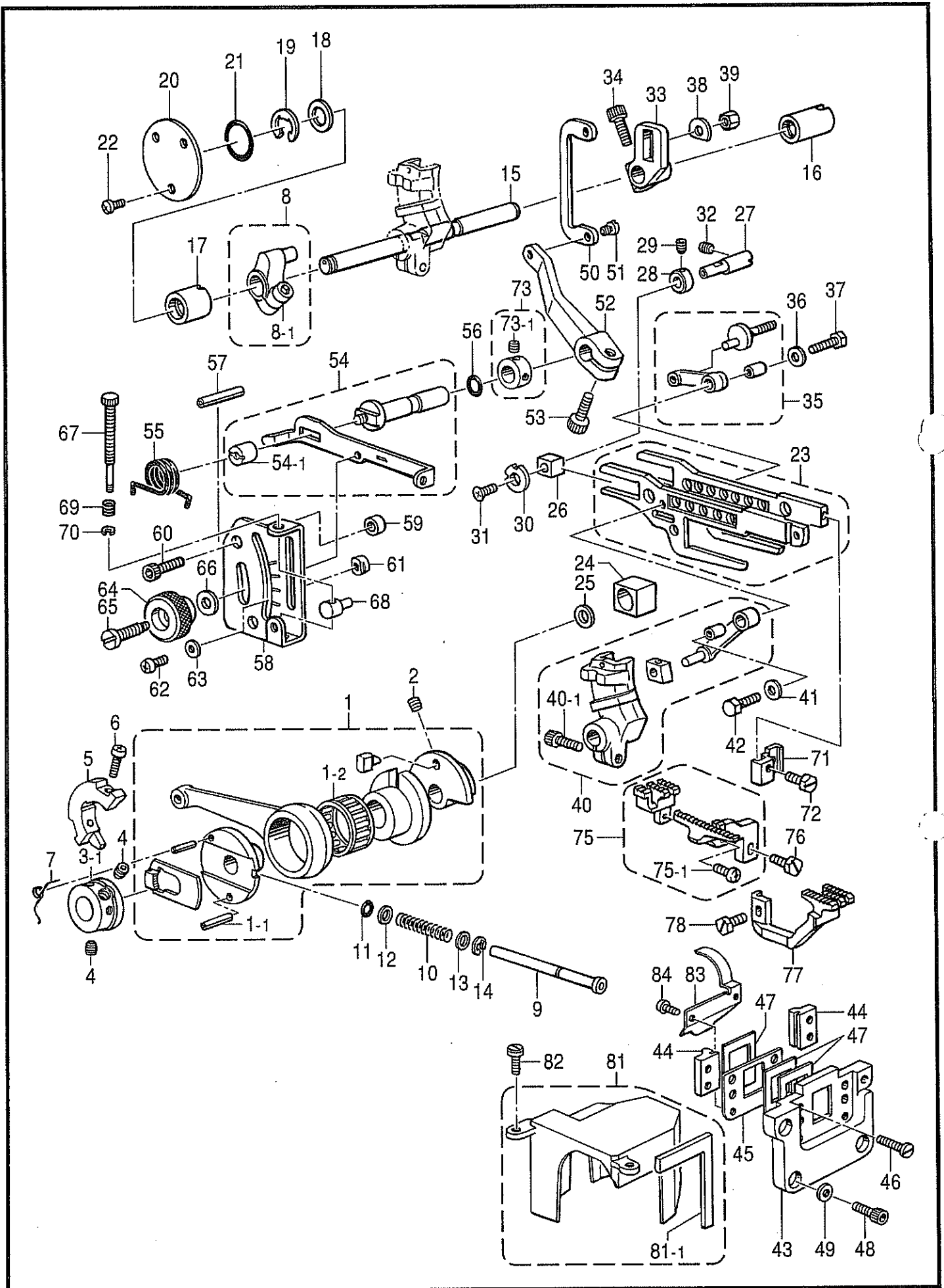

## E. 送り関係 / Feed mechanism

REF.NO.	CODE	Q'TY	ヒンメイ	NAME OF PARTS	RM
1	S20496101	1	ヘンシンリンクミ	ECCENTRIC LINK ASSY	
1-1	047250842	1	スプリングピンAW2.5	PIN, SPRING ROLL AW2.5	
1-2	S20500001	1	ニードルジクウケ24 (赤)	NEEDLE BEARING 24 RED	
1-2	S20500002	1	ニードルジクウケ24 (青)	NEEDLE BEARING 24 BLUE	
1-2	S20500003	1	ニードルジクウケ24 (白)	NEEDLE BEARING 24 WHITE	
2	012060632	2	アナヒラ6X6	SET SCREW, SOCKET (FT) M6X6	
3-1	S20507001	1	ラチエツト	RATCHET	
4	012060632	2	アナヒラ6X6	SET SCREW, SOCKET (FT) M6X6	
5	S23615001	1	バランスウエイト	BALANCE WEIGHT	
6	062401012	2	ナベコM4X10	SCREW, PAN M4X10	
7	S23458101	1	ラチエツトメネジリバネ	SPRING, TWIST	
8	S39589021	1	オクリウデクミ	FEED ARM ASSY	
8-1	018061632	1	アナボルト6X16	BOLT, SOCKET M6X16	
9	S39674001	1	オクリチヨウセツボタンジク	FEED ADJUST SHAFT	
10	S39675001	1	ボタンジクバネ	SPRING	
11	081005070	1	OリングP5	O RING, P5	
12	025710232	1	ヒラザガネネチユウ4.76	WASHER, PLAIN M 4.76	
13	025710232	1	ヒラザガネネチユウ4.76	WASHER, PLAIN M 4.76	
14	048040342	1	トメワE4	RETAINING RING, E4	
15	S39676121	1	オクリジク	FEED SHAFT	
16	S39677021	1	メタル11.11-17	BUSH, 11.11-17	
17	S39678021	1	オクリジクメタルL	FEED SHAFT BUSH, L	
18	S30562000	1	ザガネ	WASHER	
19	048090342	1	トメワE9	RETAINING RING, E9	
20	S39679001	1	オクリジクメタルLフタ	FEED SHAFT BUSH CAP, L	
21	081020070	1	OリングP20	O RING, P20	
22	060400612	3	バインドM4X6	SCREW, BIND M4X6	
23	S46891001	1	オクリダイクミ	FEED BAR ASSY	
24	S38312050	1	ジヨウゲオクリカクゴマ	FEED LIFTING SLIDE BLOCK	
25	142628001	2	スイハイオクリ克蘭クリング	FEED ROCK CRANK RING	
26	S39683000	1	オクリダイカクゴマ	FEED BAR SLIDE BLOCK	
27	S39684021	1	オクリダイカクコマジク	FEED BAR SLIDE BLOCK SHAFT	
28	S39685001	1	セツトカラー	SET SCREW COLLAR	
29	012400432	1	アナヒラ4X4	SET SCREW, SOCKET (FT) M4X4	
30	S20530001	1	ザガネ	WASHER	
31	004350812	1	+サヲコ35X8	SCREW, FLAT M3.5X8	
32	012400832	1	アナヒラ4X8	SET SCREW, SOCKET (FT) M4X8	
33	S42042021	1	シユオクリウデ	MAIN FEED ARM	
34	018061632	1	アナボルト6X16	BOLT, SOCKET M6X16	
35	S39773001	1	シユオクリリンククミ	MAIN FEED LINK ASSY	
36	S39690021	1	ザガネ	WASHER	
37	S23360001	1	ボルト5X15	BOLT, M5X15	
38	S02573000	1	ザガネ	WASHER	
39	S39691001	1	ナツト5	NUT, M5	
40	S39769051	1	サドウオクリウデリンククミ	DIFF. FEED ARM LINK ASSY	
40-1	018061632	1	アナボルト6X16	BOLT, SOCKET M6X16	
41	S39690021	1	ザガネ	WASHER	
42	S23360001	1	ボルト5X15	BOLT, M5X15	
43	S20523000	1	オクリダイアンナイササエ	FEED BAR GUIDE SUPPORT	
44	S20524000	2	オクリダイアンナイ	FEED BAR GUIDE	
45	S20525001	1	ボウジンイタササエ	FRAGMENT PROTECTOR PLATE	
46	S20740101	4	シメネジ4X10シール	SCREW, SEAL M4X10	
47	S20526000	3	ボウジンイタ	FRAGMENT PROTECTOR PLATE	
48	S43916001	4	アナボルト4X8シール	SCREW, SEAL M4X10	
49	025040132	4	ヒラザガネシヨウ4	WASHER, PLAIN S 4	
50	S39692021	1	サドウチヨウセツリンク	DIFFERENTIAL FEED ADJUST LINK	
51	S20543101	1	シメネジ5	SCREW, M5	
52	S20544000	1	サドウリンクレバー	DIFFERENTIAL LINK LEVER	
53	018061432	1	アナボルト6X14	BOLT, SOCKET M6X14	

E. 送り関係 / Feed mechanism

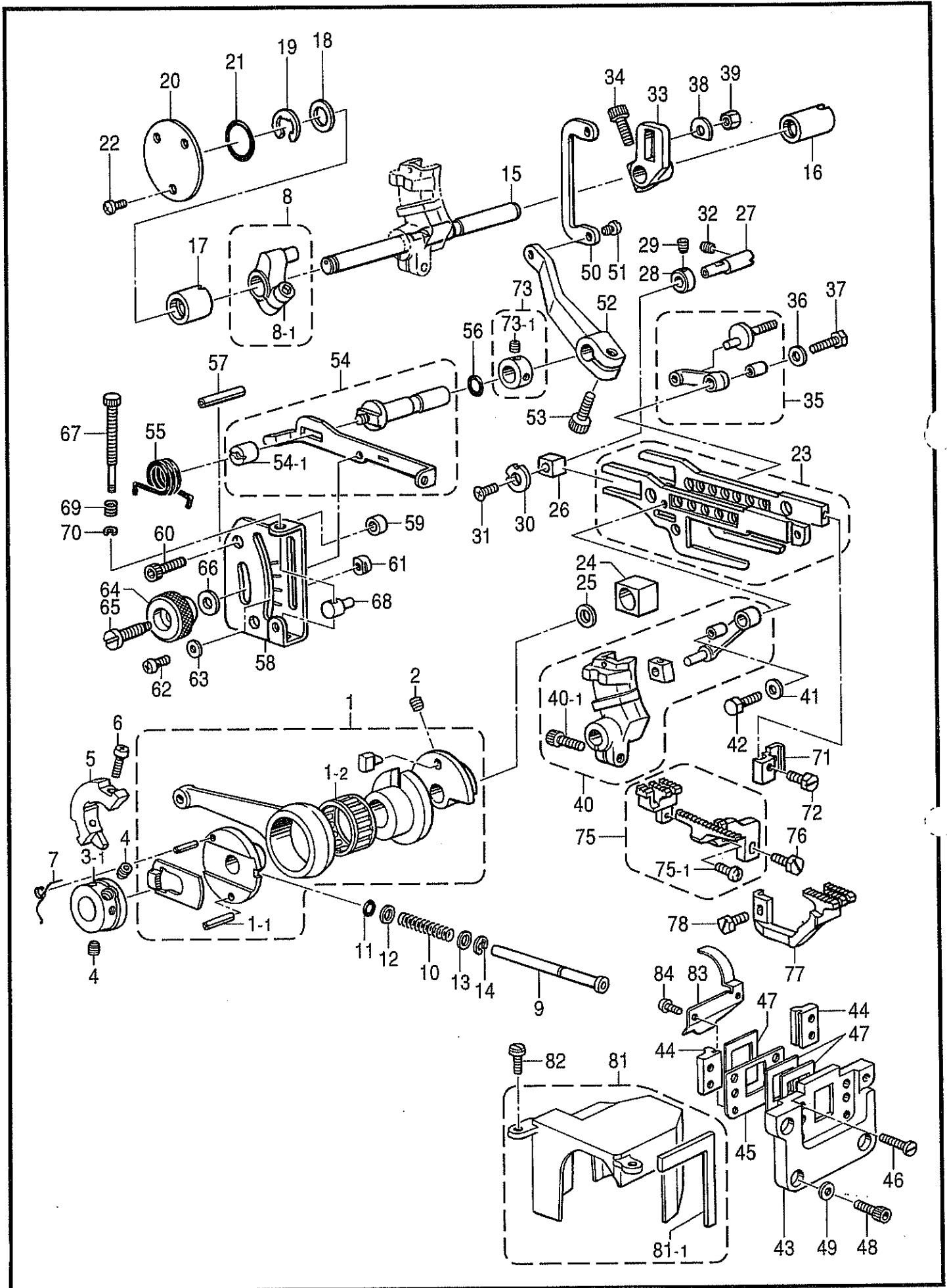

## E. 送り関係 / Feed mechanism

REF.NO.	CODE	Q'TY	ヒンメイ	NAME OF PARTS	RM
54	S39593021	1	サドウチヨウセツレバークミ	DIFF. FEED ADJUST LEVER ASSY	
54-1	S39596021	1	マルナツト6	NUT, ROUND M6	
55	S20547001	1	レバーバネ	SPRING	
56	081005670	1	OリングPW5	O RING, PW5	
57	047502542	1	スプリングピンAW5	PIN, SPRING ROLL AW5	
58	S20554001	1	サドウリヨウメモリアタ	DIFFERENTIAL STITCH CONTROL PLATE	
59	S20548001	2	カラー	COLLAR	
60	018061632	2	アナボルト6X16	BOLT, SOCKET M6X16	
61	S25818051	2	チヨウセツレバーストツバ	STOPPER FOR ADJUST LEVER	
62	060350812	2	バインド35X8	SCREW, BIND M3.5X8	
63	025350332	2	ヒラザガネダイ3.5	WASHER, PLAIN L 3.5	
64	S39694021	1	セツトネジツマミ	SET SCREW KNOB	
65	S39695001	1	セツトネジ	SET SCREW	
66	S20560001	1	サラバネザガネ	SPRING WASHER	
67	S20561001	1	マイクロチヨウセツネジ	MICRO ADJUST SCREW	
68	S46895001	1	マイクロチヨウセツストツハ	STOPPER, MICRO ADJUST.	
69	S29094001	1	マイクロチヨウセツネジバネ	MICRO ADJUST SPRING	
70	048040342	1	トメワE4	RETAINING RING, E4	
71	S23628051	1	シユオクリバトリツケダイ	FEED DOG SETTING BASE	
72	S23621101	1	ボルト35X8	BOLT, M3.5X8	
73	S23612051	1	セツトカラークミ	SET SCREW COLLAR ASSY	
73-1	012060632	2	アナヒラ6X6	SET SCREW, SOCKET (FT) M6X6	
75	※	1	シユオクリバクミ	MAIN FEED DOG ASSY	
75-1	060630712	1	バインド238-56X7	SCREW, BIND SM2.38-56X7	
76	S23621101	1	ボルト35X8	BOLT, M3.5X8	
77	※	1	サドウオクリバ	DIFFERENTIAL FEED DOG	
78	S23621101	1	ボルト35X8	BOLT, M3.5X8	
81	S21091000	1	ヘンシンリンカバークミ	ECCENTRIC WHEEL COVER ASSY	
81-1	S21092000	1	カバースポンジ	COVER SPONGE	
82	S23616101	2	シメネジ4X10	SCREW, M4X10	
83	S20527001	1	アブラキリイタ	OIL REJECTOR PLATE	
84	S23453001	2	ナベコ3X5シール	SCREW 3X5 SEAL	

F. 上送り関係 / Upper feed mechanism

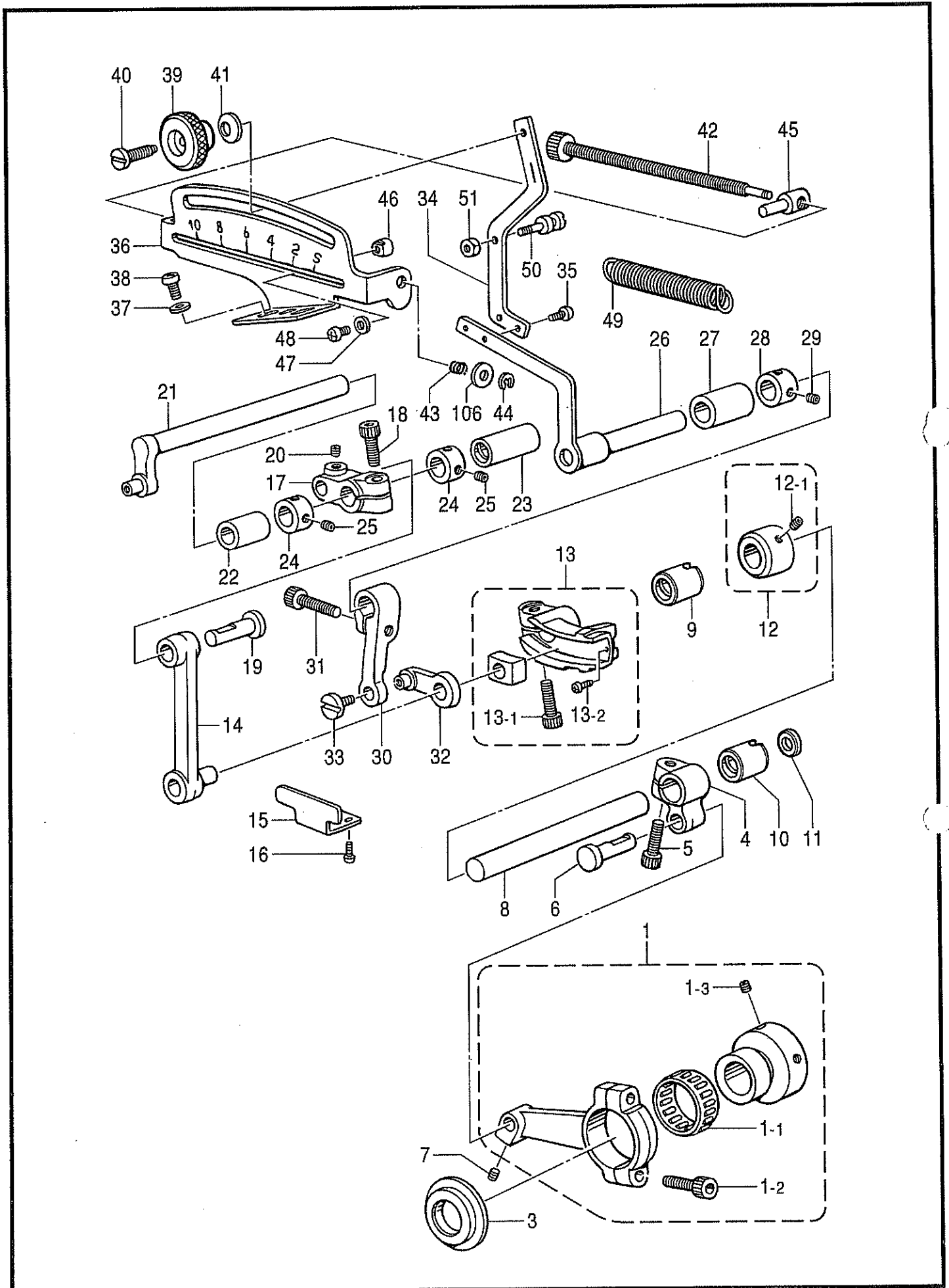

F. 上送り関係 / Upper feed mechanism

REF.NO.	CODE	Q'TY	ヒンメイ	NAME OF PARTS	RM
1	S20139101	1	スイヘイオクリヘンシンリンクミ	ECCENTRIC WHEEL ASSY, W/SCREW	
1-1	S20500001	1	ニードルジクウケ24 (赤)	NEEDLE BEARING, 24 RED	
1-1	S20500002	1	ニードルジクウケ24 (青)	NEEDLE BEARING, 24 BLUE	
1-1	S20500003	1	ニードルジクウケ24 (白)	NEEDLE BEARING, 24 WHITE	
1-2	018401622	2	アナボルト4X16	BOLT, SOCKET M4X16	
1-3	012060632	2	アナヒラ6X6	SET SCREW, SOCKET (FT) M6X6	
3	S20144000	1	オクリロツドササエ	FEED ROD SUPPORT	
4	S20145001	1	オクリウデ	FEED ARM	
5	S20175101	1	アナホルト6X16ホソメ	BOLT, SOCKET M6X16	
6	146532001	1	オクリロツドピン	PIN	
7	012060632	1	アナヒラ6X6	SET SCREW, SOCKET (FT) M6X6	
8	S20146001	1	オクリジク	FEED SHAFT	
9	S39728021	1	メタル11.11-18	BUSH, 11.11-18	
10	S39677021	1	メタル11.11-17	BUSH, 11.11-17	
11	S28044009	1	ゴムセン20.8	RUBBER CAP, 20.8	
12	S23619001	1	セツトカラークミ	SET SCREW COLLAR ASSY	
12-1	012060632	2	アナヒラ6X6	SET SCREW, SOCKET (FT) M6X6	
13	S20147001	1	スイヘイチヨウセツウテコマクミ	L-FEED ADJUST. ARM BLOCK ASSY	
13-1	S20175101	1	アナホルト6X16ホソメ	BOLT, SOCKET M6X16	
13-2	S20158101	2	ナベコ25X3	SCREW, PAN M2.5X3	
14	S20152001	1	スイヘイオクリリンク	FEED ROCK LINK	
15	S20151001	1	スイヘイオクリリンクオサエ	FEED ROCK LINK SUPPORT	
16	062300512	2	ナベコ3X5	SCREW, PAN M3X5	
17	S20153001	1	オクリウデ	FEED ARM	
18	S20175101	1	アナホルト6X16ホソメ	BOLT, SOCKET M6X16	
19	146532001	1	オクリロツドピン	PIN	
20	012060632	1	アナヒラ6X6	SET SCREW, SOCKET (FT) M6X6	
21	S20154001	1	スイヘイクランクジク	LEVEL FEED CRANK SHAFT	
22	S47031000	1	クランクジクメタルL	CRANKSHAFT BUSHING, L	
23	S20156000	1	クランクジクメタルR	CRANKSHAFT BUSH, R	
24	S20197001	2	セツトカラー	SET SCREW COLLAR	
25	012400432	4	アナヒラ4X4	SET SCREW, SOCKET (FT) M4X4	
26	S20157001	1	スイヘイチヨウセツレバジク	L-FEED ADJUSTING LEVER SHAFT	
27	S20546001	1	チヨウセツレバーメタル	BUSHING, FEED ADJUSTING LEVER	
28	S20197001	1	セツトカラー	SET SCREW COLLAR	
29	012400432	2	アナヒラ4X4	SET SCREW, SOCKET (FT) M4X4	
30	S20159001	1	スイヘイチヨウセツレバー	LEVEL FEED ADJUSTING LEVER	
31	018061632	1	アナボルト6X16	BOLT, SOCKET M6X16	
32	S20160001	1	オクリチヨウセツリンク	FEED ADJUSTING LINK	
33	S20189001	1	シメネジ3.5	SCREW, M3.5	
34	S20161101	1	オクリチヨウセツイタ	FEED ADJUSTING PLATE	
35	062350612	2	ナベコM3.5X6	SCREW, PAN M3.5X6	
36	S20162001	1	スイヘイメモリアタ	L-FEED LENGTH CONTROL PLATE	
37	025060236	2	ヒラザガネチユウ6	WASHER, PLAIN M 6	
38	062061012	2	ナベコ6X10	SCREW, PAN M6X10	
39	S39694021	1	セツトネジツマミ	KNOB, SCREW	
40	S39695001	1	セツトネジ	SET SCREW	
41	S20560001	1	サラバネザガネ	WASHER, FLAT SPRING	
42	S20163001	1	マイクロチヨウセツネジ	MICRO ADJUSTING SCREW	
43	S29132001	1	マイクロチヨウセツバネ	SPRING, MICRO ADJUSTING	
44	048040342	1	トメワE4	RETAINING RING, E4	
45	S20165001	1	マイクロチヨウセツストツバ	MICRO ADJUST STOPPER	
46	S25818051	1	チヨウセツレバーストツバ	STOPPER, ADJUSTING LEVER	
47	105161004	1	ザガネ	WASHER	
48	062350612	1	ナベコM3.5X6	SCREW, PAN M3.5X6	
49	151951001	1	クドーレバーヒキバネ	SPRING	
50	S20184101	1	バネカケ	SPRING HOOK	
51	021350106	1	1シユナツト35	NUT, 1 M3.5	
106	025710132	1	ヒラザガネシヨウ4.76	WASHER, PLAIN S 4.76	

F. 上送り関係 / Upper feed mechanism

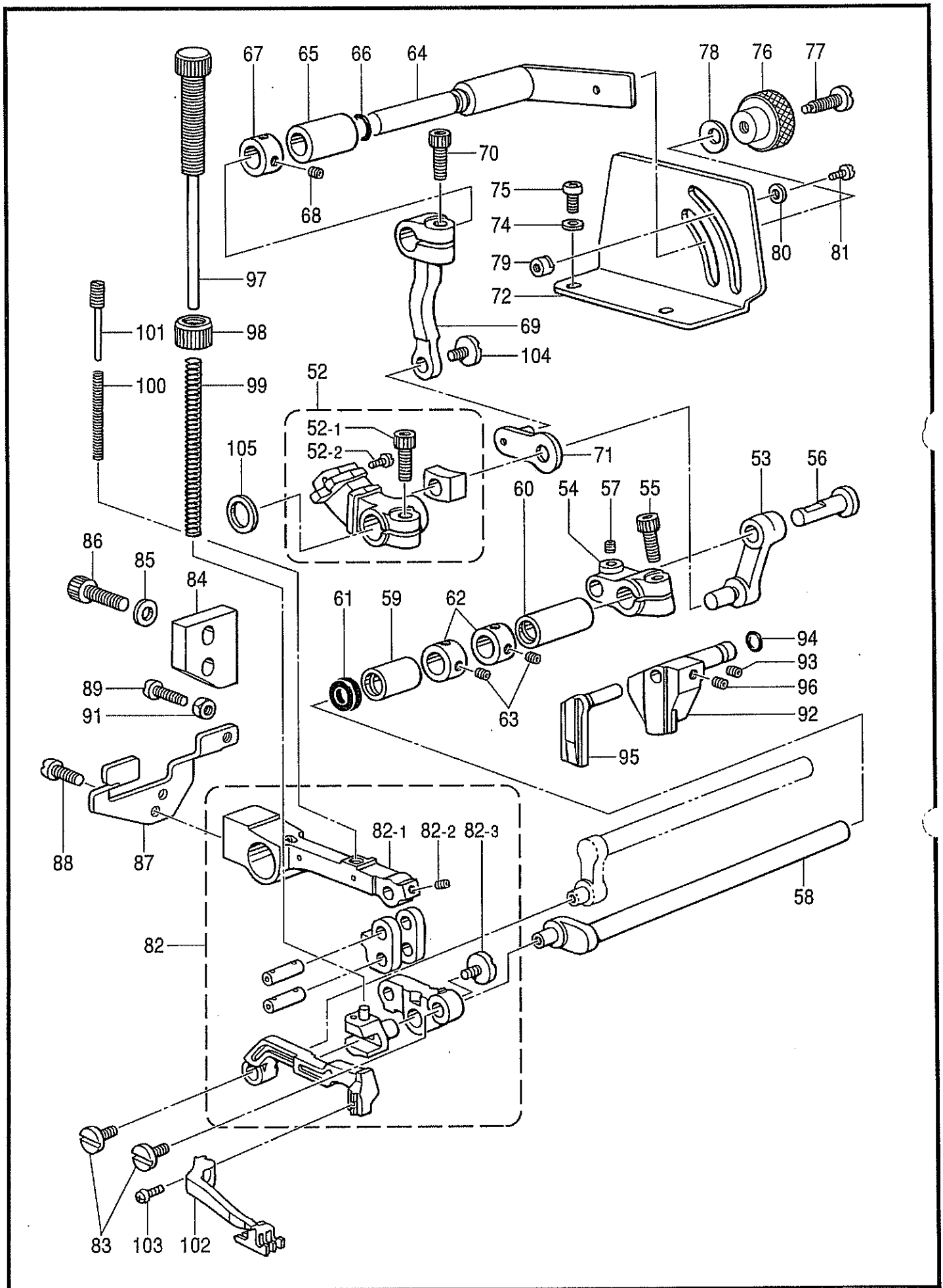



## F. 上送り関係 / Upper feed mechanism

REF.NO.	CODE	Q'TY	ヒンメイ	NAME OF PARTS	RM
52	S20168001	1	チヨウセツウデコマクミ	V-FEED ADJUST. ARM BLOCK ASSY	
52-1	S20175101	1	アナホルト6X16ホソメ	BOLT, SOCKET M6X16	
52-2	S20158101	2	ナベコ25X3	SCREW, PAN M2.5X3	
53	S20172001	1	ジヨウゲオクリリンク	FEED LIFTING LINK	
54	S20153001	1	オクリウデ	FEED ARM	
55	S20175101	1	アナホルト6X16ホソメ	BOLT, SOCKET M6X16	
56	146532001	1	オクリロツドピン	PIN	
57	012060632	1	アナヒラ6X6	SET SCREW, SOCKET (FT) M6X6	
58	S20174001	1	ジヨウゲクランクジク	FEED LIFTING CRANK SHAFT	
59	S20155000	1	クランクジクメタルL	CRANKSHAFT BUSH, L	
60	S20156000	1	クランクジクメタルR	CRANKSHAFT BUSH, R	
61	155539000	1	ダストシール	DUST SEAL	
62	S20197001	2	セツトカラー	SET SCREW COLLAR	
63	012400432	4	アナヒラ4X4	SET SCREW, SOCKET (FT) M4X4	
64	S20176001	1	ULチヨウセツレバージク	ADJUSTING LEVER SHAFT, UL	
65	S20546001	1	チヨウセツレバーメタル	BUSHING, FEED ADJUSTING LEVER	
66	081005670	1	リングPW5	O RING, PW5	
67	S20197001	1	セツトカラー	SET SCREW COLLAR	
68	012400432	2	アナヒラ4X4	SET SCREW, SOCKET (FT) M4X4	
69	S20177001	1	ジヨウゲチヨウセツレバー	VERTICAL FEED ADJUSTING LEVER	
70	018061632	1	アナボルト6X16	BOLT, SOCKET M6X16	
71	S20160001	1	オクリチヨウセツリンク	FEED ADJUSTING LINK	
72	S20179001	1	ジヨウゲメモリアタ	V-FEED LENGTH CONTROL PLATE	
74	102707002	2	ザガネ	WASHER, PLAIN 4	
75	060400812	2	バインドM4X8	SCREW, BIND M4X8	
76	S39694021	1	セツトネジツマミ	KNOB, SCREW	
77	S39695001	1	セツトネジ	SET SCREW	
78	S20560001	1	サラバネザガネ	WASHER, FLAT SPRING	
79	S25818051	2	チヨウセツレバーストツバ	STOPPER, ADJUSTING LEVER	
80	105161004	2	ザガネ	WASHER	
81	062350612	2	ナベコM3.5X6	SCREW, PAN M3.5X6	
82	S20181001	1	ウワオクリダイクミ	UPPER FEED BRACKET ASSY	
82-1	S20182001	1	ウワオクリササエダイ	UPPER FEED SUPPORT BAR	
82-2	012400432	2	アナヒラ4X4	SET SCREW, SOCKET (FT) M4X4	
82-3	S20191001	1	シメネジ4	SCREW, M4	
83	S20189001	2	シメネジ3.5	SCREW, M3.5	
84	S20183001	1	ウワオクリクツシヨンドダイ	UPPER FEED CUSHION BRACKET	
85	025060236	2	ヒラザガネチユウ6	WASHER, PLAIN M 6	
86	018061632	2	アナボルト6X16	BOLT, SOCKET M6X16	
87	S46844001	1	ウワオクリアゲ	UPPER FEED LIFTER	
88	062501212	2	ナベコ5X12	SCREW, PAN M5X12	
89	060401412	1	バインドM4X14	SCREW, BIND M4X14	
91	021400202	1	2シユナツト4	NUT, 2 M4	
92	S20193001	1	ウワオクリダイアンナイR	UPPER FEED BAR GUIDE, R	
93	012060632	1	アナヒラ6X6	SET SCREW, SOCKET (FT) M6X6	
94	081005070	1	リングP5	O RING, P5	
95	S20194001	1	ウワオクリダイアンナイL	UPPER FEED BAR GUIDE, L	
96	012400632	1	アナヒラ4X6	SET SCREW, SOCKET (FT) M4X6	
97	S20195001	1	オサエチヨウセツネジ	ADJUSTING SCREW	
98	S23341009	1	チヨウセツネジツマミナツト	NUT	
99	S00204001	1	ウエオクリオサエバネ	SPRING	
100	S20202001	1	ウワオクリササエダイバネ	SPRING	
101	S20201001	1	ササエダイバネアンナイ	SPRING GUIDE	
102	※	1	ウワオクリバ	UPPER FEED DOG	
103	S23621101	1	ボルト35X8	BOLT, M3.5X8	
104	S20189001	1	シメネジ3.5	SCREW, M3.5	
105	S20621001	1	カラー	COLLAR	

G. 上メス・下メス関係 / Knife mechanism

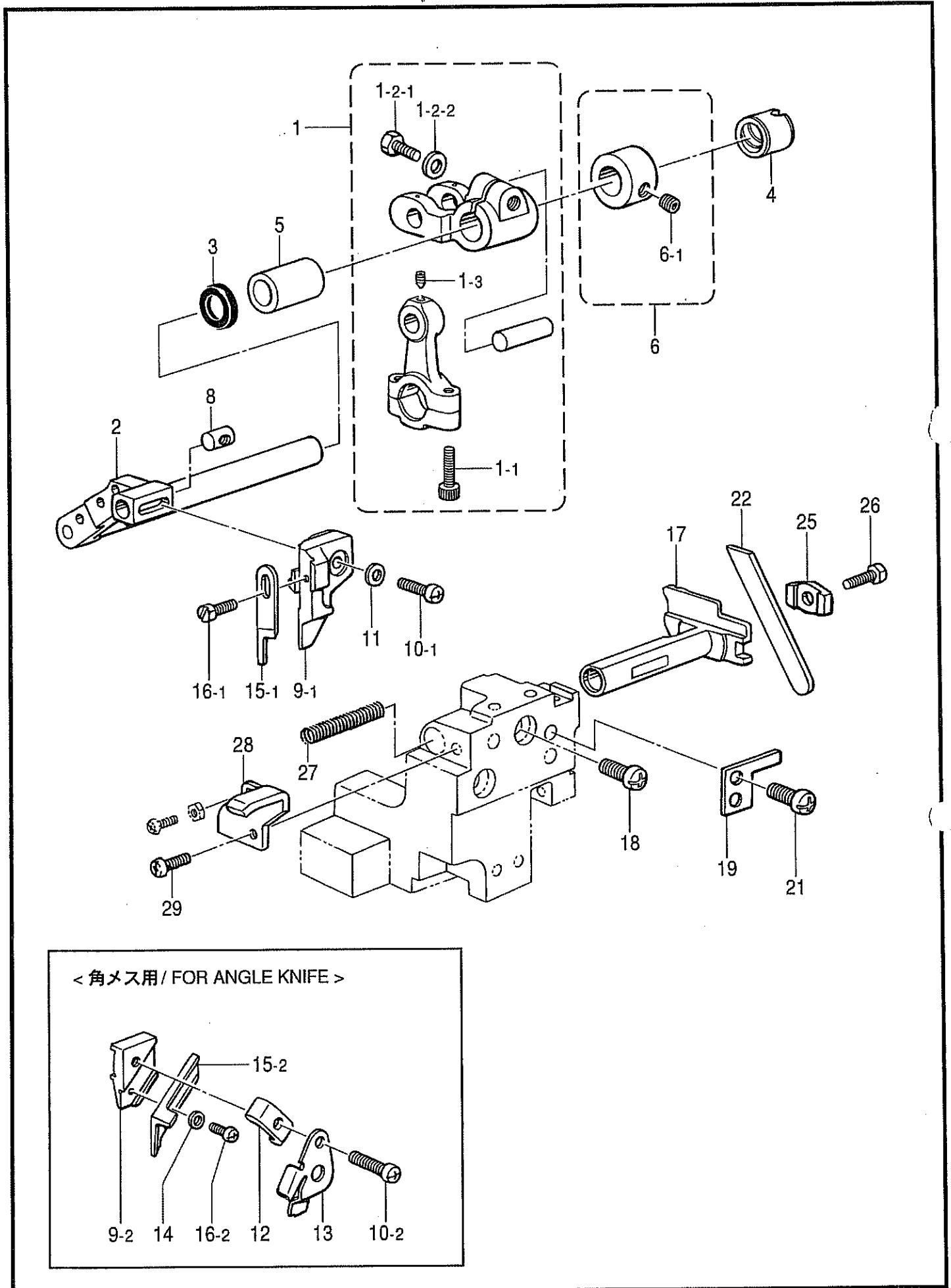

G. 上メス・下メス関係 / Knife mechanism

REF.NO.	CODE	Q'TY	ヒンメイ	NAME OF PARTS	RM
1	S46933001	1	ウワメスクランクロッドクミO	UPPER KNIFE CRANK ROD ASSY, O	
1-1	018401622	2	アナボルト4X16	BOLT, SOCKET M4X16	
1-2-1	017061612	1	ボルト6X16	BOLT, M6X16	
1-2-2	118735002	1	ザガネ	WASHER	
1-3	S23342001	1	アナトガリ4X5	SET SCREW, SOCKET (CN) M4X5	
2	S20571101	1	ウワメスサドウウデ	UPPER KNIFE DIFFERENTIAL ARM	
3	155247000	1	ダストシール	DUST SEAL	
4	S39704021	1	ウワメスメタルL	UPPER KNIFE BUSH L	
5	S39677021	1	メタル11.11-17	BUSH, 11.11-17	
6	S23619001	1	セツトカラークミ	SET SCREW COLLAR ASSY	
6-1	012060632	2	アナヒラ6X6	SET SCREW, SOCKET (FT) M6X6	
8	S20574001	1	ウワメスダキナツト	NUT	
17	S20580101	1	シタメストリツケダイ	LOWER KNIFE HOLDER	
18	062060812	1	ナベコ6X8	SCREW, PAN M6X8	
19	S39707001	1	シタメストリツケダイアンナイ	LOWER KNIFE HOLDER GUIDE	
21	062060812	2	ナベコ6X8	SCREW, PAN M6X8	
22	※	1	シタメス	LOWER KNIFE	
25	S39708001	1	シタメスオサエ	LOWER KNIFE PRESSER	
26	017500812	1	ボルト5X8	BOLT, M5X8	
27	S20585001	1	シタメストリツケダイバネ	SPRING	
28	S39709021	1	シタメスバネウケ	SPRING HOLDER	
29	060400812	1	バインドM4X8	SCREW, BIND M4X8	
<平メス用部品>					<FOR PLAIN KNIFE>
9-1	S20575001	1	ウワメスダキ	UPPER KNIFE HOLDER	
10-1	062401212	1	ナベコ4X12	SCREW, PAN M4X12	
11	025040132	1	ヒラザガネシヨウ4	WASHER, PLAIN S 4	
15-1	144074350	1	ウワメス	UPPER KNIFE	
16-1	S23621101	1	ボルト35X8	BOLT, M3.5X8	
<角メス用部品>					<FOR ANGLE KNIFE>
9-2	S20576001	1	ウワメスダキ	UPPER KNIFE HOLDER	
10-2	062401612	1	ナベコM4X16	SCREW, PAN M4X16	
12	S20577001	1	ウワメスオサエ	UPPER KNIFE PRESSER	
13	S20578101	1	ウワメスオサエイタ	UPPER KNIFE PRESSER PLATE	
14	025030132	1	ヒラザガネシヨウ3	WASHER, PLAIN S 3	
15-2	S20897101	1	カクメス 幅狭 波刃	ANGLE KNIFE, NARROW WAVE EDGE	
16-2	062300412	1	ナベコ3X4	SCREW, PAN M3X4	
<オプションパーツ>					<OPTION PARTS>
15-2	S20896101	1	カクメス 幅狭	ANGLE KNIFE, NARROW	
15-2	S20579101	1	カクメス 幅広	ANGLE KNIFE, WIDE	
15-2	S20898101	1	カクメス 幅広 波刃	ANGLE KNIFE, WIDE WAVE EDGE	

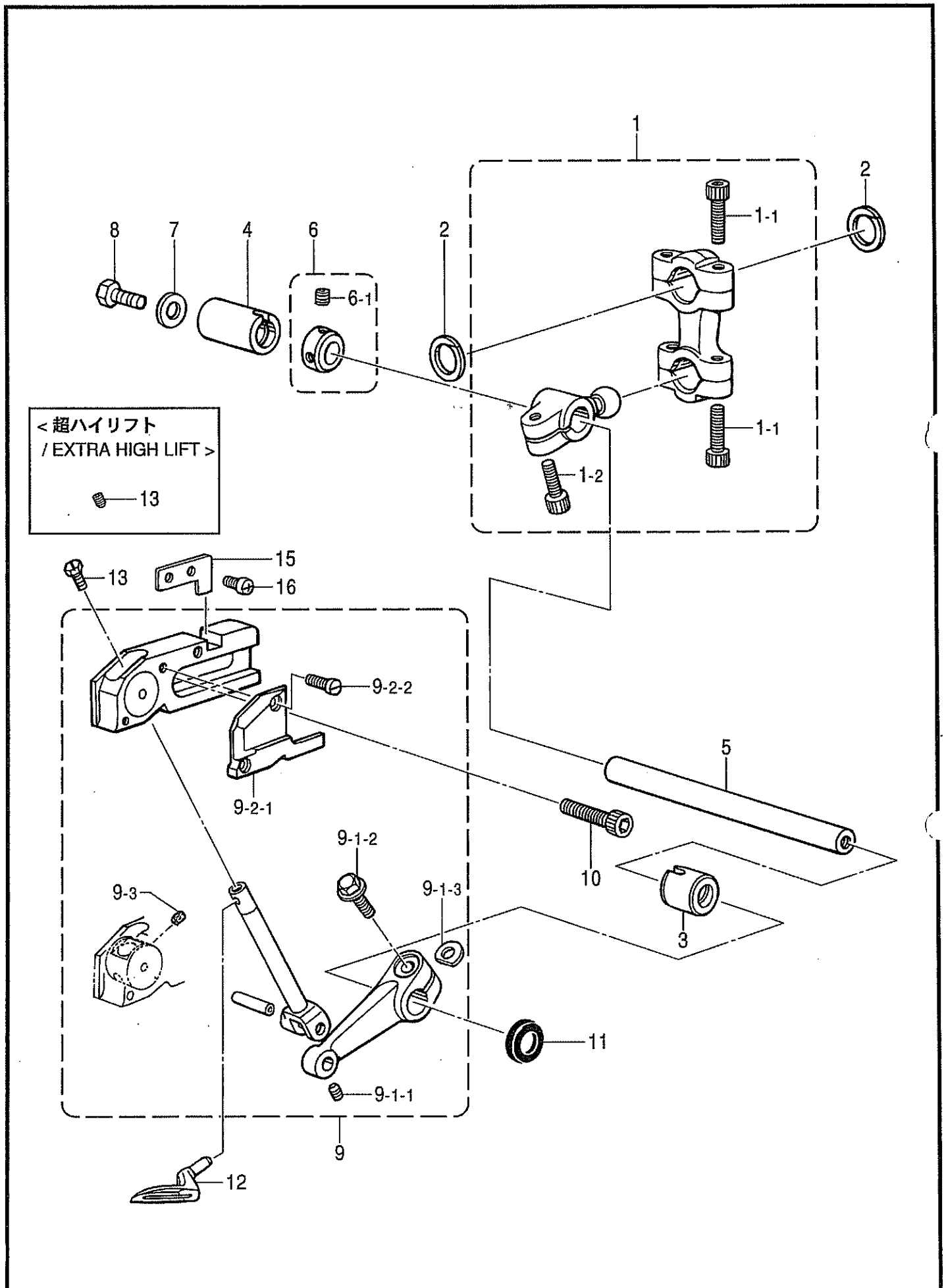

H. 上ルーパ関係 / Over looper mechanism

REF.NO.	CODE	Q'TY	ヒンメイ	NAME OF PARTS	RM
1	S46940001	1	ウワルーパロッドクミHE	OVER LOOPER ROD ASSY, HE	
1-1	018401622	4	アナボルト4X16	BOLT, SOCKET M4X16	
1-2	S23346101	1	アナボルト6X14ホソメ	BOLT, SOCKET M6X14	
2	S20598000	2	ロッドフレドメ	ROD STOPPER	
3	S39728021	1	メタル11.11-18	BUSH, 11.11-18	
4	S39677021	1	メタル11.11-17	BUSH, 11.11-17	
5	S20601001	1	ウワルーパジク	OVER LOOPER SHAFT	
6	S23619001	1	セツトカラークミ	SET SCREW COLLAR ASSY	
6-1	012060632	2	アナヒラ6X6	SET SCREW, SOCKET (FT) M6X6	
7	S23626001	1	ザガネ	WASHER	
8	017060812	1	ボルト6X8	BOLT, M6X8	
<ハイリフト用>				<FOR HIGH LIFT>	
9	S46896001	1	ウワルーパキコウクミSH	OVER LOOPER MECHANISM ASSY, SH	
13	S46903001	1	アタマツキトメネジ4X5	SET SCREW, M4X5	
<超ハイリフト用>				<FOR EXTRA HIGH LIFT>	
9	S46901001	1	ウワルーパキコウクミE	OVER LOOPER MECHANISM ASSY, E	
13	012400432	1	アナヒラ4X4	SET SCREW, SOCKET (FT) M4X4	
9-1-1	S23342001	1	アナトガリ4X5	SET SCREW, SOCKET (CN) M4X5	
9-1-2	S46899001	1	ザガネツキボルト6X16	BOLT, (S/P WASHER) M6X16	
9-1-3	155162001	1	スペーサ	SPACER	
9-2-1	S38320100	1	ウワルーパアンナイオサエ	OVER LOOPER GUIDE HOLDER	
9-2-2	S20355002	2	シメネジ3X8.5	SCREW, M3X8.5	
9-3	S29700000	2	ウワルーパアンナイフェルト	OVER LOOPER GUIDE FELT	
10	018061432	2	アナボルト6X14	BOLT, SOCKET M6X14	
11	155247000	1	ダストシール	DUST SEAL	
12	※	1	ウワルーパ	OVER LOOPER	
15	S23611101	1	アンナイメタルイチギメイタ	POTISIONING PLATE, GUIDE BUSH	
16	060400612	2	バインドM4X6	SCREW, BIND M4X6	

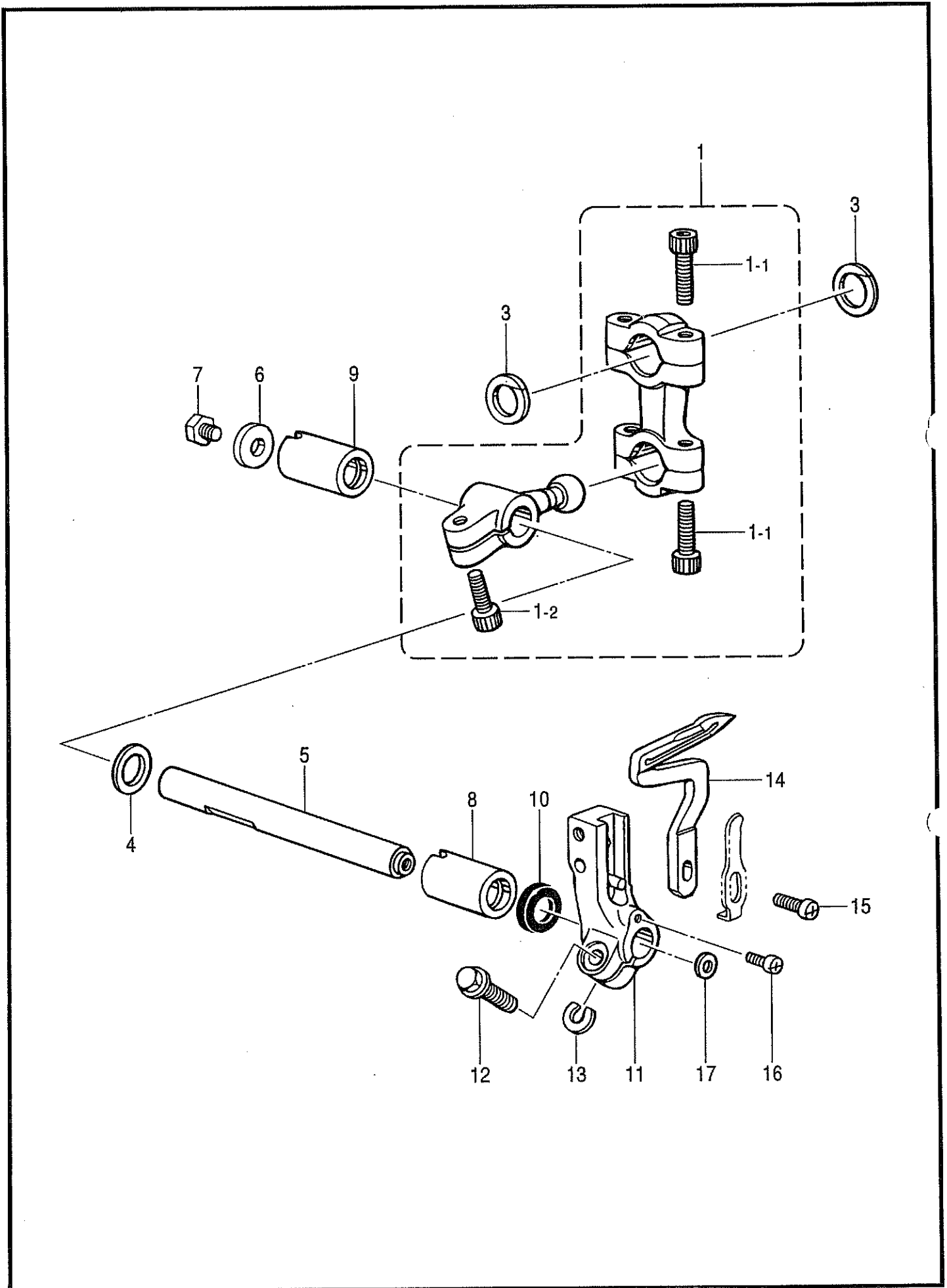

J. 下ルーパ関係 / Under looper mechanism

REF.NO.	CODE	Q'TY	ヒンメイ	NAME OF PARTS	RM
1	S46941001	1	<ハイリフト用> シタルーパロッドクミOSH	<FOR HIGH LIFT> UNDER LOOPER ROD ASSY, O-SH	
1	S46942001	1	<超ハイリフト用> シタルーパロッドクミOE	<FOR EXTRA HIGH LIFT> UNDER LOOPER ROD ASSY, O-E	
1-1	018401622	4	アナボルト4X16	BOLT, SOCKET M4X16	
1-2	S23346101	1	アナボルト6X14ホソメ	BOLT, SOCKET M6X14	
3	S20598000	2	ロッドフレドメ	ROD STOPPER	
4	S20621001	1	カラー	COLLAR	
5	S46904001	1	シタルーパジク	UNDER LOOPER SHAFT	
6	S23626001	1	ザガネ	WASHER	
7	017060812	1	ボルト6X8	BOLT, M6X8	
8	S39728021	1	メタル11.11-18	BUSH, 11.11-18	
9	S39677021	1	メタル11.11-17	BUSH, 11.11-17	
10	155247000	1	ダストシール	DUST SEAL	
11	S20625151	1	シタルーパトリツケダイ	UNDER LOOPER HOLDER	
12	S23614101	1	フランジボルト5X14	BOLT, M5X14	
13	148782001	1	スペーサ	SPACER	
14	S20626001	1	シタルーパ	UNDER LOOPER	
15	060351012	1	バインド3.5X10	SCREW, BIND M3.5X10	
16	060350812	1	バインド3.5X8	SCREW, BIND M3.5X8	
17	158722002	1	ザガネ4.2	WASHER, PLAIN 4.2	

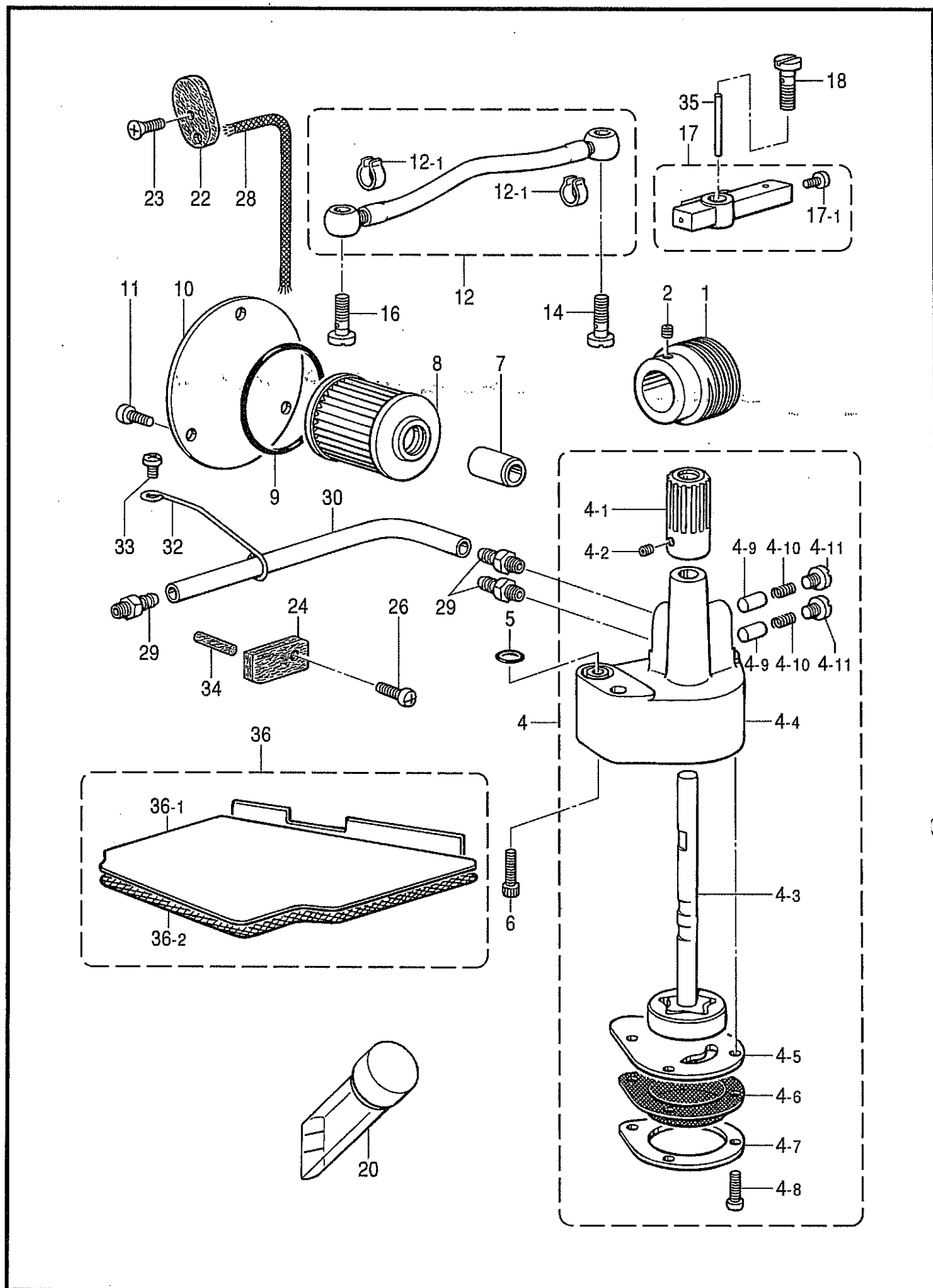



## L. 給油潤滑関係 / Lubrication

REF.NO.	CODE	Q'TY	ヒンメイ	NAME OF PARTS	RM
1	S20655101	1	ウオーム	WORM	
2	012500532	2	アナヒラ5X5	SET SCREW, SOCKET (FT) M5X5	
4	S20300101	1	トロコイドポンプクミ	PUMP ASSY	
4-1	S20657001	1	ウオームホイール	WORM WHEEL	
4-2	012400536	2	アナヒラ4X5	SET SCREW, SOCKET (FT) M4X5	
4-3	S20301001	1	ポンプロータークミ	PUMP INNER ROTER ASSY	
4-4	S20303000	1	ポンプケース	PUMP CASE	
4-5	S20661001	1	ポンプタイフタ	PUMP BODY COVER	
4-6	S20662100	1	ロカモウ	OIL FILTER	
4-7	S20663000	1	ロカモウオサエ	FILTER SUPPORT	
4-8	062351016	4	ナベコ3.5X10	SCREW, PAN M3.5X10	
4-9	144875001	2	プランジャー	PLUNGER	
4-10	144876001	2	プランジャーバネ	SPRING	
4-11	S23460001	2	ナベコ6X5	SCREW, PAN M6X5	
5	081008070	1	OリングP8	O RING, P8	
6	018061432	2	アナボルト6X14	BOLT, SOCKET M6X14	
7	S08957001	1	オイルクチ	OIL FEEDING PIPE	
8	S08956100	1	オイルフィルター	OIL FILTER	
9	081044070	1	OリングP44	O RING, P44	
10	S12987002	1	オイルフィルターフタ	CAP, OIL FILTER	
11	060400812	3	バインドM4X8	SCREW, BIND M4X8	
12	S46905001	1	ビニルチューブクミ	OIL TUBE ASSY	
12-1	147942001	2	ビニルチューブトメガネ	STOP RING	
14	S20199001	1	ハイユパイプツギテ	OIL PIPE JOINT	
16	S20199001	1	ハイユパイプツギテ	OIL PIPE JOINT	
17	S20666001	1	キユウユパイプクミ	OIL PIPE ASSY	
17-1	060400512	1	バインドM4X5	SCREW, BIND M4X5	
18	S20199001	1	ハイユパイプツギテ	OIL PIPE JOINT	
20	148084001	1	オイルゲージマド	OIL GAUGE WINDOW	
22	S20668200	1	ハリボウリンクフェルト	NEEDLE BAR LINK FELT	
23	061400812	1	サラコM4X8	SCREW, FLAT M4X8	
24	S20669000	1	フェルト	FELT	
26	060400812	1	バインドM4X8	SCREW, BIND M4X8	
28	S49337000	1	クミヒモ70	WICK, L = 70	
29	S20180001	3	オイルクチ	OIL FEEDING PIPE	
30	S20200001	1	ビニルチューブ	OIL TUBE, L = 370	
32	S25879001	1	チューブササエ	TUBE SUPPORT	
33	060400812	1	バインドM4X8	SCREW, BIND M4X8	
34	S20392000	1	フェルト	FELT	
35	S25526000	1	ピン	PIN	
36	S43523000	1	フィルタークミ	FILTER ASSY	
36-1	S43522000	1	オイルフィルター	OIL FILTER	
36-2	S43521000	1	ロカモウD	FILTER, D	

L . 給油潤滑關係 / Lubrication

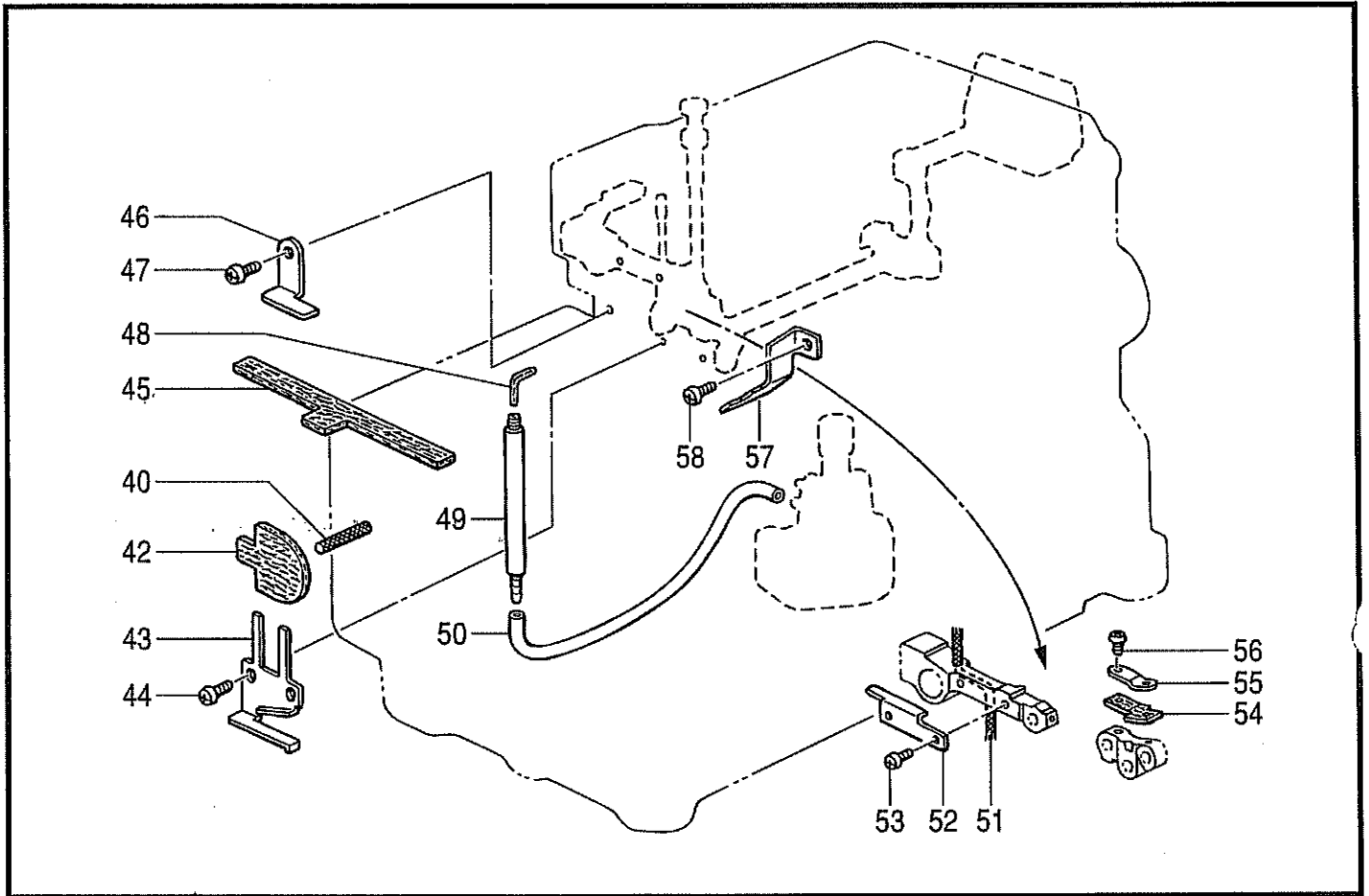

878-V7A,B-350

L. 給油潤滑関係 / Lubrication

REF.NO.	CODE	Q'TY	品名	NAME OF PARTS	RM
40	S20213000	1	クミヒモ	WICK, L= 22	
42	S20214000	1	キユウユフェルト	FELT	
43	S20215001	1	フェルトオサエ	FELT SUPPORT	
44	062400612	2	ナベコM4X6	SCREW, PAN M4X6	
45	S20216000	1	カイシユウフェルト	FELT	
46	S20217001	1	フェルトオサエ	FELT SUPPORT	
47	062400612	1	ナベコM4X6	SCREW, PAN M4X6	
48	147363000	1	フェルト	FELT	
49	S20218001	1	パイプツギテ	PIPE JOINT	
50	S20219001	1	ビニルチューブ	OIL TUBE	
51	S07463000	1	クミヒモ	WICK, L= 70	
52	S20220001	1	オイルヒモアンナイ	WICK GUIDE	
53	S20158101	2	ナベコ25X3	SCREW, PAN M2.5X3	
54	S20221000	1	フェルト	FELT	
55	S20222001	1	フェルトオサエ	FELT SUPPORT	
56	S20158101	2	ナベコ25X3	SCREW, PAN M2.5X3	
57	S20178001	1	ボウジンイタ	FRAGMENT PROTECTOR PLATE	
58	062400612	1	ナベコM4X6	SCREW, PAN M4X6	

878-V7A,B-350

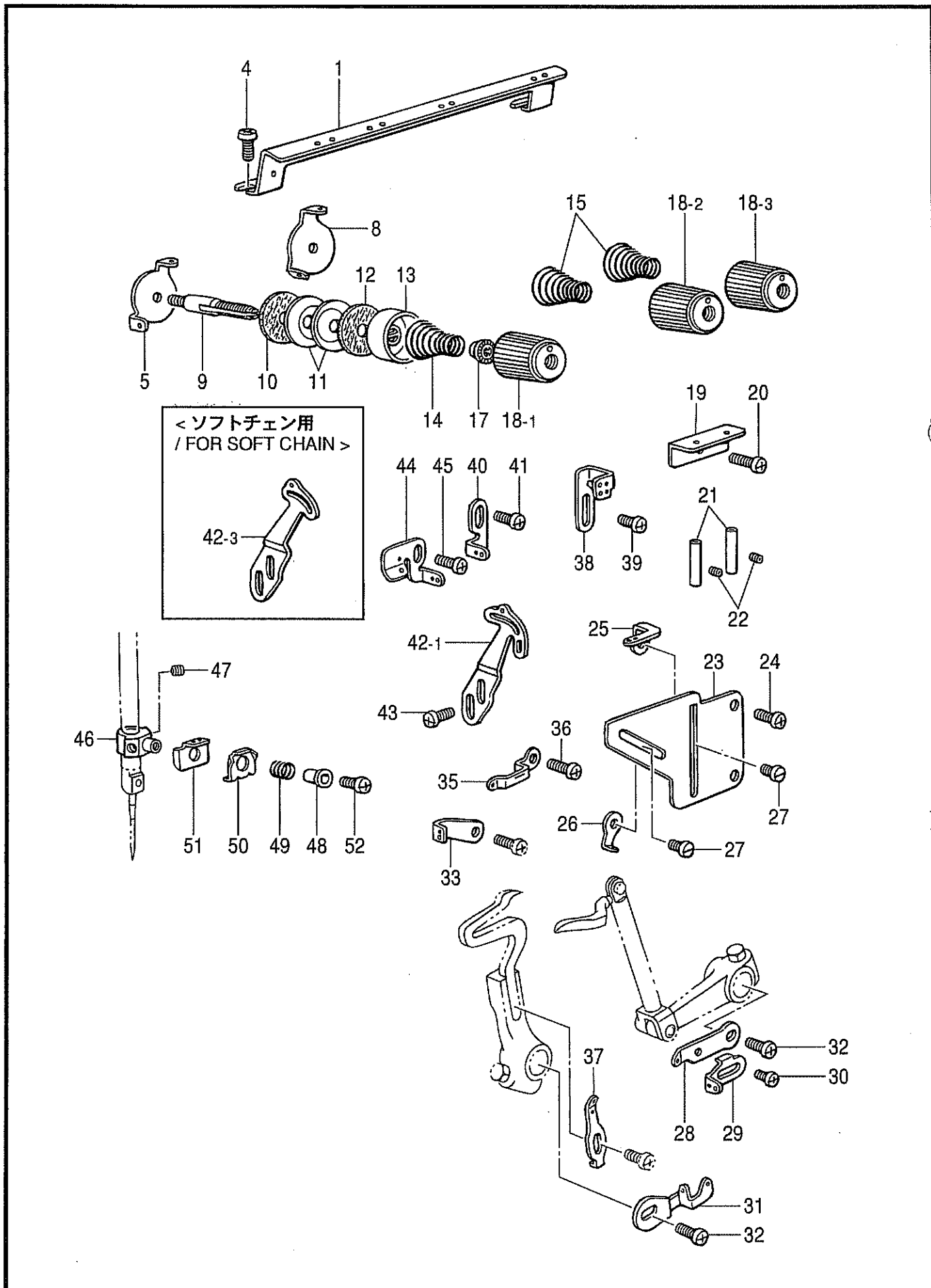

M.糸調子関係 / Thread tension

REF.NO.	CODE	Q'TY	ヒンメイ	NAME OF PARTS	RM
1	S20672001	1	シユイトアンナイ	MAIN THREAD GUIDE	
4	060400812	2	バインドM4X8	SCREW, BIND M4X8	
5	S20674001	1	ハライトアンナイ1N	NEEDLE THREAD GUIDE (1N)	
8	S20675001	2	チヨウシサライトアンナイ	TENSION DISC THREAD GUIDE	
9	S20676051	3	イトチヨウシボウ	TENSION STUD	
10	S20677000	3	イトチヨウシサラフェルト	TENSION DISC FELT	
11	S20673001	6	イトチヨウシサラ	TENSION DISC	
12	110832009	3	イトチヨウシサラフェルト	TENSION DISC FELT	
13	144103009	3	イトチヨウシサラオサエ	TENSION DISC PRESSER	
14	S20678001	1	イトチヨウシバネL	TENSION SPRING, L	
15	S20679001	2	イトチヨウシバネM	TENSION SPRING, M	
17	S20681000	3	チヨウシバネウエザガネ	WASHER	
18-1	S20682103	1	イトチヨウシナツト(赤)	TENSION NUT, RED	
18-2	S20682104	1	イトチヨウシナツト(黄)	TENSION NUT, YELLOW	
18-3	S20682102	1	イトチヨウシナツト(緑)	TENSION NUT, GREEN	
19	S20683001	1	ルーバイトアンナイ	LOOPER THREAD GUIDE	
20	060400812	1	バインドM4X8	SCREW, BIND M4X8	
21	146592001	2	イトアンナイパイプ	THREAD GUIDE PIPE	
22	S23452002	2	アナヒラ4X3.2	SET SCREW, SOCKET (FT) M4X3.2	
23	S20684101	1	イトアンナイドダイ	THREAD GUIDE BRACKET	
24	060400612	2	バインドM4X6	SCREW, BIND M4X6	
25	S20685001	1	シタルーバイトアンナイR	UNDER LOOPER THREAD GUIDE, R	
26	S20686001	1	ウワルーバイトアンナイR	OVER LOOPER THREAD GUIDE, R	
27	S23418002	2	シメネジ4X5	SCREW, M4X5	
28	S21133001	1	ウワルーバテンビンR	OVER LOOPER THREAD TAKE-UP, R	
29	S21134001	1	シタルーバテンビンR	UNDER LOOPER THREAD TAKE-UP, R	
30	060300412	1	バインドM3X4	SCREW, BIND M3X4	
31	S21135001	1	ルーバテンビンL	LOOPER THREAD TAKE-UP, L	
32	060400612	2	バインドM4X6	SCREW, BIND M4X6	
33	S21137001	1	ルーバイトアンナイM1	LOOPER THREAD GUIDE, M1	
35	S21136101	1	ウワルーバイトアンナイL	OVER LOOPER THREAD GUIDE, L	
36	060400612	1	バインドM4X6	SCREW, BIND M4X6	
37	S20687001	1	シタルーバイトアンナイL	UNDER LOOPER THREAD GUIDE, L	
38	S21127001	1	ハライトアンナイC	NEEDLE THREAD GUIDE (C)	
39	060400612	1	バインドM4X6	SCREW, BIND M4X6	
40	S21126001	1	ハライトアンナイB	NEEDLE THREAD GUIDE, B	
41	060400612	1	バインドM4X6	SCREW, BIND M4X6	
42-1	S21130051	1	ハライトテンピンA	NEEDLE THREAD TAKE-UP, A	
43	060400812	2	バインドM4X8	SCREW, BIND M4X8	
44	S21125001	1	ハライトアンナイA	NEEDLE THREAD GUIDE, A	
45	060400612	1	バインドM4X6	SCREW, BIND M4X6	
46	S38330050	1	ハライトオサエホルダー	NEEDLE THREAD PRESSER HOLDER	
47	146427001	2	アナトメネジ3.18クボミ	SET SCREW, SOCKET (CP) SM3.18	
48	S20689001	1	ハライトオサエカラー	NEEDLE THREAD PRESSER COLLAR	
49	S20690001	1	ハライトオサエバネ	SPRING	
50	S20691001	1	ハライトオサエイタ	NEEDLE THREAD PRESSER PLATE	
51	S20692001	1	ハライトアンナイ	NEEDLE THREAD GUIDE	
52	060300612	1	バインド M3X6	SCREW, BIND M3X6	
42-3	S21132001	1	<ソフトチェーン用> ハライトテンピンC	<FOR SOFT CHAIN> NEEDLE THREAD TAKE-UP, C	

P. 針冷却関係 / Needle cooler

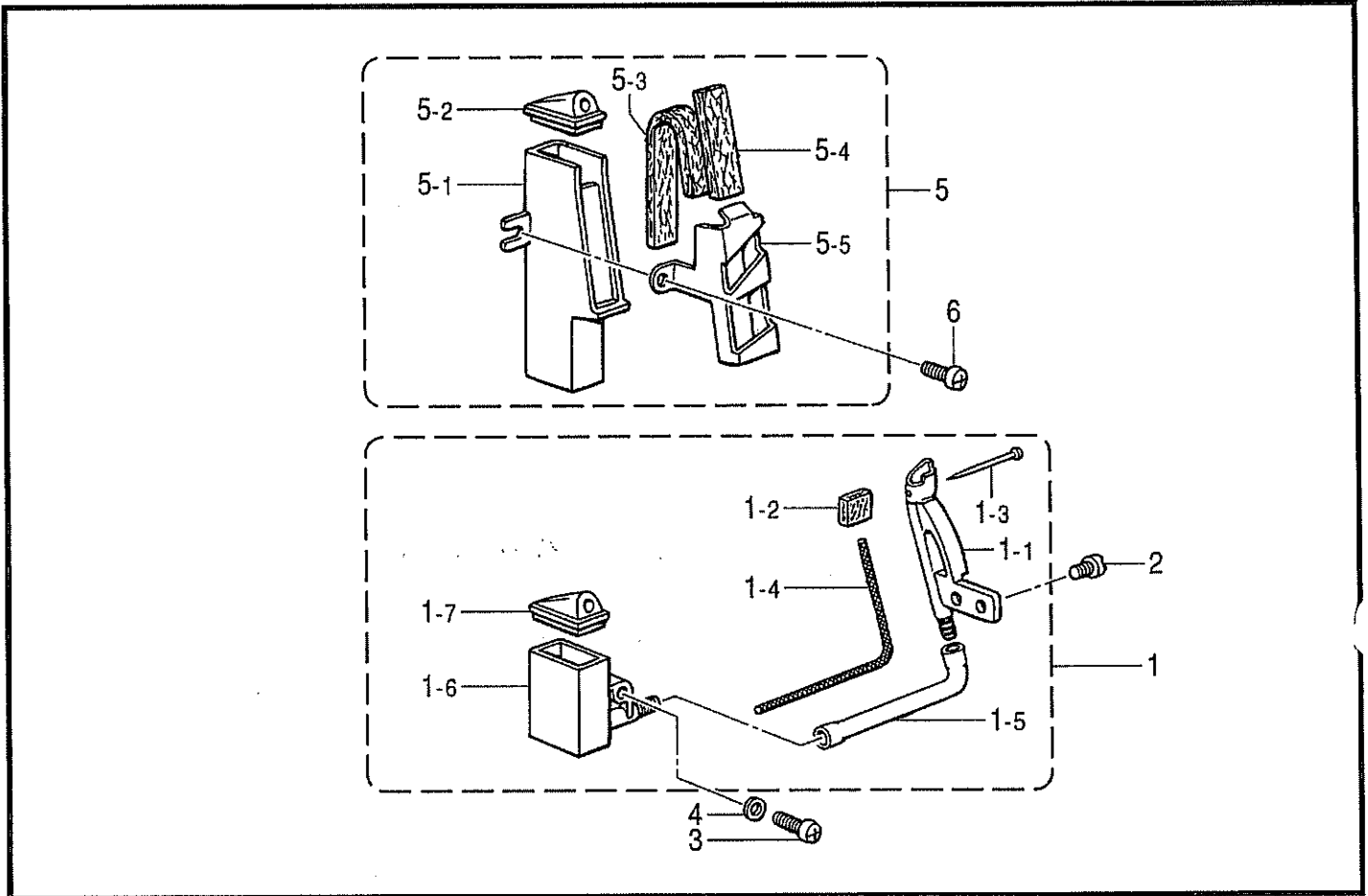

878-V7A,B-124

Q. 緑カガリ定規関係 / Serging attachment

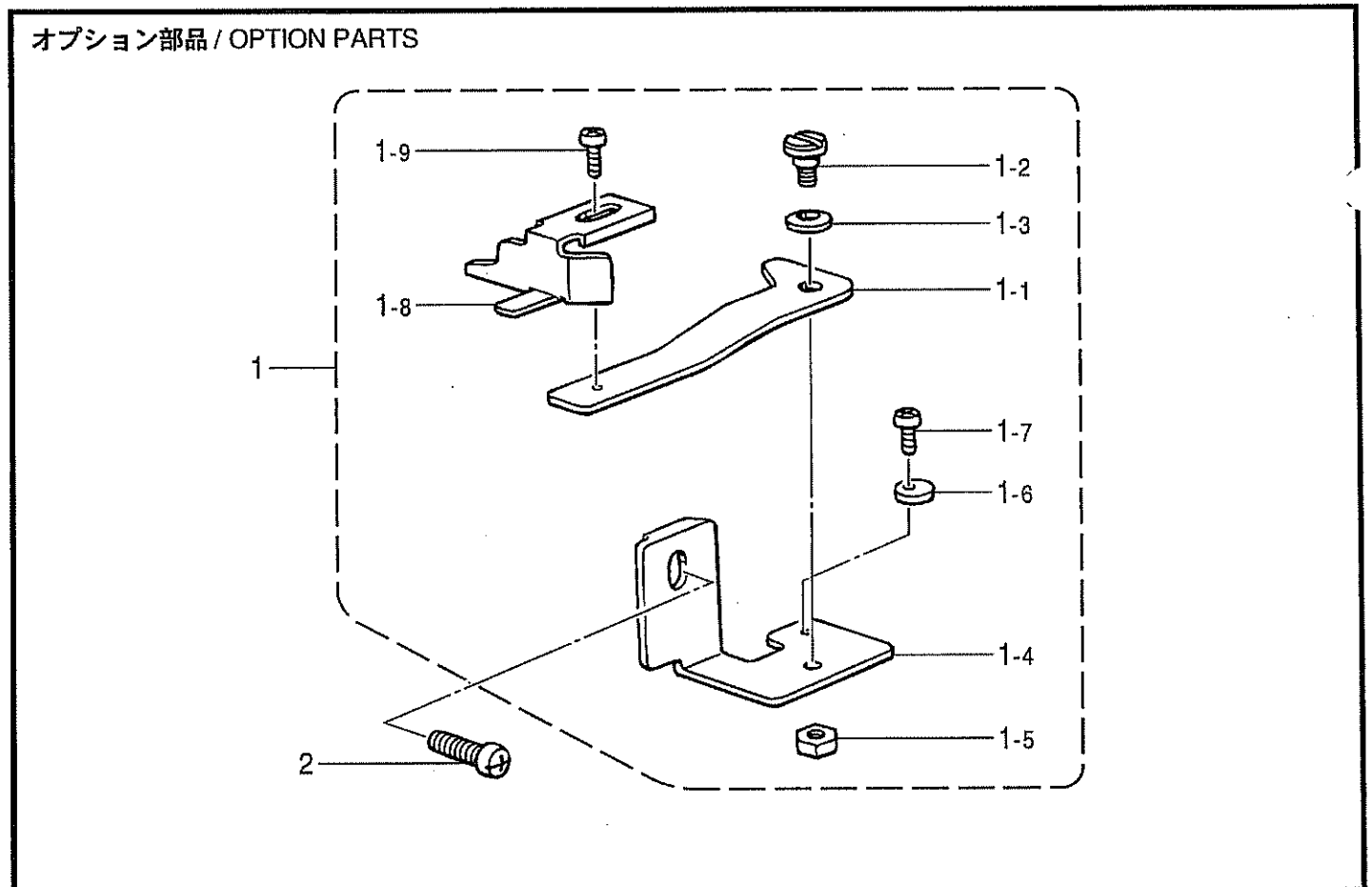

P. 針冷却関係 / Needle cooler

REF.NO.	CODE	Q'TY	ヒンメイ	NAME OF PARTS	RM
1	S20453001	1	フェルトササエクミ	FELT SUPPORT ASSY	
1-1	S20454000	1	フェルトササエ	FELT SUPPORT	
1-2	S20455000	1	フェルト	FELT	
1-3	S02874001	1	ムシピン	PIN	
1-4	150307000	1	クミヒモ	WICK (L = 140)	
1-5	S20456000	1	ビニルチューブ55	VINYL TUBE 55	
1-6	S20459000	1	シリコンタンクタイL	SILICONE TANK (L)	
1-7	S20460000	1	シリコンタンクフタ	SILICONE TANK CAP	
2	S23418002	2	シメネジ4X5	SCREW, M4X5	
3	060401012	1	バインドM4X10	SCREW, BIND M4X10	
4	025040132	1	ヒラザガネシヨウ4	WASHER, PLAIN S 4	
5	S20461101	1	シリコンタンククミU	SILICONE TANK ASSY (U)	
5-1	S20464000	1	シリコンタンクU	SILICONE TANK (U)	
5-2	S20460000	1	シリコンタンクフタ	SILICONE TANK CAP	
5-3	S29933000	1	フェルトL	FELT (L)	
5-4	S29934000	1	フェルトS	FELT (S)	
5-5	S20467001	1	フェルトオサエイタ	FELT SUPPORT PLATE	
6	062401012	1	ナベコM4X10	SCREW, PAN M4X10	

878-V7A,B-124

Q. 縁カガリ定規関係 / Serging attachment

REF.NO.	CODE	Q'TY	ヒンメイ	NAME OF PARTS	RM
1	S21336101	1	フチカガリジヨウギクミ	EDGE GUIDE ASSY	
1-1	S23896101	1	ジヨウギトリツケイタ	EDGE GUIDE SET PLATE	
1-2	S23773001	1	ダンネジ4	SHOULDER SCREW, M4	
1-3	146598001	1	バネザガネ	WASHER, SPRING	
1-4	S23897001	1	ジヨウギトリツケイタササエ	EDGE GUIDE SUPPORT	
1-5	021400212	1	2シユナツト4	NUT, 2 M4	
1-6	S21341001	1	ストツパー	STOPPER	
1-7	062300512	1	ナベコ3X5	SCREW, PAN M3X5	
1-8	146762001	1	フチカガリジヨウギ	EDGE GUIDE	
1-9	062350612	1	ナベコM3.5X6	SCREW, PAN M3.5X6	
2	062401012	1	ナベコM4X10	SCREW, PAN M4X10	

878-V7A,B-236

R. ラフラー装置関係 / Ruffling attachment

V72A  
3420  
3620

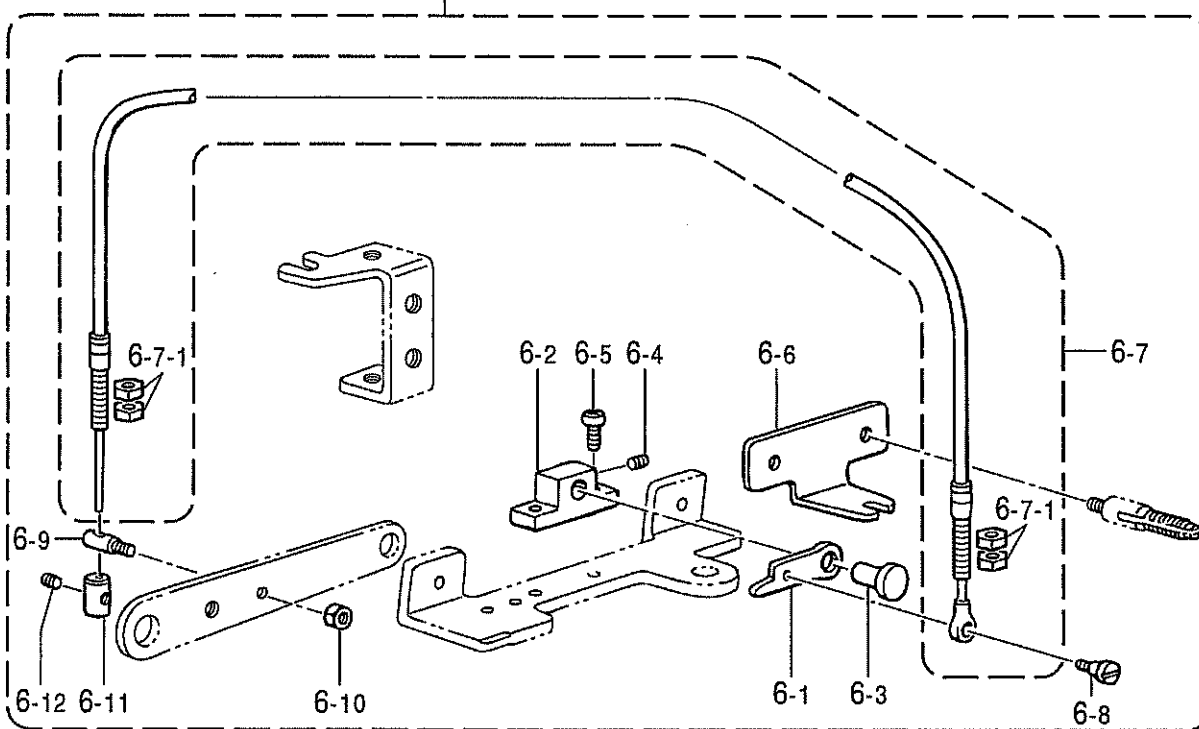
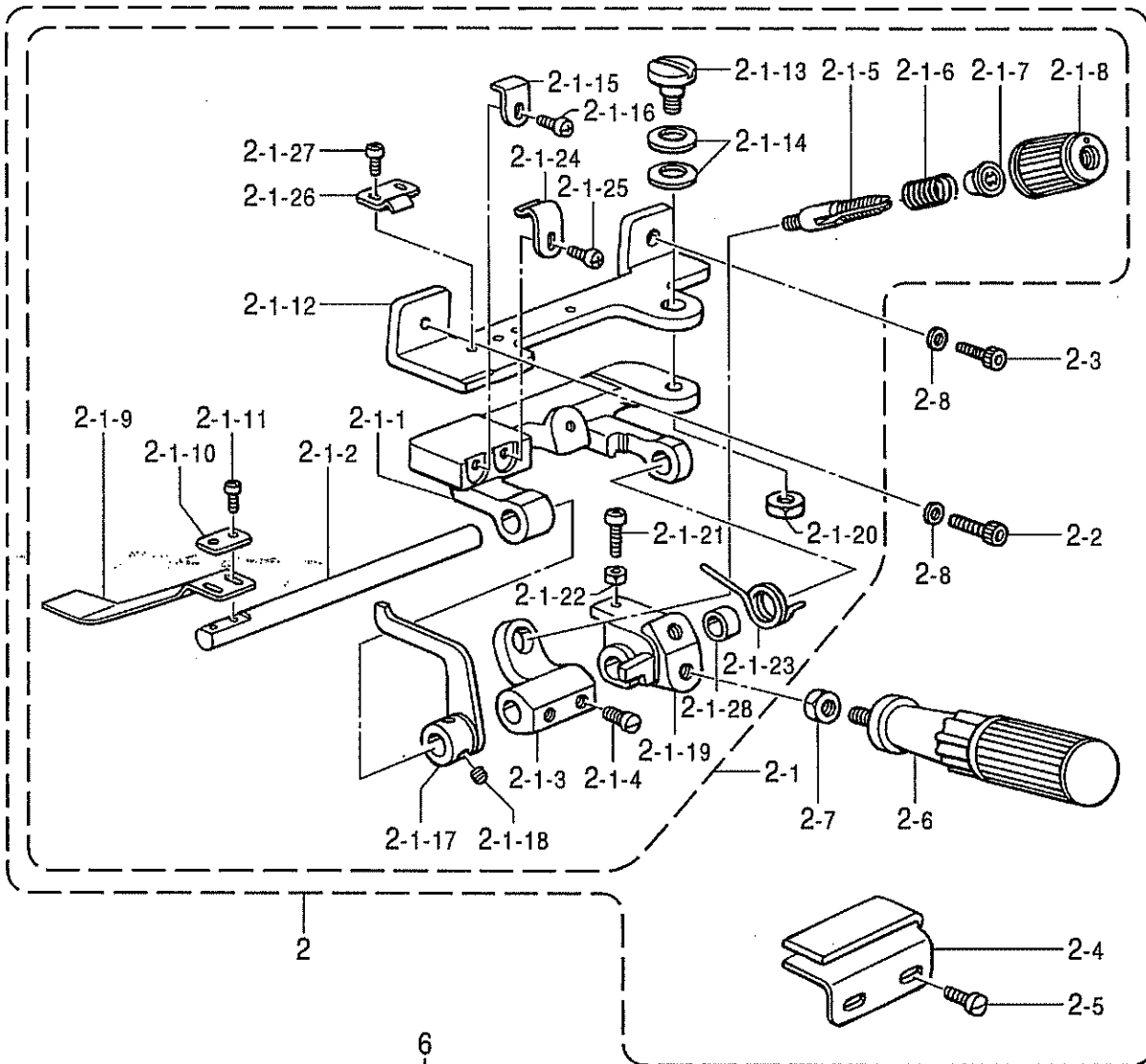



## R. ラフラー装置関係 / Ruffling attachment

REF.NO.	CODE	Q'TY	ヒンメイ	NAME OF PARTS	RM
2	S30401001	1	シャーリングクミ	SHIRRING ASSY	
2-1	S21365001	1	シャーリングソウチクミ	SHIRRING DEVICE SET	
2-1-1	S21294001	1	キジオサエタイ	RUFFLING BLADE BRACKET	
2-1-2	S21295001	1	キジオサエトリツケジク	RUFFLING BLADE BASE SHAFT	
2-1-3	S21305001	1	バネウケ	SPRING BASE	
2-1-4	S23777101	2	アタマツキトメネジ6	SET SCREW, M6	
2-1-5	S20676051	1	イトチヨウシボウ	TENSION STUD	
2-1-6	S23775001	1	コイルバネ	SPRING, COIL	
2-1-7	S20681000	1	チヨウシバネウエザガネ	WASHER	
2-1-8	S20682105	1	イトチヨウシナツト	TENSION NUT	
2-1-9	S21366001	1	キジオサエ	RUFFLING BLADE	
2-1-10	144784001	1	キジオサエザガネ	WASHER	
2-1-11	062300812	2	ナベコ3X8	SCREW, PAN M3X8	
2-1-12	S21297001	1	ラフラーソウチトリツケダイ	RUFFLER BASE	
2-1-13	S21306001	1	ダンネジ6	SHOULDER SCREW, M6	
2-1-14	S21307001	2	バネザガネ	WASHER, SPRING	
2-1-15	S21298001	1	キジオサエアンナイ	RUFFLING BLADE GUIDE	
2-1-16	062400812	1	ナベコ4X8	SCREW, PAN M4X8	
2-1-17	S21299001	1	キジオサエアゲ	CLOTH PRESSER BAR LIFTER	
2-1-18	S23651002	2	アナヒラ6X6ホソメ	SET SCREW, SOCKET (FT) M6X5	
2-1-19	S21300001	1	ハンドルトリツケイタ	HANDLE SETTING PLATE	
2-1-20	021060302	1	ナツト3シユ6	NUT, 3 M6	
2-1-21	062401612	1	ナベコM4X16	SCREW, PAN M4X16	
2-1-22	021400212	1	2シユナツト4	NUT, 2 M4	
2-1-23	S21301001	1	ハンドルモドシバネ	SPRING	
2-1-24	S21302001	1	キジオサエタイトメバネU	SPRING, PLATE (U)	
2-1-25	062400612	1	ナベコM4X6	SCREW, PAN M4X6	
2-1-26	S21303001	1	キジオサエタイトメバネD	SPRING, PLATE (D)	
2-1-27	062350512	2	ナベコ3.5X5	SCREW, PAN M3.5X5	
2-1-28	S21304001	1	カラー	COLLAR	
2-2	018401632	1	アナボルト4X16	BOLT, SOCKET M4X16	
2-3	018401032	1	アナボルト4X10	BOLT, SOCKET M4X10	
2-4	S21590000	1	キジアンナイ	RUFFLER GUIDE	
2-5	S23418002	2	シメネジ4X5	SCREW, M4X5	
2-6	S23779001	1	ハンドル	HANDLE	
2-7	021060302	1	ナツト3シユ6	NUT, 3 M6	
2-8	102707002	2	ザガネ	WASHER, PLAIN 4	
6	S30137001	1	ラフラーオサエレンドウクミ	RUFFLING DEVICE SET	
6-1	S21310001	1	キジオサエアゲレバー	CLOTH PRESSER BAR LIFTER LEVER	
6-2	S21311001	1	オサエアゲダイ	PRESSER BAR LIFTER BRACKET	
6-3	S21312001	1	ピン6.35	PIN, 6.35	
6-4	012060632	1	アナヒラ6X6	SET SCREW, SOCKET (FT) M6X6	
6-5	062350812	2	ナベコ3.5X8	SCREW, PAN M3.5X8	
6-6	S21313001	1	ワイヤートリツケイタ	WIRE SET PLATE	
6-7	S21314001	1	フレキシブルワイヤークミ	FLEXIBLE WIRE ASSY	
6-7-1	021500303	4	ナツト3シユ5	NUT, 3 M5	
6-8	S23774001	1	ダンネジ3.5	SHOULDER SCREW, M3.5	
6-9	S21315001	1	スタツドM4	STUD, M4	
6-10	021400212	1	2シユナツト4	NUT, 2 M4	
6-11	S21316001	1	ワイヤーストツパー	WIRE STOPPER	
6-12	012400432	1	アナヒラ4X4	SET SCREW, SOCKET (FT) M4X4	

R. ラフラー装置関係 / Ruffling attachment

V72A < 半沈用 / FOR SEMI-SUBMERGED >

3420  
3620

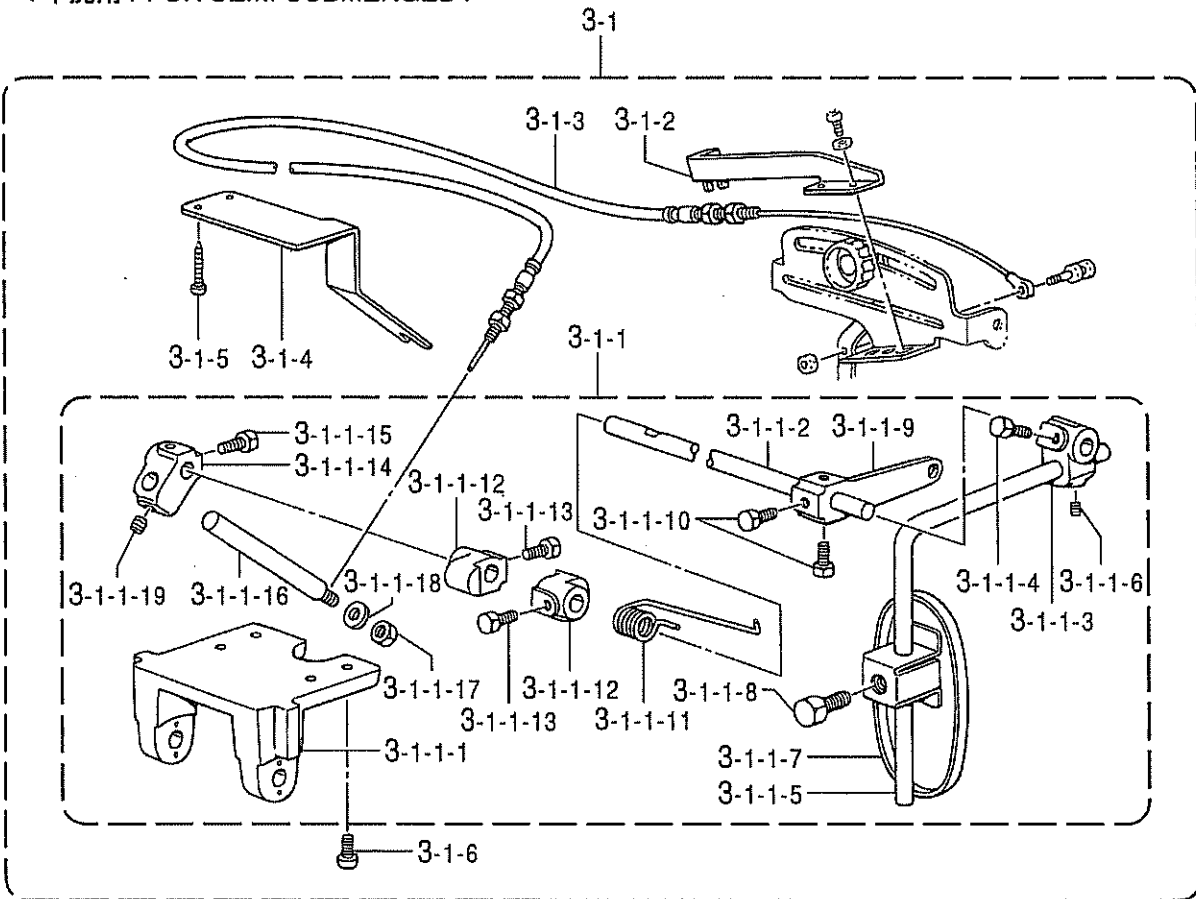

< 全沈用 / FOR FULL-SUBMERGED >

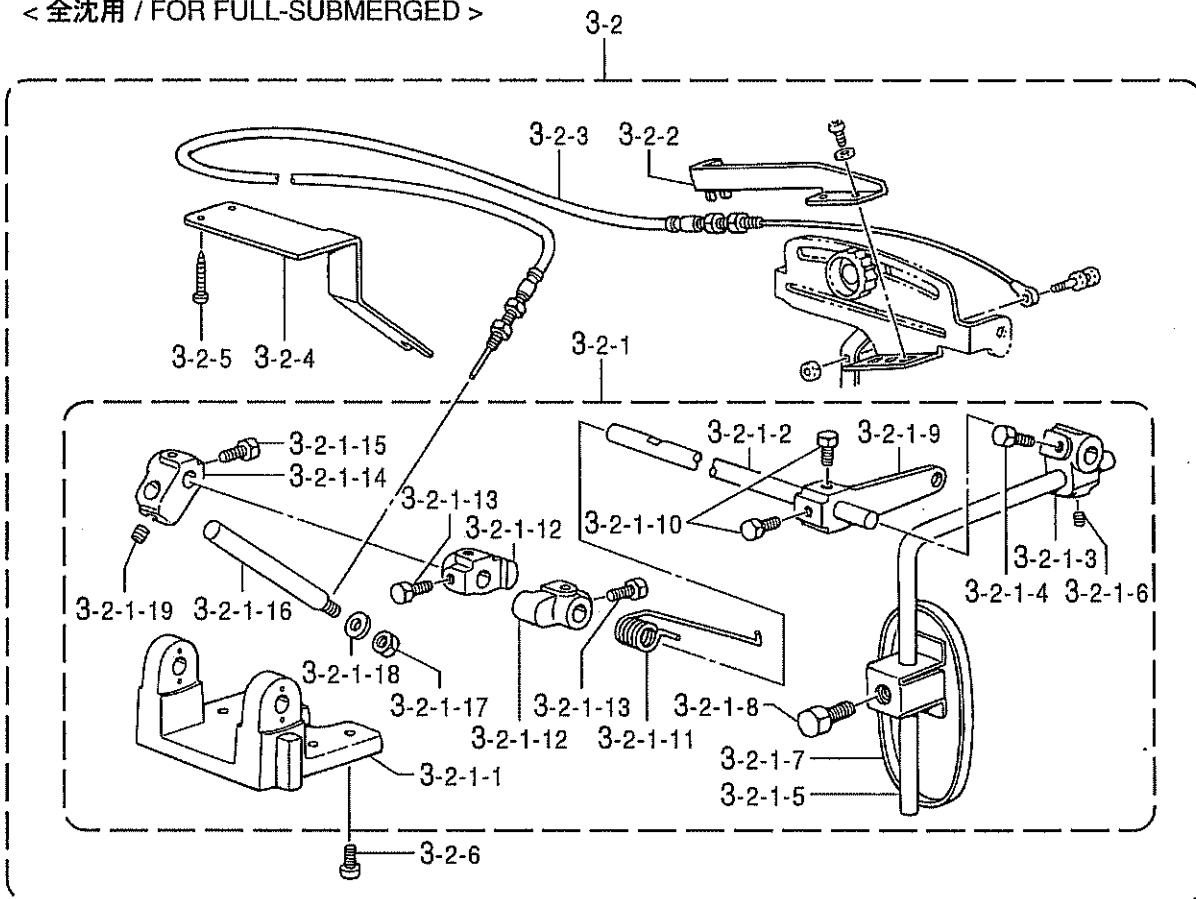

R. ラフラー装置関係 / Ruffling attachment

REF.NO.	CODE	Q'TY	ヒンメイ	NAME OF PARTS	RM
			<半沈用>	<FOR SEMI-SUBMERGED>	
3-1	S30402101	1	サドウチヨウセツセット	DIFFERENTIAL ADJUSTING SET	
3-1-1	S21387101	1	サドウチヨウセツクミ	DIFFERENTIAL FEED ADJUSTER	
3-1-1-1	155197101	1	ヒザアテヨコジクウケ	KNEE LIFTER SHAFT BRACKET	
3-1-1-2	S21388001	1	ヨコジク	KNEE LIFTER SHAET	
3-1-1-3	155199101	1	ヒザアテツギテ	KNEE LIFTER BRACKET	
3-1-1-4	017781012	2	ボルト6.35X10	BOLT, SM6.35X10	
3-1-1-5	148797001	1	ヒザアゲタテジクS	KNEE LIFTER BAR, S	
3-1-1-6	014780622	1	アナトメネジ6.35クボミ	SET SCREW, SOCKET (CP) SM6.35	
3-1-1-7	148798109	1	ヒザアテL	KNEE LIFTER PLATE, L	
3-1-1-8	017081606	1	ボルト8X16	BOLT, M8X16	
3-1-1-9	S21376001	1	ヒザアテレバー	KNEE LIFTER LEVER	
3-1-1-10	017781012	2	ボルト6.35X10	BOLT, SM6.35X10	
3-1-1-11	S21377001	1	ヒザアテレバーバネ	SPRING	
3-1-1-12	S21378001	2	ヨコジクトメグ	COLLAR	
3-1-1-13	017781012	4	ボルト6.35X10	BOLT, SM6.35X10	
3-1-1-14	155199101	1	ヒザアテツギテ	BRACKET, KNEE LIFTER	
3-1-1-15	017781012	2	ボルト6.35X10	BOLT SM6.35X10	
3-1-1-16	S21382001	1	ワイヤトリツケボウ	WIRE SET BAR	
3-1-1-17	110744002	1	ナツト6.35	NUT SM6.35	
3-1-1-18	025770232	1	ヒラザガネチユウ6.35	WASHER, PLAIN M 6.35	
3-1-1-19	014780622	1	アナトメネジ6.35クボミ	SET SCREW, SOCKET (CP) SM6.35	
3-1-2	S21385001	1	ワイヤトリツケイタ	WIRE SET PLATE	
3-1-3	S21283001	1	フレキシブルワイヤ	FLEXIBLE WIRE	
3-1-4	S21384001	1	ワイヤトリツケイタ	WIRE SET PLATE	
3-1-5	032422505	2	+マルモクネジ4.1X25	WOOD SCREW, ROUND M4.1X25	
3-1-6	062401012	4	ナベコM4X10	SCREW, PAN M4X10	
			<全沈用>	<FOR FULL-SUBMERGED>	
3-2	S30402102	1	サドウチヨウセツセット	DIF. ADJUSTING SET, FULL	
3-2-1	S21374101	1	サドウチヨウセツソウチクミ	DIFFERENTIAL FEED ADJUSTER	
3-2-1-1	155197101	1	ヒザアテヨコジクウケ	KNEE LIFTER SHAFT BRACKET	
3-2-1-2	S21388001	1	ヨコジク	KNEE LIFTER SHAET	
3-2-1-3	155199101	1	ヒザアテツギテ	KNEE LIFTER BRACKET	
3-2-1-4	017781012	2	ボルト6.35X10	BOLT, SM6.35X10	
3-2-1-5	148797001	1	ヒザアゲタテジクS	KNEE LIFTER BAR, S	
3-2-1-6	014780622	1	アナトメネジ6.35クボミ	SET SCREW, SOCKET (CP) SM6.35	
3-2-1-7	148798109	1	ヒザアテL	KNEE LIFTER PLATE, L	
3-2-1-8	017081606	1	ボルト8X16	BOLT, M8X16	
3-2-1-9	S21376001	1	ヒザアテレバー	KNEE LIFTER LEVER	
3-2-1-10	017781012	2	ボルト6.35X10	BOLT, SM6.35X10	
3-2-1-11	S21377001	1	ヒザアテレバーバネ	SPRING	
3-2-1-12	S21378001	2	ヨコジクトメグ	COLLAR	
3-2-1-13	017781012	4	ボルト6.35X10	BOLT, SM6.35X10	
3-1-1-14	155199101	1	ヒザアテツギテ	BRACKET, KNEE LIFTER	
3-1-1-15	017781012	2	ボルト6.35X10	BOLT SM6.35X10	
3-1-1-16	S21382001	1	ワイヤトリツケボウ	WIRE SET BAR	
3-1-1-17	110744002	1	ナツト6.35	NUT SM6.35	
3-1-1-18	025770232	1	ヒラザガネチユウ6.35	WASHER, PLAIN M 6.35	
3-1-1-19	014780622	1	アナトメネジ6.35クボミ	SET SCREW, SOCKET (CP) SM6.35	
3-1-2	S21385001	1	ワイヤトリツケイタ	WIRE SET PLATE	
3-1-3	S21283001	1	フレキシブルワイヤ	FLEXIBLE WIRE	
3-1-4	S21384001	1	ワイヤトリツケイタ	WIRE SET PLATE	
3-1-5	032422505	2	+マルモクネジ4.1X25	WOOD SCREW, ROUND M4.1X25	
3-2-6	062401012	4	ナベコM4X10	SCREW, PAN M4X10	

R. ラフラー装置関係 / Ruffling attachment

V72A  
3620

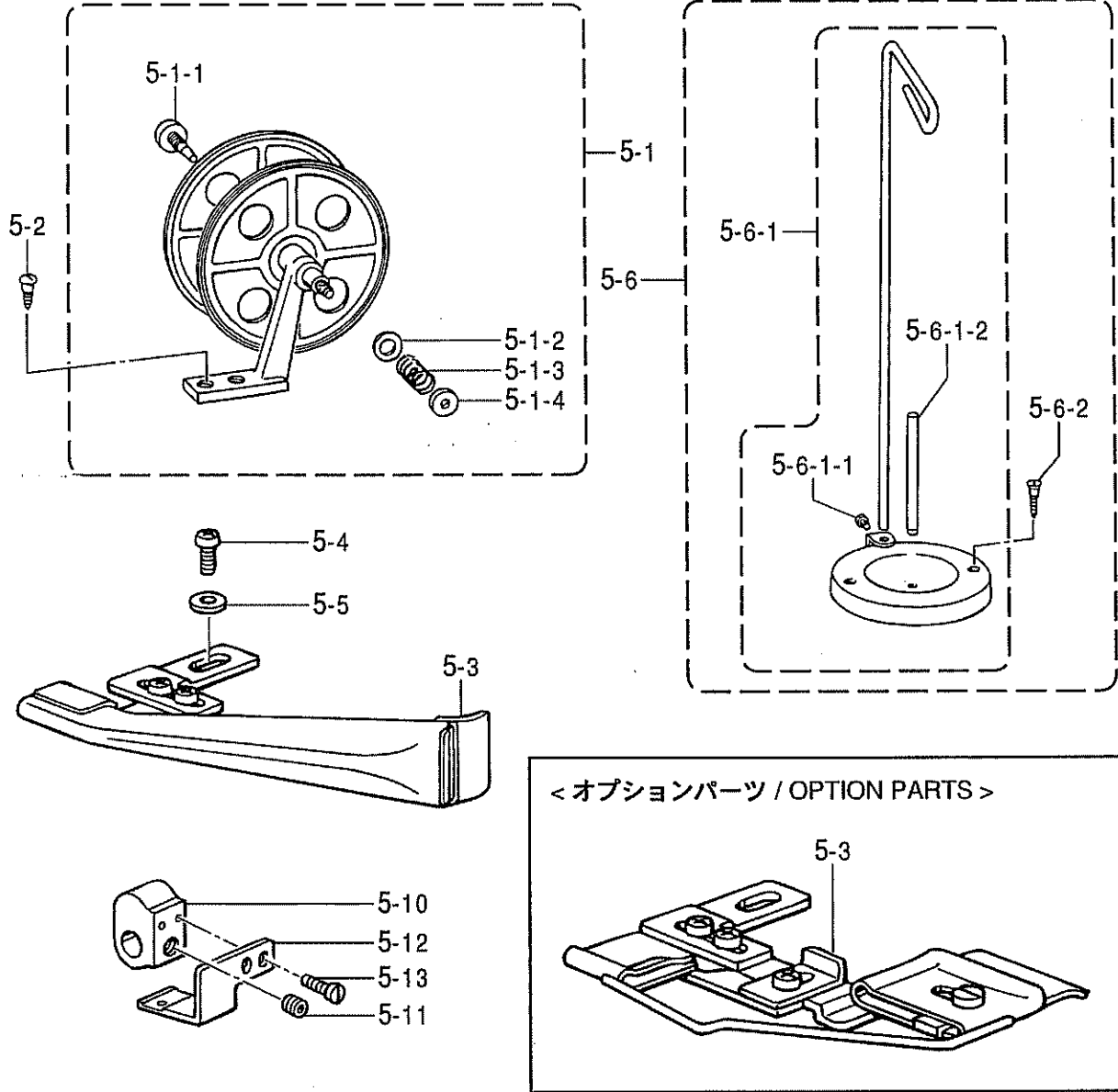

V72A  
3420  
3620

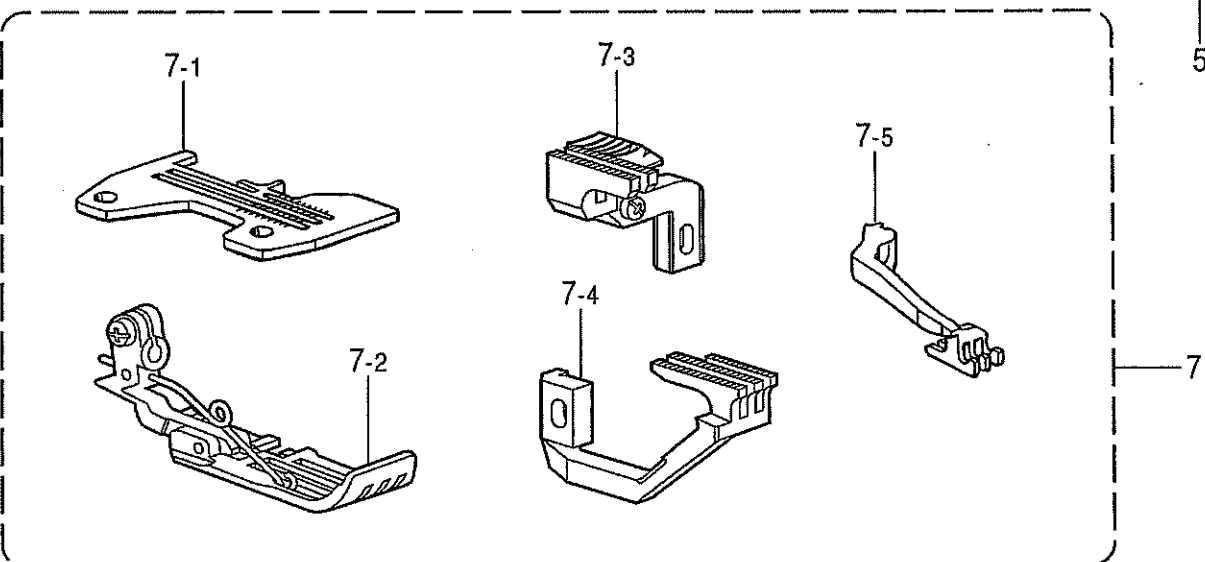

R. ラフラー装置関係 / Ruffling attachment

REF.NO.	CODE	Q'TY	ヒンメイ	NAME OF PARTS	RM
5	S30404001	1	パイピングパーツクミ	PIPING PARTS ASSY	
5-1	143767002	1	テープワインダークミ	TAPE WINDER ASSY	
5-1-1	143980001	1	ツمامネジ	SCREW	
5-1-2	108494001	1	ザガネ	WASHER	
5-1-3	108495001	1	テープワインダオシバネ	SPRING	
5-1-4	100136001	1	イトチヨウシナツト	TENSION NUT	
5-2	101118001	2	マルモクネジ4.5X20	WOOD SCREW, ROUND M4.5X20	
5-3	S21370001	1	ラツパークミ	LAPPER ASSY	
<オプション>				<OPTION PARTS>	
5-3	S21372001	1	ラツパークミ	LAPPER ASSY	
5-4	062350612	1	ナベコM3.5X6	SCREW, PAN M3.5X6	
5-5	025350332	1	ヒラザガネダイ3.5	WASHER, PLAIN L 3.5	
5-6	S20130009	1	イトタテダイクミネジツキ	COTTON STAND ASSY, W/SCREW	
5-6-1	S20131009	1	イトタテダイクミ	COTTON STAND ASSY	
5-6-1-1	S20134001	1	シメネジW476-24X10	SCREW, W4.76-24X10	
5-6-1-2	S20135001	1	イトタテボウ	SPOOL PIN	
5-6-2	034422006	2	+2サラモク41X20	WOOD SCREW, FLAT 2 M4.1X20	
5-10	S21368001	1	ラツパードダイ	LAPPER BASE	
5-11	S23651002	1	アナヒラ6X6ホソメ	SET SCREW, SOCKET (FT) M6X5	
5-12	S21369001	1	ラツハートリツケイタ	LAPPER SET PLATE	
5-13	S20355002	2	シメネジ3X8.5	SCREW, M3X8.5	
7	S30400001	1	シャーリングゲージクミ	SHIRRING GAUGE ASSY	
7-2	S19347001	1	オサエクミ	PRESSER FOOT ASSY	
<パイピング用>				<FOR PIPING>	
7	S30403001	1	P.シャーリングゲージクミ	PIPING SHIRRING GAUGE ASSY	
7-2	S19349001	1	オサエクミ	PRESSER FOOT ASSY	
7-1	S19155001	1	ハリイタ	NEEDLE PLATE	
7-3	S19212001	1	シユオクリバクミ	MAIN FEED DOG ASSY	
7-4	S19248001	1	サドウオクリバ	DIFFERENTIAL FEED DOG	
7-5	S19401001	1	ウワオクリバ	UPPER FEED DOG	

V72A	REF.NO.	3420-05		3620-05	
		半沈 Semi- Submerged	全沈 Full- Submerged	半沈 Semi- Submerged	全沈 Full- Submerged
シャーリングシヨウセット/SHIRRING SET		S30405101	S31111101	-	-
P. シャーリングシヨウセット/PIPING SHIRRING SET		-	-	S30406101	S31112101
シャーリングゲージクミ/SHIRRING GAUGE ASSY	7	S30400001	←	-	-
P. シャーリングゲージクミ/PIPING SHIRRING GAUGE ASSY	7	-	-	S30403001	←
シャーリングクミ/SHIRRING ASSY	2	S30401001	←	←	←
サドウチヨウセツセット/DIFFERENTIAL ADJUSTING SET	3	S30402101	S30402102	S30402101	S30402102
パイピングパーツクミ/PIPING PARTS ASSY	5	-	-	S30404001	←
ラフラーオサエレンドウクミ/RUFFLING DEVICE SET	6	S30137001	←	←	←

Z. 付属品関係 / Accessories

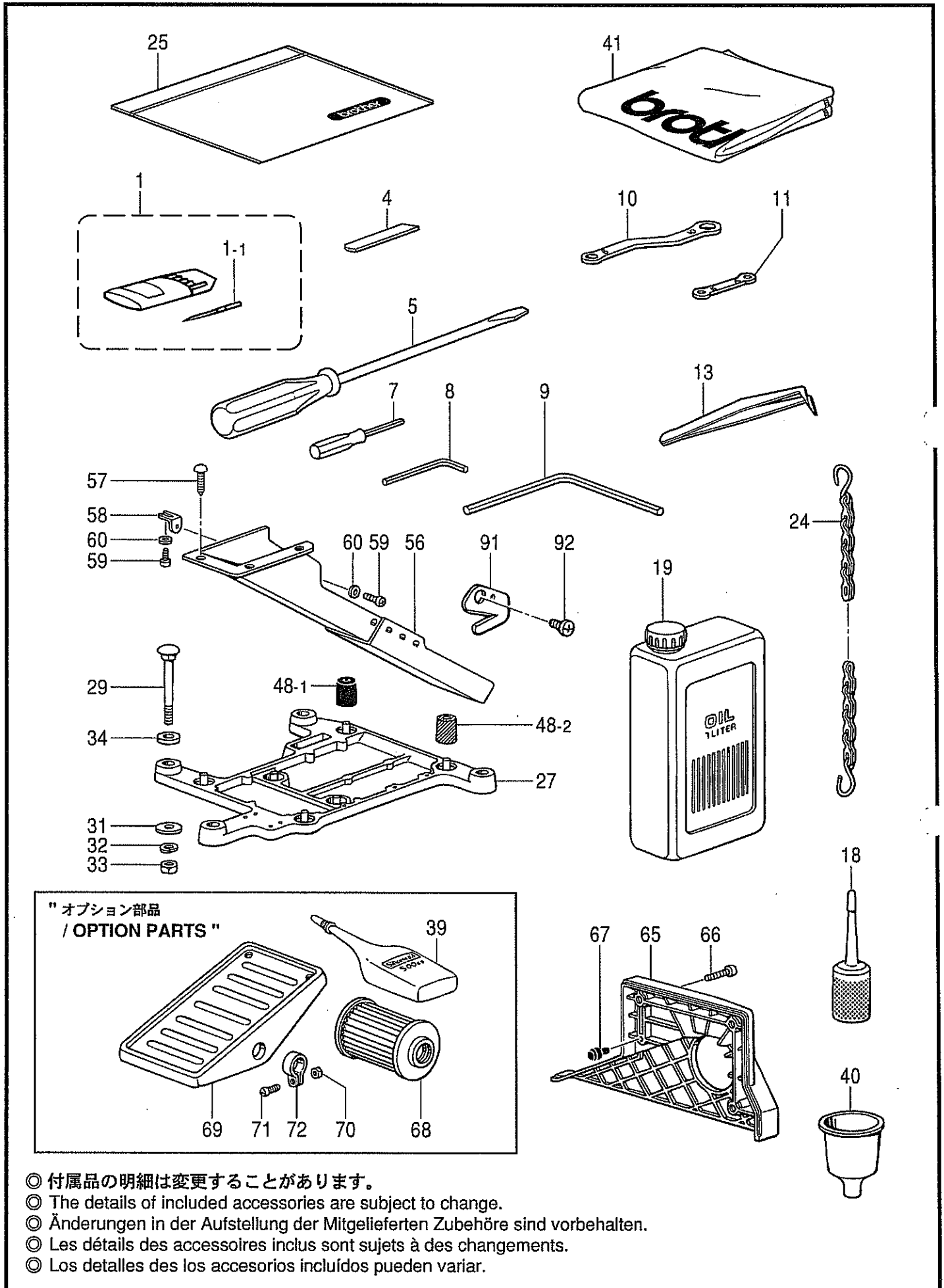

◎ 付属品の明細は変更することがあります。  
 ◎ The details of included accessories are subject to change.  
 ◎ Änderungen in der Aufstellung der Mitgelieferten Zubehöre sind vorbehalten.  
 ◎ Les détails des accessoires inclus sont sujets à des changements.  
 ◎ Los detalles de los accesorios incluidos pueden variar.

Z. 付属品関係 / Accessories

REF.NO.	CODE	Q'TY	ヒンメイ	NAME OF PARTS	RM
1		1	ミシンハリクミ	NEEDLE ASSY, DCX27	
1-1	※	4	ミシンハリ	NEEDLE, DCX27	
4	※	1	シタメス	LOWER KNIFE	
5	101572101	1	ネジマワシ5.5X190	SCREW DRIVER, 5.5X190	
7	S01943001	1	6カクボウネジマワシ1.6	SCREW DRIVER, 1.6	
8	142002001	1	6カクボウスパナ2	HEXAGONAL WRENCH, 2	
9	149570001	1	6カクボウスパナ5	HEXAGONAL WRENCH, 5	
10	S23356001	1	メガネレンチ8X10	DOUBLE WRENCH, 8X10	
11	S46907001	1	メガネレンチ5X6	DOUBLE WRENCH, 5X6	
13	117466000	1	ピンセット	PINCETTE	
18	S06701000	1	ポリオイラークミ	POLY OILER ASSY	
19	145277205	1	オイルタンク	OIL TANK	
24	142262001	1	クサリフクミ	CHAIN, F ASSY	
25	122991001	1	フゾクヒンポリフクロ	ACCESSORY BAG	
27	S20718000	1	トウブウケ	HEAD PLATE	
29	S35997001	4	カクネボルト8X85	BOLT, M8X85	
31	213650001	4	ワ2.3X8.5X38ST	WASHER, 2.3X8.5X38ST	
32	028080242	4	バネザガネ2-8	WASHER, SPRING 2-8	
33	021080106	4	ナツト1シユ8	NUT, 1 M8	
34	S20719000	4	クツシヨン	CUSHION	
39	S06704001	1	シリコンオイル	_____	
40	S20769000	1	ジョーゴ	FUNNEL	
41	144225002	1	トウブカバー	HEAD COVER	
48-1	147919051	1	ボウシンゴム	RUBBER CUSHION	
48-2	147919052	3	ボウシンゴム	RUBBER CUSHION	
56	183797009	1	ダスターシュートクミ	DUSTER CHUTE ASSY	
57	031411304	3	マルモクネジ4.1X13	WOOD SCREW, ROUND M4.1X13	
58	S23353001	1	ダスターシュートササエS	DUSTER SHOOT SUPPORT, S	
59	062400612	2	ナベコM4X6	SCREW, PAN M4X6	
60	025040332	2	ヒラザガネダイ4	WASHER, PLAIN L 4	
65	S38645001	1	ベルトカバークミ	BELT COVER ASSY	
66	062061412	3	ナベコ6X14	SCREW, PAN M6X14	
67	S20412000	1	ゴムセン3.7	RUBBER CAP, 3.7	
68	S08956100	1	オイルフィルター	_____	
69	147893009	1	オサエアゲフミイタ	_____	
70	021400106	2	ナツト1シユ4	_____	
71	062401406	2	ナベコ4X14	_____	
72	116016001	2	ペタルトメ	_____	
91	S20118151	1	カラヌイメス	TRIMMING KNIFE	
92	060300512	1	<V71A> バインドM3X5	<V71A> SCREW, BIND M3X5	
92	060300412	1	<V72A> バインドM3X4	<V72A> SCREW, BIND M3X4	
39	S06704001	1	_____	<OPTION PARTS> SILICONE OIL	
68	S08956100	1	_____	OIL FILTER	
69	147893009	1	_____	TREADLE PEDAL	
70	021400106	2	_____	NUT, 1M4	
71	062401406	2	_____	SCREW, PAN M4X14	
72	116016001	2	_____	PEDAL STOPPER	

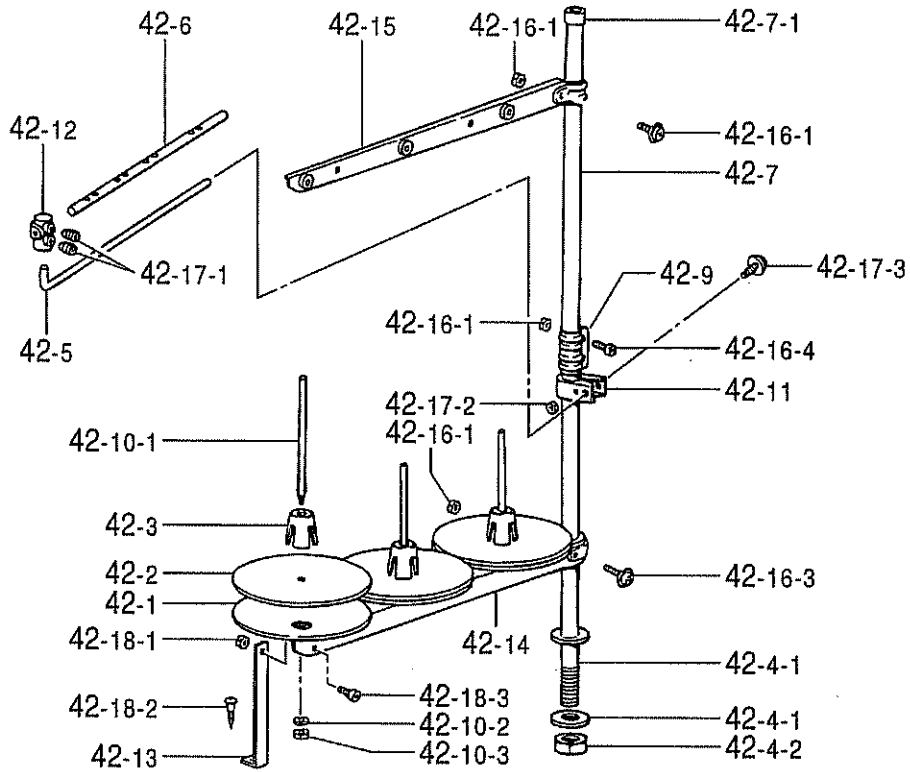

" オプション部品 / OPTION PARTS "

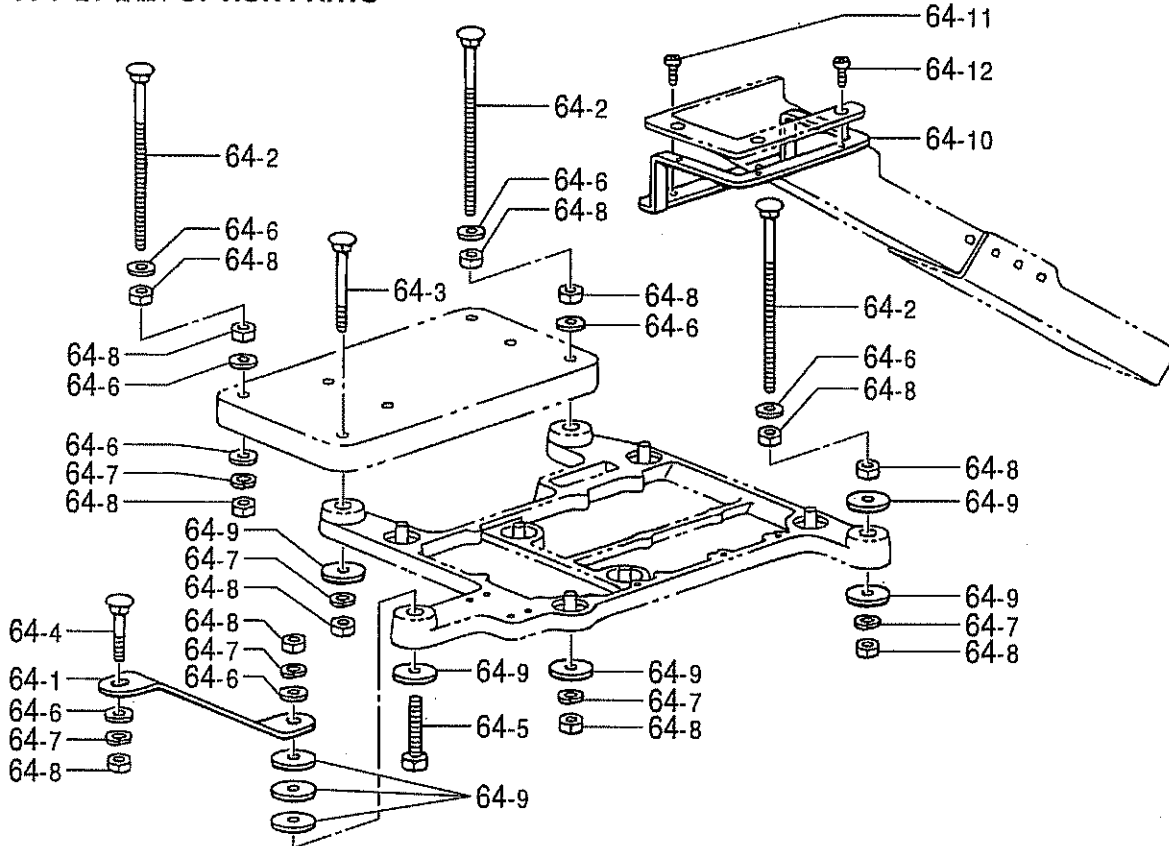











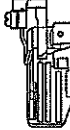



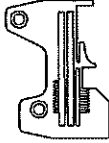
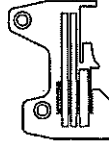
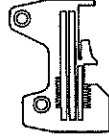





- ◎ 付属品の明細は変更することがあります。
- ◎ The details of included accessories are subject to change.
- ◎ Änderungen in der Aufstellung der Mitgelieferten Zubehöre sind vorbehalten.
- ◎ Les détails des accessoires inclus sont sujets à des changements.
- ◎ Los detalles de los accesorios incluidos pueden variar.



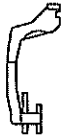

## Z. 付属品関係 / Accessories

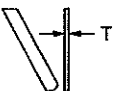
REF.NO.	CODE	Q'TY	ヒンメイ	NAME OF PARTS	RM
42	S29853109	1	イトタテダイクミ3DTHF	COTTON STAND ASSY, 3DTHF	
42-1	150180001	3	ウケザラ	SPOOL STAND BASE	
42-2	150182000	3	スプールマット	SPOOL MAT	
42-3	126863001	3	スプールクッション	SPOOL CUSHION	
42-4	S02775001	1	パイプネジセットA	PIPE SCREW SET, A	
42-4-1	150206002	1	ヒラザガネ16	WASHER, PLAIN 16	
42-4-2	S38648001	1	6カクナツトU5/8	NUT, U5/8-28	
42-5	S04109001	1	イトアンナイササエボウ	THREAD GUIDE SUPPORT BAR	
42-6	142997001	1	イトアンナイ3	THREAD GUIDE, 3	
42-7	S40640001	1	コラムパイプキャップツキ	COLUMN PIPE WITH CAP	
42-7-1	150174000	1	コラムキャップ	COLUMN CAP	
42-8	156112003	1	コラムパイプD	COLUMN PIPE, D	
42-9	150173003	1	コラムジョイント	COLUMN JOINT	
42-10	S21798001	3	スプールネジセット	SPOOL SCREW SET	
42-10-1	150179002	3	スプールジクB	SPOOL SHAFT, B	
42-10-2	028050246	3	バネザガネ2-5	WASHER, SPRING 2-5	
42-10-3	021500106	3	1シユナツト5	NUT, 1 M5	
42-11	150185009	1	イトアンナイホルダー	THREAD GUIDE HOLDER	
42-12	138843001	1	ササエボウツギテ	JOINT	
42-13	150188009	1	スプールホルダーササエA	SPOOL HOLDER SUPPORT, A	
42-14	S02779009	1	スプールホルダー3	SPOOL HOLDER, 3	
42-15	S02788009	1	スレツドハンガークミ3	THREAD HANGER ASSY, 3	
42-16	S40641001	1	スプールジクネジセットA	SPOOL SCREW SET, A	
42-16-1	021500106	4	1シユナツト5	NUT, 1 M5	
42-16-2	S37038001	1	ナベコヒラザ5X14	SCREW, PAN (S/P WASHER) M5X14	
42-16-3	S37037001	1	ナベコヒラザ5X32	SCREW, PAN (S/P WASHER) M5X32	
42-16-4	062501406	2	ナベコ5X14	SCREW, PAN M5X14	
42-17	S40643001	1	ホルダーツギテネジセット	HOLDER JOINT SCREW SET	
42-17-1	014060632	2	アナクボミ6X6	SET SCREW, SOCKET (CP) M6X6	
42-17-2	021500106	1	1シユナツト5	NUT, 1 M5	
42-17-3	S37037001	1	ナベコヒラザ5X32	SCREW, PAN (S/P WASHER) M5X32	
42-18	S40644001	1	ホルダーツギテネジセット	HOLDER JOINT SCREW SET	
42-18-1	021500106	1	1シユナツト5	NUT, 1 M5	
42-18-2	031452206	1	マルモク45X22	WOOD SCREW, ROUND M4.5X22	
42-18-3	062501006	1	ナベコ5X10	SCREW, PAN M5X10	
64	183798001	1	フルサブマージセット	FULL SUBMERGED SET	
64-1	S20721001	1	トウブウケササエ	HEAD PLATE SUPPORT	
64-2	153318201	4	カクネマルアタマボルト	BOLT	
64-3	S35997001	1	カクネボルト8X85	BOLT, M8X85	
64-4	S36007001	1	カクネボルト8X55	BOLT, M8X55	
64-5	017085502	1	ボルトM8X55	BOLT, M8X55	
64-6	025080236	11	ヒラザガネチユウ8	WASHER, PLAIN M 8	
64-7	028080242	7	バネザガネ2-8	WASHER, SPRING 2-8	
64-8	021080106	15	ナツト1シユ8	NUT, 1 M8	
64-9	213650001	8	ワ2.3X8.5X38ST	WASHER, 2.3X8.5X38ST	
64-10	S20722001	1	ダスターシュートササエL	DUSTER SHOOT SUPPORT, L	
64-11	060400812	2	バインドM4X8	SCREW, BIND M4X8	
64-12	060400812	3	バインドM4X8	SCREW, BIND M4X8	

Ga. ゲージ部品一覧表 / Gauge parts List

用途 Application	一般地縫用 Thin Medium		一般地縫用 (小回り用) Thin Medium ( Small type )	バルキーニット用 Bulky knit	シャーリング用 Shirring	シャーリング用 パイピング付 Shirring W / Piping
機種 Model	V71A	V72A	V72A	V72A	V72A	V72A
サブクラス Sub-Class H=High-Lift E=Extra High-Lift	3020-03-H8F -04-H8F -05-H8F	3020-04-H8F -05-H8F -06-H8F	3021-03-H8F -04-H8F -05-H8F	3060-05-E8V -06-E8V -07-E8V	3420-05-E8F	3620-05-E8F
1 針 Needle	151474-011			151474-014	151474-011	
2 押工組 Presser Foot Assy	S21223-001 ( 3 ) ( S19257-001 ) S19341-001 ( 4, 5 ) ( S19261-001 ) (ツメ Stitch Tongue) 	S19343-001 ( 4 ) S19347-001 ( 5 ) S25825-001 ( 6 ) 	S25823-001 ( 3 ) S25081-001 ( 4 ) S25084-001 ( 5 ) 	S19347-001 ( 5 ) S25825-001 ( 6 ) S25827-001 ( 7 ) 	S19347-001 	S19349-001 
3 針板 Needle Plate	S33024-001 ( 3 ) S19154-001 ( 4 ) S19155-001 ( 5 ) S19161-001 ( 6 ) 			S19147-001 ( 5 ) S19148-001 ( 6 ) S25186-001 ( 7 ) 	S19155-001 ( 5 ) 	
4 主送り歯組 Main Feed Dog Assy (主送り歯 Main Feed Dog) (補助送り歯 Chain Feed Dog)	S19212-001 ( S19213-001 ) ( S19204-001 ) B 			S19202-001 ( S19955-001 ) ( S19204-001 ) B 	S19212-001 ( S19213-001 ) ( S19204-001 ) B 	
5 差動送り歯 Differential Feed Dog	S33027-001 ( 3 ) S19240-001 ( 4, 5 ) 	S33026-001 ( 3 ) S19248-001 ( 4, 5, 6 ) 	S25568-101 		S19248-001 	
6 上送り歯 Upper Feed Dog	S19400-001 	S19401-001 	S25097-001 	S19401-001 		
7 上メス Upper Knife 角メス Angle Knife	上メス Upper knife 144074-350 			角メス Angle knife S20897-101 	上メス Upper knife 144074-350 	
8 下メス Lower Knife 	( 3 ) S20899-001 ( T=1.0 ) ( 4, 5, 6 ) S20582-001 ( T=1.5 )			( 5 ) S20899-001 ( T=1.0 ) ( 6, 7 ) S20582-001 ( T=1.5 )	S20582-001 ( T=1.5 )	
9 上ルーパ Over Looper 	S20426-001 H			S20438-101 G		

Wa. 警告ラベル / Warning labels

警告ラベル / Warning labels	品名 / Name of parts	Size(mm)	Code
	操作注意ラベル・和	40X64	S38350-001
	Label, operation Eng.	40X64	S38349-001
	アースマーク Mark, grounding	ø12	S37060-001

878-V7A,B-052

## 索引 / INDEX

CODE	REF.NO.	Page
S00075000	A -66	4
S00204001	F -99	20
S01943001	Z -7	42
S02573000	E -38	14
S02606000	A -3	2
S02775001	Z -42-4	44
S02779009	Z -42-14	44
S02788009	Z -42-15	44
S02874001	P -1-3	34
S04109001	Z -42-5	44
S06701000	Z -18	42
S06704001	Z -39	42
	Z -39	42
S07463000	L -51	30
S07477009	A -84	4
S08956100	L -8	28
	Z -68	42
	Z -68	42
S08957001	L -7	28
S12987002	L -10	28
S19147001	Ga -3	45
S19148001	Ga -3	45
S19154001	Ga -3	45
S19155001	R -7-1	40
	Ga -3	45
S19161001	Ga -3	45
S19202001	Ga -4	45
S19204001	Ga -4	45
S19212001	R -7-3	40
	Ga -4	45
S19213001	Ga -4	45
S19240001	Ga -5	45
S19248001	R -7-4	40
	Ga -5	45
S19257001	Ga -2	45
S19261001	Ga -2	45
S19279001	D -50-1-4	12
S19341001	Ga -2	45
S19343001	Ga -2	45
S19346001	D -50-1-1	12
	D -50-4-1	12
S19347001	R -7-2	40
	Ga -2	45
S19349001	R -7-2	40
	Ga -2	45
S19400001	Ga -6	45
S19401001	R -7-5	40
	Ga -6	45
S19496001	D -50-1-2	12
S19535001	D -51	12
	D -51	12
S19955001	Ga -4	45
S20118151	Z -91	42
S20130009	R -5-6	40
S20131009	R -5-6-1	40
S20134001	R -5-6-1-1	40
S20135001	R -5-6-1-2	40
S20139101	F -1	18
S20144000	F -3	18
S20145001	F -4	18
S20146001	F -8	18
S20147001	F -13	18
S20151001	F -15	18

CODE	REF.NO.	Page
S20152001	F -14	18
S20153001	F -17	18
	F -54	20
S20154001	F -21	18
S20155000	F -59	20
S20156000	F -23	18
	F -60	20
S20157001	F -26	18
S20158101	F -13-2	18
	F -52-2	20
	L -53	30
	L -56	30
S20159001	F -30	18
S20160001	F -32	18
	F -71	20
S20161101	F -34	18
S20162001	F -36	18
S20163001	F -42	18
S20165001	F -45	18
S20168001	F -52	20
S20172001	F -53	20
S20174001	F -58	20
S20175101	F -5	18
	F -13-1	18
	F -18	18
	F -52-1	20
	F -55	20
S20176001	F -64	20
S20177001	F -69	20
S20178001	L -57	30
S20179001	F -72	20
S20180001	L -29	28
S20181001	F -82	20
S20182001	F -82-1	20
S20183001	F -84	20
S20184101	F -50	18
S20189001	F -33	18
	F -83	20
	F -104	20
S20191001	F -82-3	20
S20193001	F -92	20
S20194001	F -95	20
S20195001	F -97	20
S20197001	F -24	18
	F -28	18
	F -62	20
	F -67	20
S20199001	L -14	28
	L -16	28
	L -18	28
S20200001	L -30	28
S20201001	F -101	20
S20202001	F -100	20
S20204001	A -2	2
S20207101	A -57	4
S20208001	A -56	4
S20209001	D -20	10
S20213000	L -40	30
S20214000	L -42	30
S20215001	L -43	30
S20216000	L -45	30
S20217001	L -46	30
S20218001	L -49	30

CODE	REF.NO.	Page
S20219001	L -50	30
S20220001	L -52	30
S20221000	L -54	30
S20222001	L -55	30
S20298001	D -36	10
S20300101	L -4	28
S20301001	L -4-3	28
S20303000	L -4-4	28
S20306000	A -5	2
S20309101	A -11	2
S20310001	A -13	2
S20311000	A -14	2
S20313000	A -20	2
S20314000	A -21	2
S20319001	A -27-3	2
S20320101	A -27-5	2
S20321001	A -27-6	2
S20323101	A -29	2
S20324101	A -33	2
S20325001	A -35	2
S20327101	A -27-8	2
S20328001	A -37	2
S20330100	A -39	2
S20331001	A -40	2
S20334000	A -43	2
S20337001	A -59	4
S20338200	A -61	4
S20339000	A -62	4
S20340001	A -69	4
S20342001	A -70	4
S20344009	A -74	4
S20345009	A -10	2
	A -75	4
S20346000	A -80	4
S20353000	B -21	6
S20355002	H -9-2-2	24
	R -5-13	40
S20356001	B -11	6
S20357000	B -30	6
S20361001	B -17	6
S20362151	B -18	6
S20386101	C -7	8
S20391001	C -7-4	8
S20392000	C -7-5	8
	L -34	28
S20393101	C -8	8
S20396001	C -12	8
S20412000	A -48	2
	A -55	4
	Z -67	42
S20413051	C -18	8
S20414001	C -20	8
S20415101	C -22	8
S20416101	C -23	8
S20426001	Ga -9	45
S20438101	Ga -9	45
S20453001	P -1	34
S20454000	P -1-1	34
S20455000	P -1-2	34
S20456000	P -1-5	34
S20459000	P -1-6	34
S20460000	P -1-7	34
	P -5-2	34

CODE	REF.NO.	Page
S20461101	P -5	34
S20464000	P -5-1	34
S20467001	P -5-5	34
S20472001	D -1	10
S20477001	D -4	10
S20485001	D -19	10
S20489001	D -23	10
S20494001	D -41	12
S20496101	E -1	14
S20500001	E -1-2	14
	F -1-1	18
S20500002	E -1-2	14
	F -1-1	18
S20500003	E -1-2	14
	F -1-1	18
S20507001	E -3-1	14
S20523000	E -43	14
S20524000	E -44	14
S20525001	E -45	14
S20526000	E -47	14
S20527001	E -83	16
S20530001	E -30	14
S20543101	E -51	14
S20544000	E -52	14
S20546001	F -27	18
	F -65	20
S20547001	E -55	16
S20548001	E -59	16
S20554001	E -58	16
S20560001	E -66	16
	F -41	18
	F -78	20
S20561001	E -67	16
S20571101	G -2	22
S20574001	G -8	22
S20575001	G -9-1	22
S20576001	G -9-2	22
S20577001	G -12	22
S20578101	G -13	22
S20579101	G -15-2	22
S20580101	G -17	22
S20582001	Ga -8	45
S20585001	G -27	22
S20598000	H -2	24
	J -3	26
S20601001	H -5	24
S20621001	F -105	20
	J -4	26
S20625151	J -11	26
S20626001	J -14	26
S20655101	L -1	28
S20657001	L -4-1	28
S20661001	L -4-5	28
S20662100	L -4-6	28
S20663000	L -4-7	28
S20666001	L -17	28
S20668200	L -22	28
S20669000	L -24	28
S20672001	M -1	32
S20673001	M -11	32
S20674001	M -5	32
S20675001	M -8	32
S20676051	M -9	32

CODE	REF.NO.	Page
S20676051	R -2-1-5	36
S20677000	M -10	32
S20678001	M -14	32
S20679001	M -15	32
S20681000	M -17	32
	R -2-1-7	36
S20682102	M -18-3	32
S20682103	M -18-1	32
S20682104	M -18-2	32
S20682105	R -2-1-8	36
S20683001	M -19	32
S20684101	M -23	32
S20685001	M -25	32
S20686001	M -26	32
S20687001	M -37	32
S20689001	M -48	32
S20690001	M -49	32
S20691001	M -50	32
S20692001	M -51	32
S20718000	Z -27	42
S20719000	Z -34	42
S20721001	Z -64-1	44
S20722001	Z -64-10	44
S20740101	E -46	14
S20769000	Z -40	42
S20842001	D -50-1-2	12
S20878000	A -19	2
	A -82	4
S20896101	G -15-2	22
S20897101	G -15-2	22
	Ga -7	45
S20898101	G -15-2	22
S20899001	Ga -8	45
S21091000	E -81	16
S21092000	E -81-1	16
S21125001	M -44	32
S21126001	M -40	32
S21127001	M -38	32
S21130051	M -42-1	32
S21132001	M -42-3	32
S21133001	M -28	32
S21134001	M -29	32
S21135001	M -31	32
S21136101	M -35	32
S21137001	M -33	32
S21223001	Ga -2	45
S21283001	R -3-1-3	38
	R -3-1-3	38
S21294001	R -2-1-1	36
S21295001	R -2-1-2	36
S21297001	R -2-1-12	36
S21298001	R -2-1-15	36
S21299001	R -2-1-17	36
S21300001	R -2-1-19	36
S21301001	R -2-1-23	36
S21302001	R -2-1-24	36
S21303001	R -2-1-26	36
S21304001	R -2-1-28	36
S21305001	R -2-1-3	36
S21306001	R -2-1-13	36
S21307001	R -2-1-14	36
S21310001	R -6-1	36
S21311001	R -6-2	36

CODE	REF.NO.	Page
S21312001	R -6-3	36
S21313001	R -6-6	36
S21314001	R -6-7	36
S21315001	R -6-9	36
S21316001	R -6-11	36
S21336101	Q -1	34
S21341001	Q -1-6	34
S21365001	R -2-1	36
S21366001	R -2-1-9	36
S21368001	R -5-10	40
S21369001	R -5-12	40
S21370001	R -5-3	40
S21372001	R -5-3	40
S21374101	R -3-2-1	38
S21376001	R -3-1-1-9	38
	R -3-2-1-9	38
S21377001	R -3-1-1-11	38
	R -3-2-1-11	38
S21378001	R -3-1-1-12	38
	R -3-2-1-12	38
S21382001	R -3-1-1-16	38
	R -3-1-1-16	38
S21384001	R -3-1-4	38
	R -3-1-4	38
S21385001	R -3-1-2	38
	R -3-1-2	38
S21387101	R -3-1-1	38
S21388001	R -3-1-1-2	38
	R -3-2-1-2	38
S21590000	R -2-4	36
S21798001	Z -42-10	44
S23337009	A -7	2
	A -83	4
S23341009	D -31	10
	F -98	20
S23342001	C -1-2	8
	C -7-1	8
	G -1-3	22
	H -9-1-1	24
S23346101	H -1-2	24
	J -1-2	26
S23349001	D -45	10
S23350001	A -63	4
S23351001	A -65	4
S23353001	Z -58	42
S23356001	Z -10	42
S23357001	A -79	4
S23360001	E -37	14
	E -42	14
S23364000	D -44	10
S23367001	A -16	2
S23418002	A -60	4
	C -21	8
	M -27	32
	P -2	34
	R -2-5	36
S23452002	M -22	32
S23453001	E -84	16
S23458101	E -7	14
S23460001	L -4-11	28
S23611101	H -15	24
S23612051	E -73	16
S23614101	J -12	26

CODE	REF.NO.	Page
S23615001	E - 5	14
S23616101	A - 25-2	2
	E - 82	16
S23619001	F - 12	18
	G - 6	22
	H - 6	24
S23621101	E - 72	16
	E - 76	16
	E - 78	16
	F - 103	20
	G - 16-1	22
S23626001	H - 7	24
	J - 6	26
S23628051	E - 71	16
S23651002	R - 2-1-18	36
	R - 5-11	40
S23773001	Q - 1-2	34
S23774001	R - 6-8	36
S23775001	R - 2-1-6	36
S23777101	R - 2-1-4	36
S23779001	R - 2-6	36
S23896101	Q - 1-1	34
S23897001	Q - 1-4	34
S25081001	Ga - 2	45
S25083001	D - 50-4-2	12
S25084001	Ga - 2	45
S25097001	Ga - 6	45
S25179001	A - 92	4
S25180001	A - 92	4
S25186001	Ga - 3	45
S25526000	L - 35	28
S25530001	B - 1-1	6
S25568101	Ga - 5	45
S25818051	E - 61	16
	F - 46	18
	F - 79	20
S25823001	Ga - 2	45
S25825001	Ga - 2	45
S25827001	Ga - 2	45
S25879001	L - 32	28
S27868001	B - 16	6
S28044009	F - 11	18
S29094001	E - 69	16
S29132001	F - 43	18
S29700000	H - 9-3	24
S29853109	Z - 42	44
S29933000	P - 5-3	34
S29934000	P - 5-4	34
S30137001	R - 6	36
S30400001	R - 7	40
S30401001	R - 2	36
S30402101	R - 3-1	38
S30402102	R - 3-2	38
S30403001	R - 7	40
S30404001	R - 5	40
S30405101	R - A	40
S30406101	R - A	40
S30517101	A - 73	4
S30562000	E - 18	14
S31111101	R - A	40
S31112101	R - A	40
S33024001	Ga - 3	45
S33026001	Ga - 5	45

CODE	REF.NO.	Page
S33027001	Ga - 5	45
S34326000	B - 23	6
S35997001	Z - 29	42
	Z - 64-3	44
S36007001	Z - 64-4	44
S37037001	Z - 42-16-3	44
	Z - 42-17-3	44
S37038001	Z - 42-16-2	44
S37060001	Wa	46
S37070121	D - 34	10
S38312050	E - 24	14
S38320100	H - 9-2-1	24
S38330050	M - 46	32
S38349001	Wa	46
S38350001	Wa	46
S38645001	Z - 65	42
S38648001	Z - 42-4-2	44
S39564021	A - 23	2
S39565101	B - 24	6
S39571021	C - 10	8
S39577000	D - 2-1	10
S39589021	E - 8	14
S39593021	E - 54	16
S39596021	E - 54-1	16
S39607001	A - 8	2
S39611001	A - 27	2
S39612001	A - 27-1	2
S39613001	A - 27-2	2
S39625151	A - 49	2
S39629021	B - 3	6
S39630000	B - 10	6
S39631000	B - 20	6
S39644021	C - 2	8
S39645021	C - 3	8
S39646021	C - 4	8
S39647000	C - 5	8
S39648021	C - 9	8
S39649021	C - 14	8
S39650051	C - 16	8
S39653051	C - 24	8
S39660001	D - 7	10
S39661001	D - 8	10
S39662001	D - 9	10
S39663021	D - 11	10
S39664001	D - 12	10
S39665001	D - 15	10
S39671101	D - 26	10
S39672001	D - 29	10
S39674001	E - 9	14
S39675001	E - 10	14
S39676121	E - 15	14
S39677021	E - 16	14
	F - 10	18
	G - 5	22
	H - 4	24
	J - 9	26
S39678021	E - 17	14
S39679001	E - 20	14
S39683000	E - 26	14
S39684021	E - 27	14
S39685001	E - 28	14
S39690021	E - 36	14
	E - 41	14

CODE	REF.NO.	Page
S39691001	E - 39	14
S39692021	E - 50	14
S39694021	E - 64	16
	F - 39	18
	F - 76	20
S39695001	E - 65	16
	F - 40	18
	F - 77	20
S39704021	G - 4	22
S39707001	G - 19	22
S39708001	G - 25	22
S39709021	G - 28	22
S39728021	F - 9	18
	H - 3	24
	J - 8	26
S39733001	D - 27	10
S39769051	E - 40	14
S39773001	E - 35	14
S40640001	Z - 42-7	44
S40641001	Z - 42-16	44
S40643001	Z - 42-17	44
S40644001	Z - 42-18	44
S42042021	E - 33	14
S43453001	A - 97	4
S43521000	L - 36-2	28
S43522000	L - 36-1	28
S43523000	L - 36	28
S43916001	E - 48	14
S44535001	A - 25-3	2
S44536000	A - 24	2
S44821001	A - 94	4
S46839000	D - 24	10
S46840001	D - 6	10
S46841001	D - 53	10
S46842001	D - 54	10
S46843001	D - 56	10
S46844001	F - 87	20
S46849001	D - 21	10
S46887001	D - 2	10
S46889001	D - 5	10
S46891001	E - 23	14
S46895001	E - 68	16
S46896001	H - 9	24
S46899001	C - 7-2	8
	D - 22	10
	H - 9-1-2	24
S46900001	B - 13	6
S46901001	H - 9	24
S46903001	D - 30	10
	H - 13	24
S46904001	J - 5	26
S46905001	L - 12	28
S46907001	Z - 11	42
S46908001	D - 5	10
S46923001	B - 1	6
S46931001	C - 1	8
S46932001	C - 1	8
S46933001	G - 1	22
S46940001	H - 1	24
S46941001	J - 1	26
S46942001	J - 1	26
S47031000	F - 22	18
S49337000	L - 28	28

CODE	REF.NO.	Page
004350812	E -31	14
011502012	D -47	10
012060632	B -25	6
	D -25	10
	E -2	14
	E -4	14
	E -73-1	16
	F -1-3	18
	F -7	18
	F -12-1	18
	F -20	18
	F -57	20
	F -93	20
	G -6-1	22
	H -6-1	24
	R -6-4	36
012400432	A -27-4	2
	A -32	2
	A -40-1	2
	D -28	10
	E -29	14
	F -25	18
	F -29	18
	F -63	20
	F -68	20
	F -82-2	20
	H -13	24
	R -6-12	36
012400536	L -4-2	28
012400632	A -42	2
	F -96	20
012400832	A -31	2
	E -32	14
012500532	L -2	28
014060632	Z -42-17-1	44
014780622	R -3-1-1-6	38
	R -3-1-1-19	38
	R -3-1-1-19	38
	R -3-2-1-6	38
017060812	H -8	24
	J -7	26
017061612	C -1-3-1	8
	G -1-2-1	22
017081606	R -3-1-1-8	38
	R -3-2-1-8	38
017085502	Z -64-5	44
017500812	G -26	22
017501212	A -64	4
017781012	R -3-1-1-4	38
	R -3-1-1-10	38
	R -3-1-1-13	38
	R -3-1-1-15	38
	R -3-1-1-15	38
	R -3-2-1-4	38
	R -3-2-1-10	38
	R -3-2-1-13	38
018061432	E -53	14
	H -10	24
	L -6	28
018061632	E -8-1	14
	E -34	14
	E -40-1	14
	E -60	16

CODE	REF.NO.	Page
018061632	F -31	18
	F -70	20
	F -86	20
018062532	B -28	6
	C -15	8
	D -13	10
018401032	R -2-3	36
018401622	C -1-1-1	8
	F -1-2	18
	G -1-1	22
	H -1-1	24
	J -1-1	26
018401632	R -2-2	36
021060302	R -2-1-20	36
	R -2-7	36
021080106	Z -33	42
	Z -64-8	44
021350106	F -51	18
021400106	Z -70	42
	Z -70	42
021400202	F -91	20
021400212	A -53	4
	Q -1-5	34
	R -2-1-22	36
	R -6-10	36
021500106	Z -42-10-3	44
	Z -42-16-1	44
	Z -42-17-2	44
	Z -42-18-1	44
021500303	R -6-7-1	36
021500312	D -48	10
025030132	G -14	22
025040132	A -45	2
	E -49	14
	G -11	22
	P -4	34
025040332	Z -60	42
025050132	A -72	4
025060236	F -37	18
	F -85	20
025060332	D -14	10
025080236	Z -64-6	44
025350332	A -68	4
	E -63	16
	R -5-5	40
025710132	F -106	18
025710232	E -12	14
	E -13	14
025770232	R -3-1-1-18	38
	R -3-1-1-18	38
028050246	Z -42-10-2	44
028060242	B -27	6
028080242	Z -32	42
	Z -64-7	44
031411304	Z -57	42
031452206	Z -42-18-2	44
032422505	R -3-1-5	38
	R -3-1-5	38
034422006	R -5-6-2	40
047250842	E -1-1	14
047301642	D -2-2	10
047401642	D -21-1	10
047502542	E -57	16

CODE	REF.NO.	Page
047602042	A -54	4
048040342	E -14	14
	E -70	16
	F -44	18
048090342	E -19	14
048400242	B -14	6
060300412	D -35	10
	M -30	32
	Z -92	42
060300512	Z -92	42
060300612	M -52	32
060350812	A -67	4
	E -62	16
	J -16	26
060351012	J -15	26
060400512	A -96	4
	L -17-1	28
060400612	A -12	2
	A -27-7	2
	A -27-9	2
	A -34	2
	A -36	2
	A -46	2
	A -50	2
	D -10	10
	E -22	14
	H -16	24
	M -24	32
	M -32	32
	M -36	32
	M -39	32
	M -41	32
	M -45	32
060400812	A -15	2
	A -17	2
	D -46	10
	F -75	20
	G -29	22
	L -11	28
	L -26	28
	L -33	28
	M -4	32
	M -20	32
	M -43	32
	Z -64-11	44
	Z -64-12	44
060401012	A -25-1	2
	A -47	2
	P -3	34
060401412	A -28	2
	F -89	20
060630412	D -50-1-5	12
060630712	E -75-1	16
061400812	A -18	2
	A -26	2
	A -58	4
	B -6	6
	L -23	28
062060812	G -18	22
	G -21	22
062061012	F -38	18
062061412	Z -66	42
062300412	G -16-2	22

CODE	REF.NO.	Page
062300512	F -16	18
	Q -1-7	34
062300812	R -2-1-11	36
062350512	R -2-1-27	36
062350612	D -37	10
	F -35	18
	F -48	18
	F -81	20
	Q -1-9	34
	R -5-4	40
062350812	C -7-3	8
	C -25	8
	R -6-5	36
062351016	L -4-8	28
062400612	A -30	2
	C -19	8
	L -44	30
	L -47	30
	L -58	30
	R -2-1-25	36
	Z -59	42
062400812	A -9	2
	B -5	6
	R -2-1-16	36
062401012	A -22	2
	B -22	6
	C -17	8
	E -6	14
	P -6	34
	Q -2	34
	R -3-1-6	38
	R -3-2-6	38
062401212	A -4	2
	A -52	4
	G -10-1	22
062401406	Z -71	42
	Z -71	42
062401612	A -81	4
	D -57	10
	G -10-2	22
	R -2-1-21	36
062501006	Z -42-18-3	44
062501212	F -88	20
062501406	Z -42-16-4	44
062670712	D -42	12
	D -50-1-4	12
	D -50-4-4	12
072600000	B -7	6
076203000	B -15	6
081005070	E -11	14
	F -94	20
081005670	E -56	16
	F -66	20
081008070	L -5	28
081009070	A -77	4
081020070	E -21	14
081031870	B -4	6
081044070	L -9	28
100032003	C -33	8
100136001	R -5-1-4	40
101118001	R -5-2	40
101572101	Z -5	42
102707002	F -74	20

CODE	REF.NO.	Page
102707002	R -2-8	36
104450101	C -11	8
105161004	D -3	10
	F -47	18
	F -80	20
108494001	R -5-1-2	40
108495001	R -5-1-3	40
110744002	R -3-1-1-17	38
	R -3-1-1-17	38
110832009	M -12	32
116016001	Z -72	42
	Z -72	42
117466000	Z -13	42
118735002	C -1-3-2	8
	G -1-2-2	22
118770001	A -44	2
122991001	Z -25	42
126863001	Z -42-3	44
138843001	Z -42-12	44
140530002	D -52	12
	D -52	12
142002001	Z -8	42
142262001	Z -24	42
142628001	E -25	14
142997001	Z -42-6	44
143767002	R -5-1	40
143980001	R -5-1-1	40
144074350	G -15-1	22
	Ga -7	45
144103009	M -13	32
144225002	Z -41	42
144784001	R -2-1-10	36
144875001	L -4-9	28
144876001	L -4-10	28
145277205	Z -19	42
146293001	C -6	8
146427001	C -12-1	8
	M -47	32
146532001	F -6	18
	F -19	18
	F -56	20
146592001	M -21	32
146598001	A -71	4
	Q -1-3	34
146762001	Q -1-8	34
147363000	L -48	30
147893009	Z -69	42
	Z -69	42
147919051	Z -48-1	42
147919052	Z -48-2	42
147942001	L -12-1	28
148084001	L -20	28
148294001	D -50-1-3	12
	D -50-4-3	12
148782001	J -13	26
148797001	R -3-1-1-5	38
	R -3-2-1-5	38
148798109	R -3-1-1-7	38
	R -3-2-1-7	38
149570001	Z -9	42
150173003	Z -42-9	44
150174000	Z -42-7-1	44
150179002	Z -42-10-1	44

CODE	REF.NO.	Page
150180001	Z -42-1	44
150182000	Z -42-2	44
150185009	Z -42-11	44
150188009	Z -42-13	44
150206002	Z -42-4-1	44
150307000	P -1-4	34
150755001	D -50-1-3	12
151474011	Ga -1	45
151474014	Ga -1	45
151951001	F -49	18
153318201	Z -64-2	44
154841001	A -78	4
155162001	C -7-6	8
	H -9-1-3	24
155197101	R -3-1-1-1	38
	R -3-2-1-1	38
155199101	R -3-1-1-3	38
	R -3-1-1-14	38
	R -3-1-1-14	38
	R -3-2-1-3	38
155247000	G -3	22
	H -11	24
	J -10	26
155539000	F -61	20
155559001	B -12	6
156112003	Z -42-8	44
156482000	A -51	2
158722002	D -55	10
	J -17	26
183797009	Z -56	42
183798001	Z -64	44
213650001	Z -31	42
	Z -64-9	44



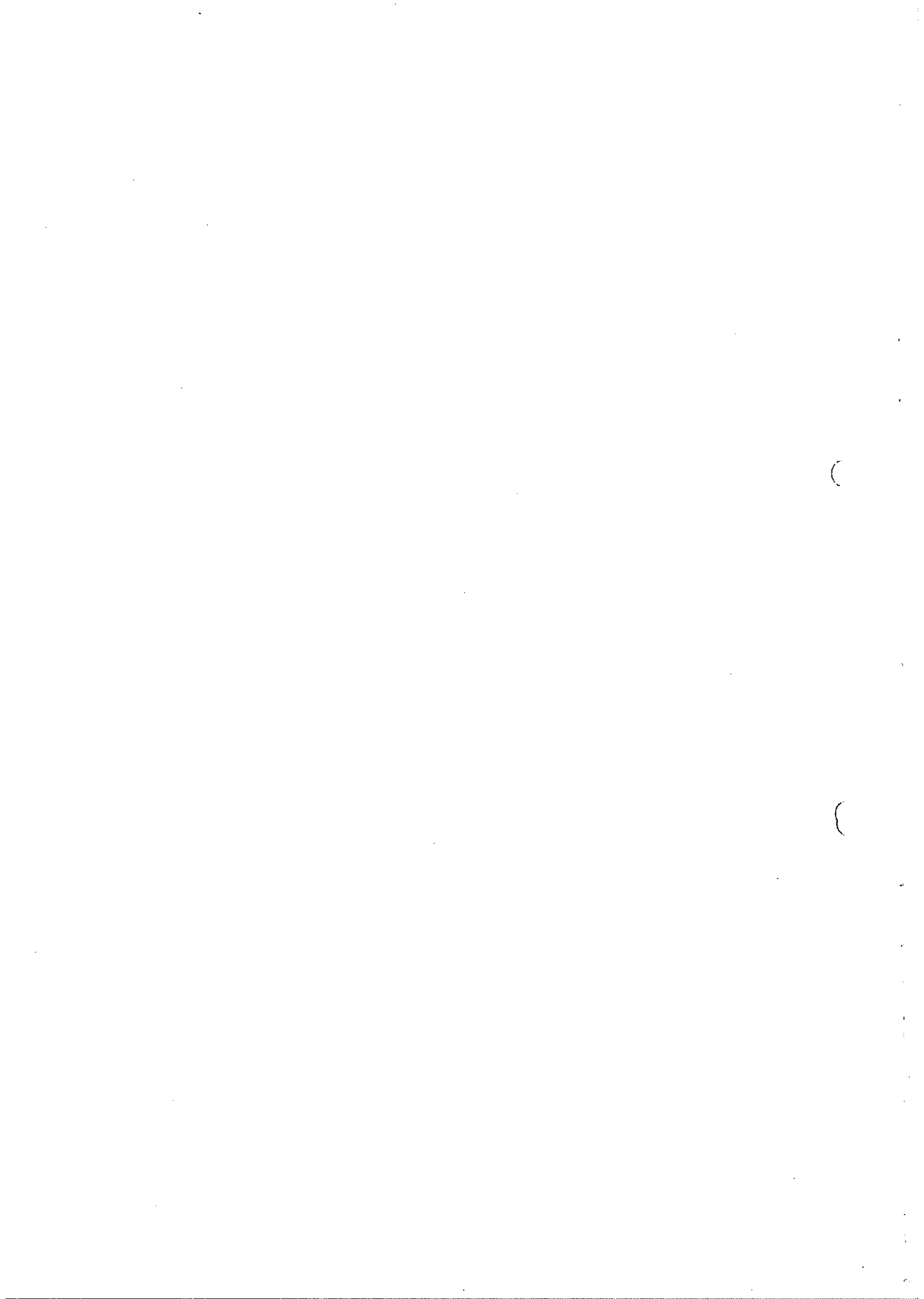

**brother**<sup>®</sup>

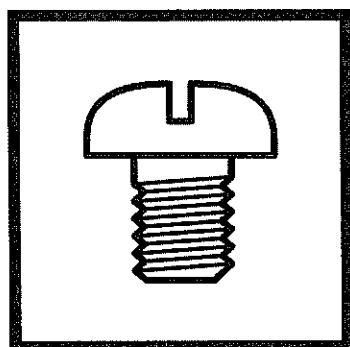

パーツブック  
PARTS BOOK

**ブラザー工業株式会社**

**BROTHER INDUSTRIES, LTD**

Printed in Japan

878-V7A,B  
S97V7A-101  
2002.03.C (1)