

DA-9270

パーツブック
PARTS BOOK

DA-9280

2本針・3本針二重環縫伏縫腕ミシン

TWIN NEEDLE/THREE NEEDLE FEED OF THE ARM DOUBLE CHAIN STITCHER

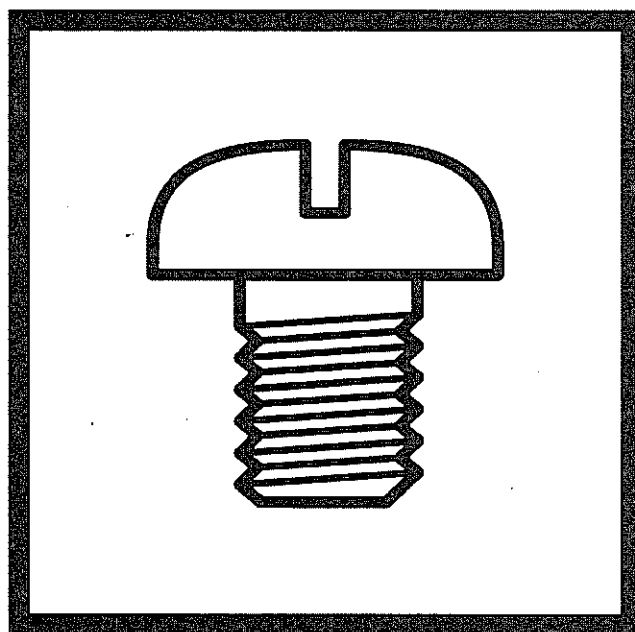

brother®

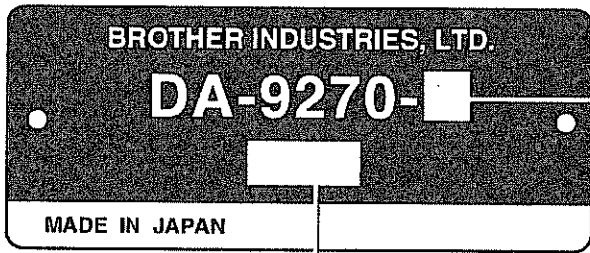

オプション装置 / Optional devices

- 1. 薄物 / Light materials
- 2. 薄物~中厚物 / Light - medium materials
- 3. 中厚物 / Medium materials
- 4. 薄物、プーラ付 / Light materials with puller

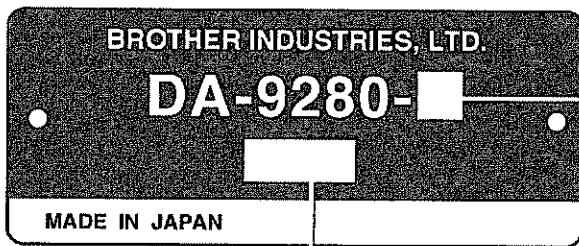

オプション装置 / Optional devices

- 5. 厚物 / Heavy materials
- 7. 極厚物 (デニム) / Extra heavy materials (denim)
- C. 厚物、プーラ付 / Heavy materials with puller
- D. 極厚物(デニム)プーラ付 / Extra heavy materials (denim) with puller

パーツブックご利用に際して

1. この本は、1996年12月のデータに基づいて作成されたものです。
2. 部品は予告なしに設計変更される場合があります。
3. 組単位で補給する部品は、[] 破線で示しております。
4. 部品コード欄が※となっている場合は、仕様別部品一覧表(55~59ページ)でお調べ下さい。

目 次

A. 主体関係	1	H. プーラ装置関係 (-A, -C, -D)	25
B. 上軸関係	1	J. 下軸関係	29
C. 針棒関係	3	K. ルーパー関係	31
D1. 押工棒関係 (9270)	3	L1. 上糸通シ関係 (9270)	33
D2. 押工棒関係 (9280)	5	L2. 上糸通シ関係 (9280)	37
E. プーリ関係	7	M1. 下糸通シ関係 (9270)	41
F. 送り関係	9	M2. 下糸通シ関係 (9280)	45
G1. ゲージ関係 (9270スタンダード)	11	Z1. 付属品関係	49
G2. ゲージ関係 (9270-A)	13	Z2. 付属品関係	51
G3. ゲージ関係 (9280スタンダード)	15	仕様別部品一覧表 (9270)	55
G4. ゲージ関係 (9280-5,-7 2本針)	17	仕様別部品一覧表 (9280)	57
G5. ゲージ関係 (9280-7 3本針)	19	オプション部品 (9280)	60
G6. ゲージ関係 (9280-C,-D 2本針)	21	警告ラベル	61
G7. ゲージ関係 (9280-C 3本針)	23	目 次	62

Notes for using this parts book

1. This book was prepared based on information available in December 1996.
2. Parts are subject to changes in design without prior notice.
3. Parts supplied as complete assemblies are circled by a dotted line [] .
4. If the symbol ※ is found in the "Parts No." column, refer to the DIFFERENT PARTS LIST on page 55 ~59.

CONTENTS

A . Machine body	1	J . Lower shaft mechanism	29
B . Upper shaft mechanism	1	K . Looper mechanism	31
C . Needle bar mechanism	3	L1 . Upper threading mechanism (9270)	33
D1 . Presser bar mechanism (9270)	3	L2 . Upper threading mechanism (9280)	37
D2 . Presser bar mechanism (9280)	5	M1 . Lower threading mechanism (9270)	1
E . Pulley mechanism	7	M2 . Lower threading mechanism (9280)	45
F . Feed mechanism	9	Z1 . Accessories	49
G1 . Gauge parts (9270 Standard)	11	Z2 . Accessories	51
G2 . Gauge parts (9270-A)	13	DIFFERENT PARTS LIST (9270)	55
G3 . Gauge parts (9280 Standard)	15	DIFFERENT PARTS LIST (9280)	57
G4 . Gauge parts (9280-5, -7 Twin needle)	17	OPTION PARTS LIST (9280)	60
G5 . Gauge parts (9280-7 Three needle)	19	Warning labels	61
G6 . Gauge parts (9280-C, -D Twin needle)	21	Index	62
G7 . Gauge parts (9280-C Three needle)	23		
H . Puller device mechanism (-A, -C, -D)	25		

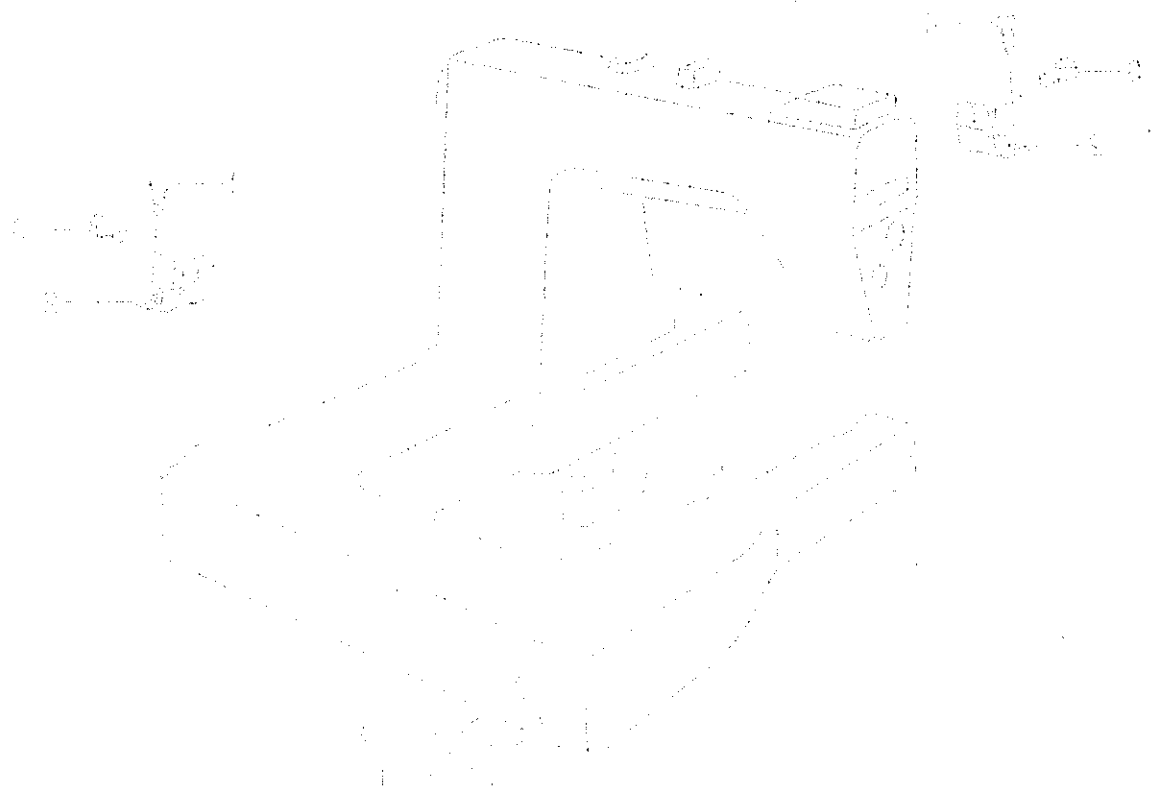

DD-ISA-8-1

FORM NO. 10 (REV. 10/2008)

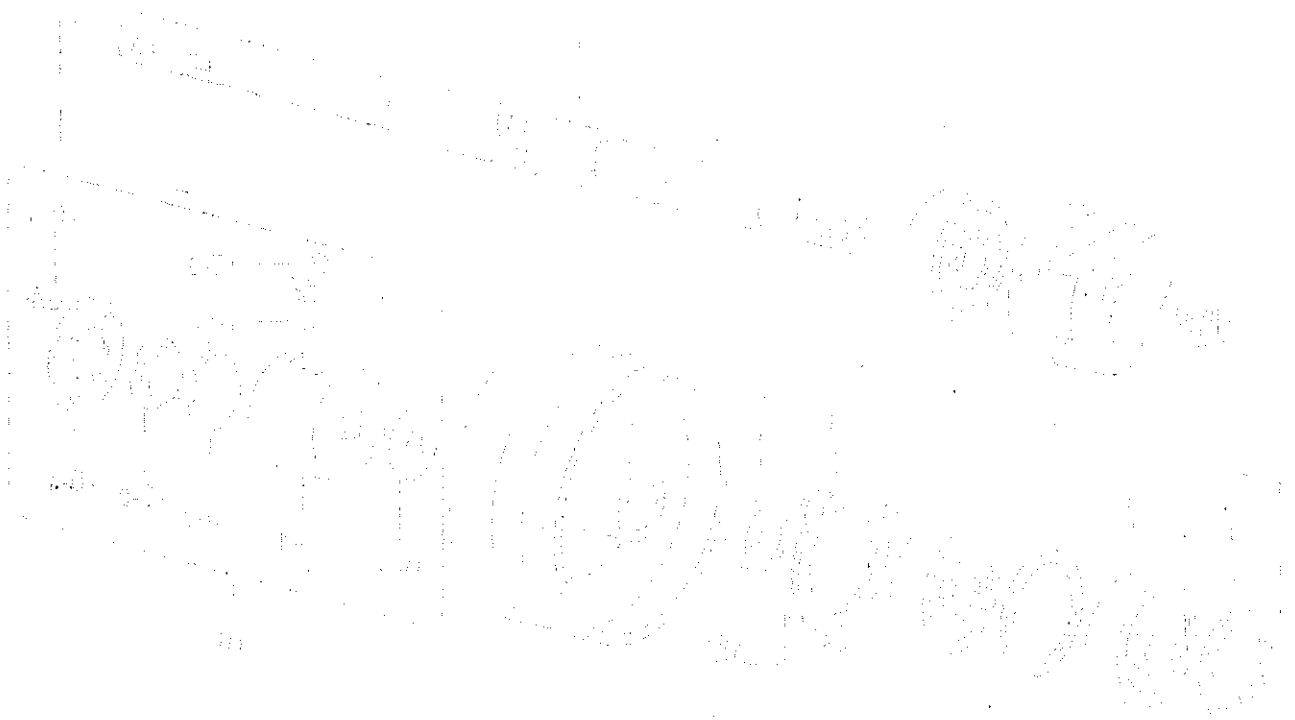

A. 主体関係 / Machine body

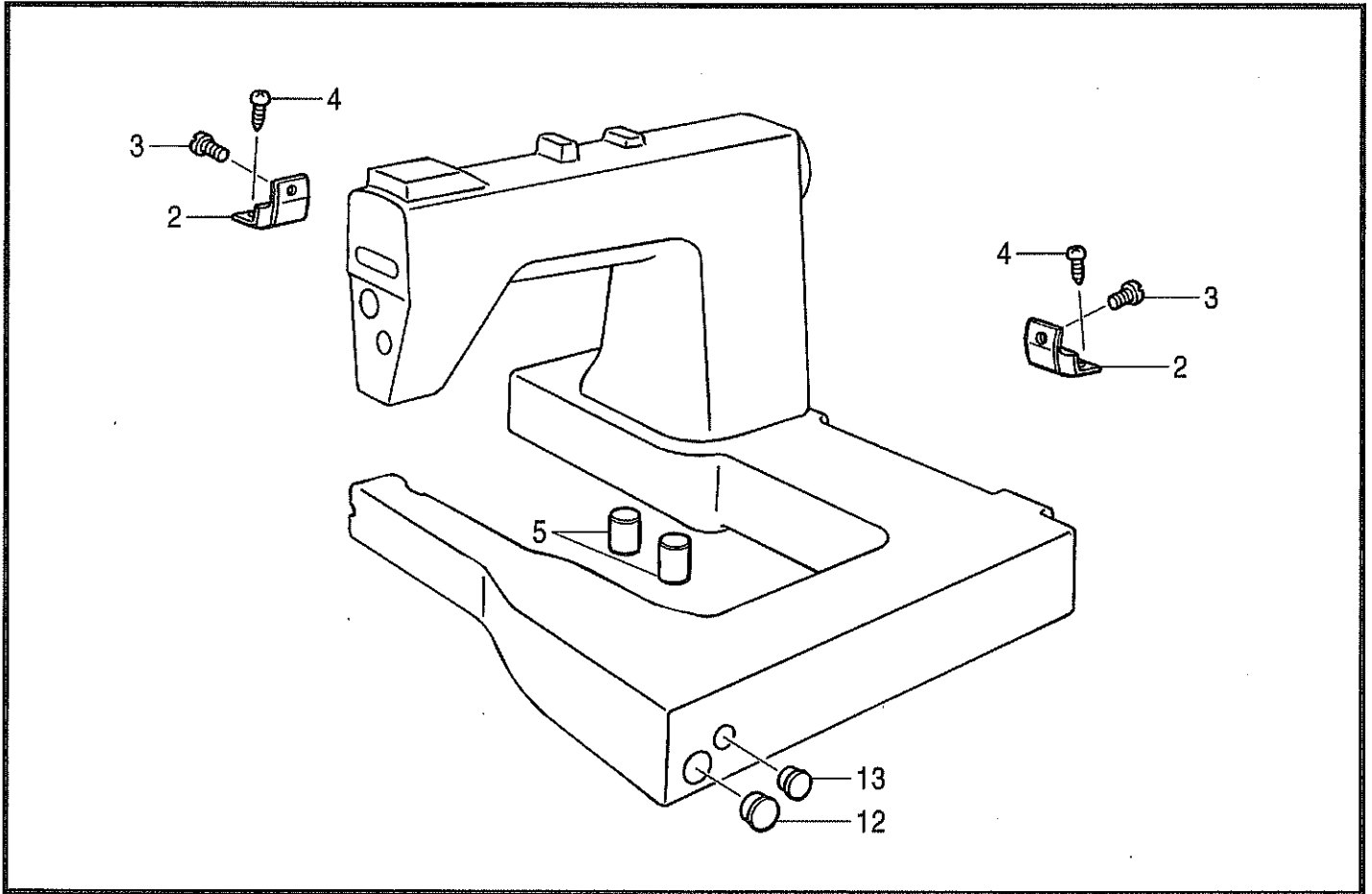

118-927-050

B. 上軸関係 / Upper shaft mechanism

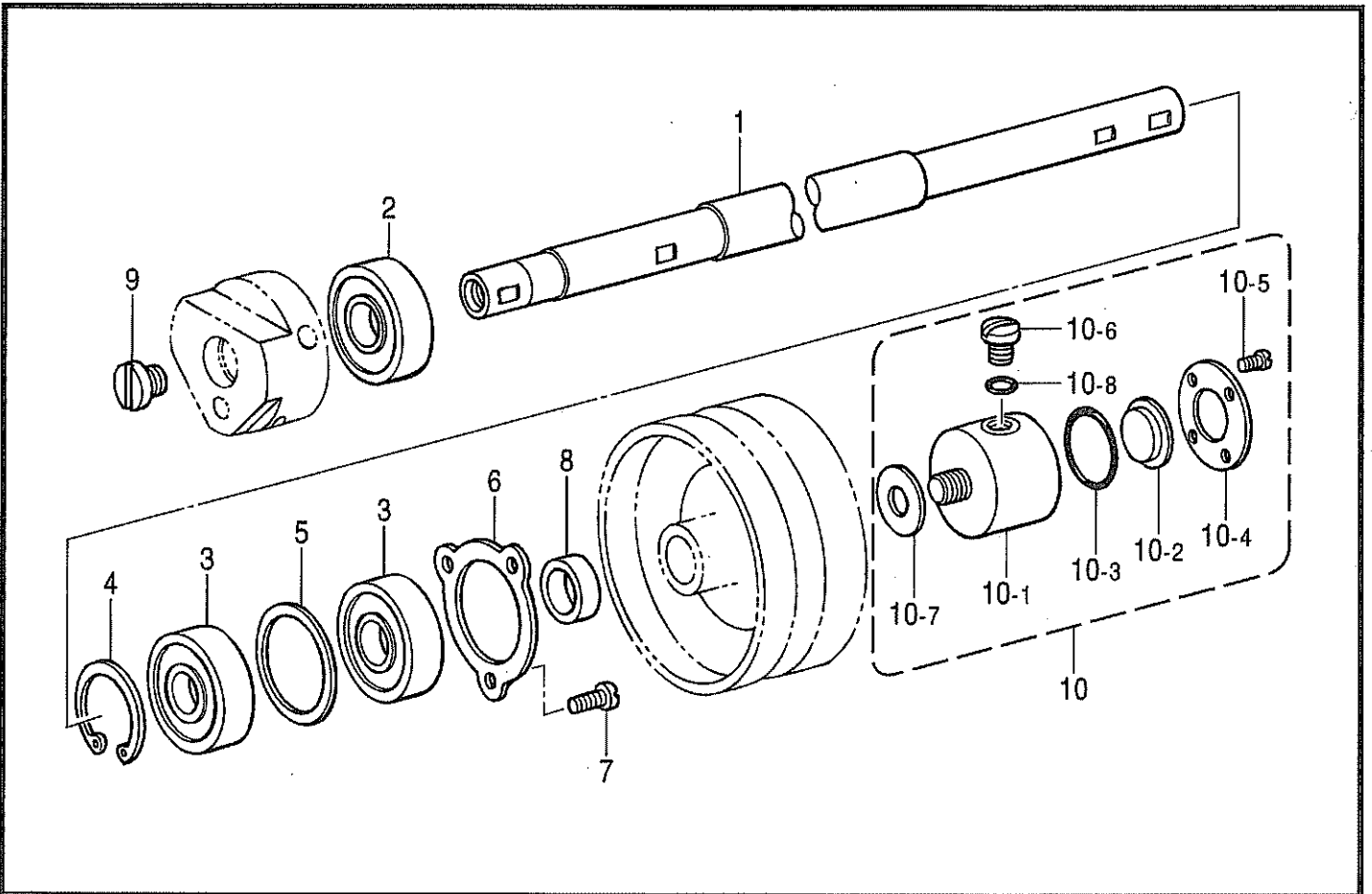

118-927-109

A. 主体関係 / Machine body

118-927-050

REF.NO.	CODE	Q'TY	ヒンメイ	NAME OF PARTS	RM
2	105337001	2	クツシヨクミ	CUSHION ASSY	
3	105146001	2	シメネジ6.35	SCREW, SM6.35	
4	0B0622502	2	+マルモク62X25	WOOD SCREW, ROUND M6.2X25	
5	105341051	2	ボウクツシヨク	BASE CUSHION	
12	150697001	1	オイルポツトマド	OIL GAUGE WINDOW	
13	104449009	1	ゴムセン15.5	RUBBER CAP, 15.5	

118-927-050

B. 上軸関係 / Upper shaft mechanism

118-927-109

REF.NO.	CODE	Q'TY	ヒンメイ	NAME OF PARTS	RM
1	S40314001	1	ウワジク	UPPER SHAFT	
2	076302850	1	タマジクウケ6302ZZ	BALL BEARING, 6302ZZ	
3	072630260	2	ベアリング6302VV	BALL BEARING, 6302VV	
4	048420242	1	トメワアナヨウC42	RETAINING RING, C42	
5	S40315051	1	ベアリングスペーサ	BEARING SPACER	
6	S40316051	1	ベアリングオサエ	BEARING PRESSER	
7	062711012	3	ナベコ476-32X10	SCREW, PAN SM4.76-32X10	
8	S40318051	1	ウワジクカラー	UPPER SHAFT COLLAR	
9	S40317001	1	シメネジ9.52	SCREW, SM9.52	
10	S40812001	1	オイルタンククミ	OIL TANK ASSY	
10-1	S40383001	1	オイルタンク	OIL TANK	
10-2	104547001	1	ユリヨウケイマド	OIL GAUGE WINDOW	
10-3	081014670	1	OリングPW14	O RING, PW14	
10-4	151074009	1	ユリヨウケイフタ	OIL GAUGE COVER	
10-5	100257010	4	シメネジ3.57	SCREW, SM3.57	
10-6	111193001	1	オイルクチフタ	OIL FEEDING PIPE CAP	
10-7	105071001	1	オイルタンクパツキン	OIL TANK PACKING	
10-8	111194001	1	Oリング	O RING	

118-927-109

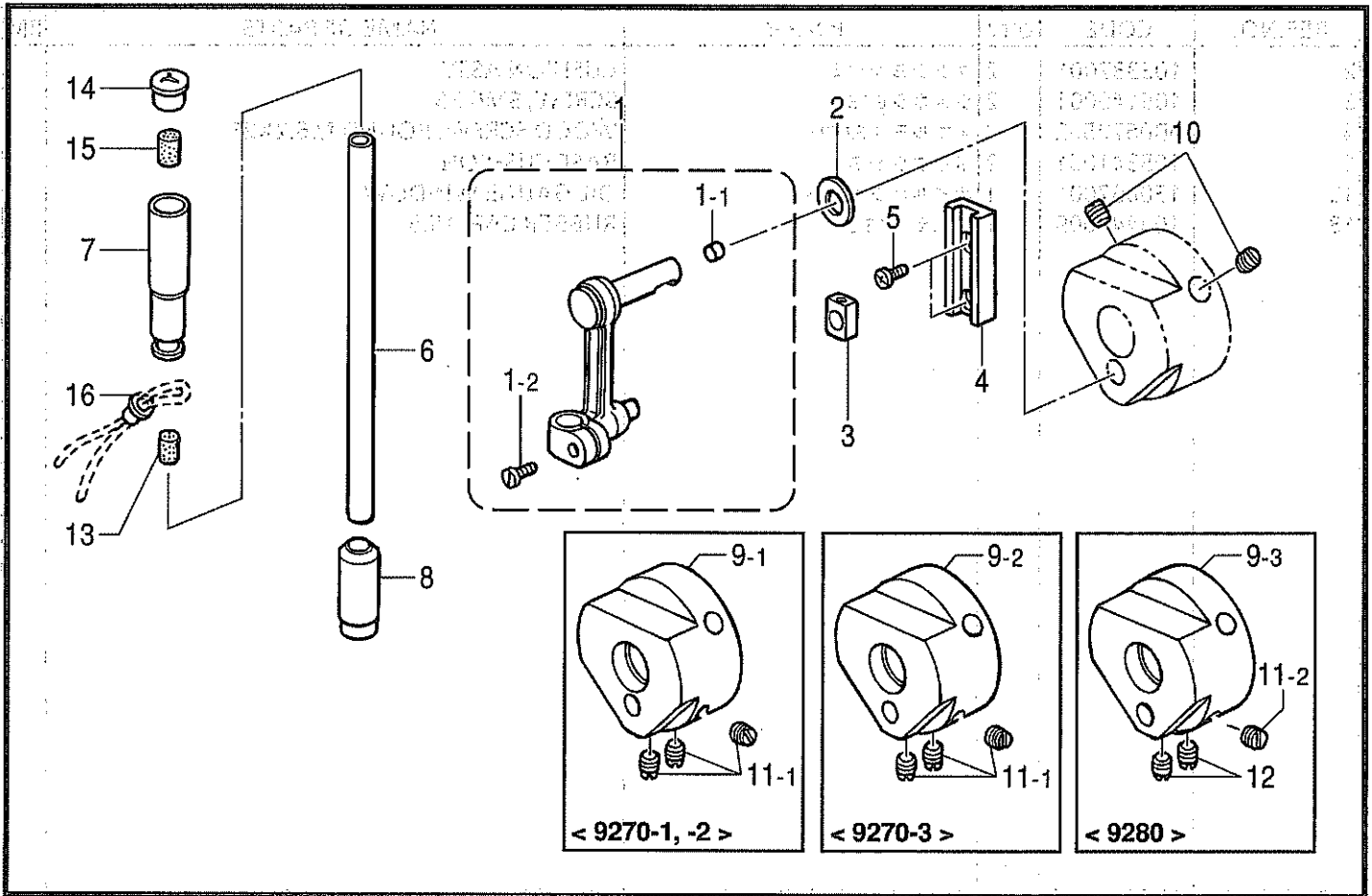

118-927-118

D1. 押工棒關係 (9270) / Presser bar mechanism (9270)

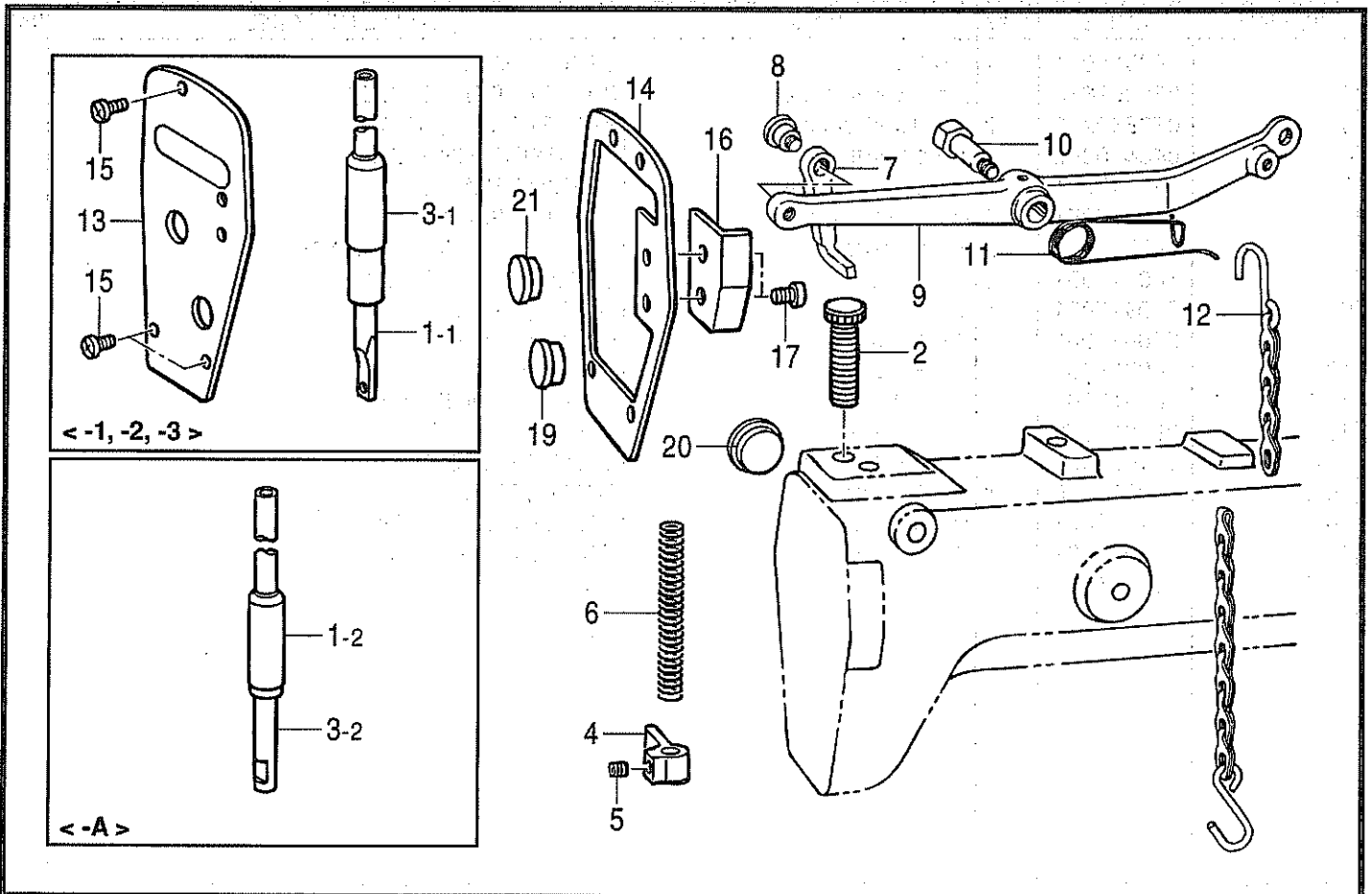

118-927-210

C. 針棒関係 / Needle bar mechanism

REF.NO.	CODE	Q'TY	ヒンメイ	NAME OF PARTS	RM
1	S40268001	1	ハリボウレンカクミ	THREAD TAKE-UP LEVER ASSY	
1-1	142274009	1	ゴムセン4.2	RUBBER CAP, 4.2	
1-2	140004001	1	シメネジ3.57	SCREW, SM3.57	
2	107153001	1	ザガネ	WASHER	
3	102630001	1	ハリボウアンナイカクコマ	NEEDLE BAR GUIDE SLIDE BLOCK	
4	145688000	1	ハリボウアンナイ	NEEDLE BAR GUIDE	
5	062670612	2	ナベコ357-40X6	SCREW, PAN SM3.57-40X6	
6	113605051	1	ハリボウ	NEEDLE BAR	
7	S18874001	1	ハリボウメタルU	NEEDLE BAR BUSH, U	
8	111024101	1	ハリボウメタルD	NEEDLE BAR BUSH, D	
10	014771022	2	アナトメネジ6.35クボミ	SET SCREW, SOCKET (CP) SM6.35	
13	111863001	1	ハリボウセン	NEEDLE BAR CORK	
14	140890009	1	オイルカッブ	OIL CAP	
15	151927001	1	クラッチフェルト	CLUTCH FELT	
16	109993001	1	ハトメ	WICK NIPPER	

9-1	S40271051	1	<9270-1, -2用> テンビンクランクM	<FOR 9270-1 & -2> THREAD TAKE-UP CRANK, M	
11-1	100251001	3	トメネジ6.35	SET SCREW, SM6.35	
9-2	S40272051	1	<9270-3用> テンビンクランクMH	<FOR 9270-3> THREAD TAKE-UP CRANK, MH	
11-1	100251001	3	トメネジ6.35	SET SCREW, SM6.35	
9-3	S40273051	1	<9280用> テンビンクランクH	<FOR 9280> THREAD TAKE-UP CRANK, H	
11-2	100251001	1	トメネジ6.35	SET SCREW, SM6.35	
12	123006001	2	トメネジ6.35クボミ	SET SCREW, (CP) SM6.35	

118-927-118

D1. 押工棒関係 (9270) / Presser bar mechanism (9270)

REF.NO.	CODE	Q'TY	ヒンメイ	NAME OF PARTS	RM
2	S40299001	1	オサエチヨウセツネジ	ADJUST SCREW	
4	S40798050	1	オサエボウダキ	PRESSER BAR CLAMP	
5	014760622	1	アナトメネジ5.95	SET SCREW, SOCKET SM5.95	
6	S40298051	1	オサエバネ	SPRING	
7	105103001	1	オサエボウアゲ	PRESSER BAR LIFTER	
8	105104001	1	ダンネジ5.95	SHOULDER SCREW, SM5.95	
9	105105009	1	ヒザアゲテコ	KNEE LIFTER LEVER	
10	102921002	1	ダンネジ7.94	SHOULDER SCREW, SM7.94	
11	105106001	1	ヒザアゲネジリバネ	TWIST SPRING	
12	105333001	1	クサリアクミ	PRESSER FOOT LIFTER CHAIN ASSY	
14	S40301001	1	メンイタバツキン	PACKING	
16	S40279001	1	ソクメンイタ	FRONT LID	
17	062680512	2	ナベコ437-40X5	SCREW, PAN SM4.37-40X5	
19	117934009	1	ゴムセン13.5	RUBBER CAP, 13.5	
20	159150009	1	ゴムセン20.5	RUBBER CAP, 20.5	
21	159150009	1	ゴムセン20.5	RUBBER CAP, 20.5	

1-1	S06259001	1	<-1, -2, -3用> オサエボウ	<FOR -1, -2 & -3> PRESSER BAR	
3-1	111025001	1	オサエボウメタルD	PRESSER BAR BUSH, D	
13	S40300001	1	メンイタ	FACE PLATE	
15	062681012	3	ナベコ437-40X10	SCREW, PAN SM4.37-40X10	
1-2	S06261001	1	<-A用> オサエボウ	<FOR -A> PRESSER BAR	
3-2	150665001	1	オサエボウメタルD	PRESSER BAR BUSH, D	

118-927-210

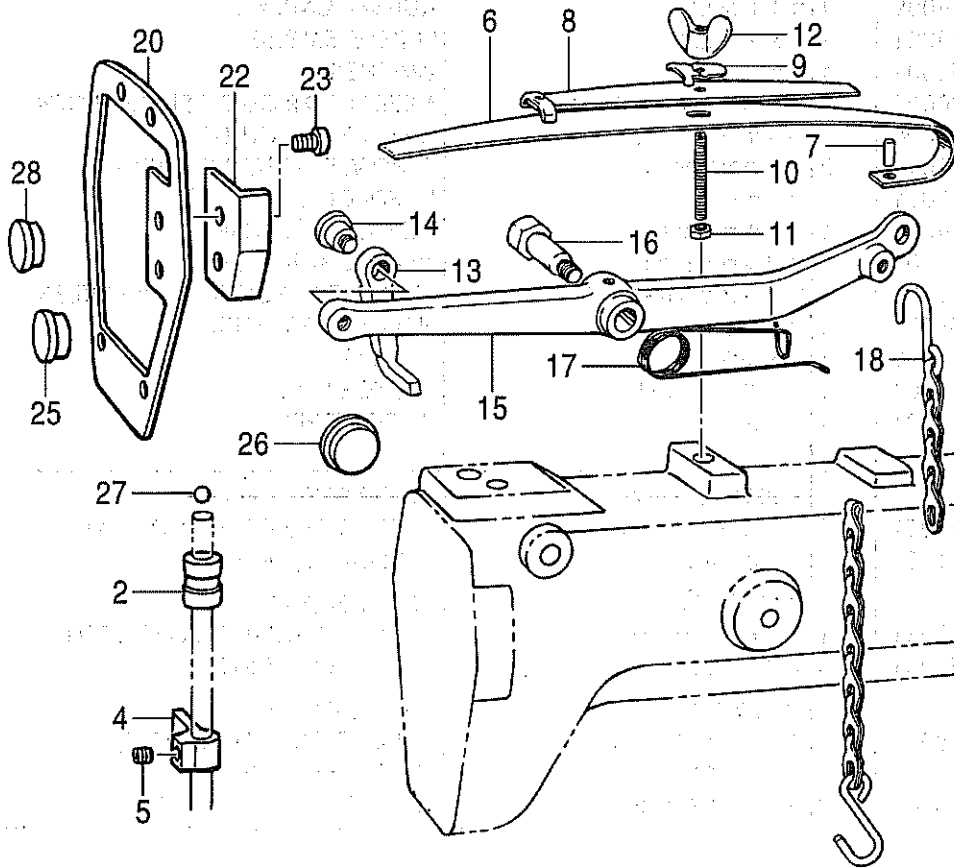

" オプション部品 / OPTION PARTS "

<-5, -7>

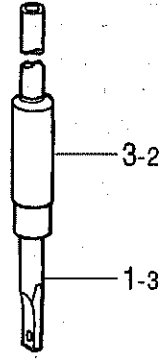
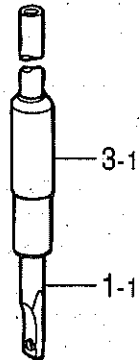

<-C, -D>

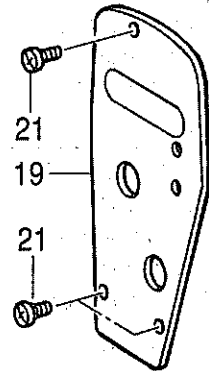
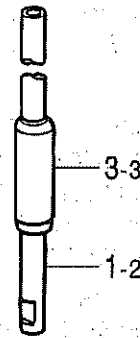

D2 . 押工棒関係 (9280) / Presser bar mechanism (9280)

REF.NO.	CODE	Q'TY	ヒンメイ	NAME OF PARTS	RM
2	105091001	1	オサエボウメタルU	PRESSER BAR BUSH, U	
4	S40798050	1	オサエボウダキ	PRESSER BAR CLAMP	
5	014760622	1	アナトメネジ5.95	SET SCREW, SOCKET SM5.95	
6	105094009	1	オサエイタバネ	PRESSER PLATE SPRING	
7	105095001	1	オサエイタバネピン	PIN	
8	105096009	1	カサネイタバネクミ	PLATE SPRING ASSY	
9	105100001	1	カサネイタバネトメザガネ	WASHER	
10	148006001	1	オサエチヨウセツネジ	ADJUST SCREW	
11	021710212	1	ナツト2シユ4.76	NUT, 2 SM4.76	
12	148007051	1	チヨウナツト4.76	WING NUT, SM4.76	
13	105103001	1	オサエボウアゲ	PRESSER BAR LIFTER	
14	105104001	1	ダンネジ5.95	SHOULDER SCREW, SM5.95	
15	105105009	1	ヒザアゲテコ	KNEE LIFTER LEVER	
16	102921002	1	ダンネジ7.94	SHOULDER SCREW, SM7.94	
17	105106001	1	ヒザアゲネジリバネ	TWIST SPRING	
18	105333001	1	クサリアクミ	PRESSER FOOT LIFTER CHAIN ASSY	
20	S40301001	1	メンイタバツキン	PACKING	
22	S40279001	1	ソクメンイタ	FRONT LID	
23	062680512	2	ナベコ437-40X5	SCREW, PAN SM4.37-40X5	
25	117934009	1	ゴムセン13.5	RUBBER CAP, 13.5	
26	159150009	1	ゴムセン20.5	RUBBER CAP, 20.5	
27	071063550	1	コウキユウ1/4	BEARING BALL, 1/4	
28	159150009	1	ゴムセン20.5	RUBBER CAP, 20.5	
<hr/>					
1-3	S06260001	1	<5, -7用> オサエボウ	<FOR -5 & -7> PRESSER BAR	
3-2	147865001	1	オサエボウメタルD	PRESSER BAR BUSH, D	
19	S40300001	1	メンイタ	FACE PLATE	
21	062681012	3	ナベコ437-40X10	SCREW, PAN SM4.37-40X10	
1-2	S06261001	1	<-C, -D用> オサエボウ	<FOR -C, -D> PRESSER BAR	
3-3	150665001	1	オサエボウメタルD	PRESSER BAR BUSH, D	
<hr/>					
1-1	S06259001	1	" オプション部品 " オサエボウ	" OPTION PARTS " PRESSER BAR	
3-1	111025001	1	オサエボウメタルD	PRESSER BAR BUSH, D	

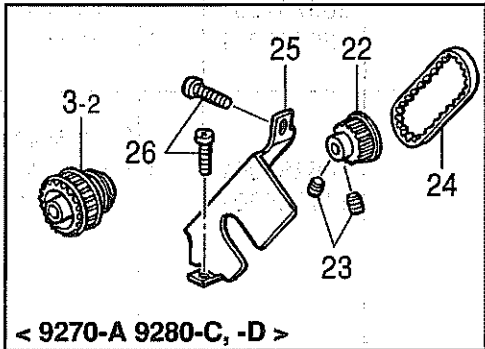
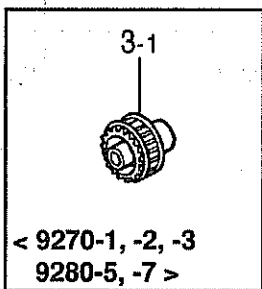
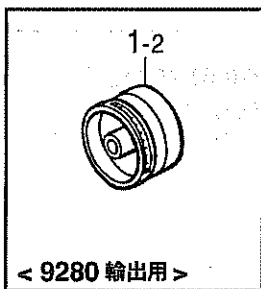
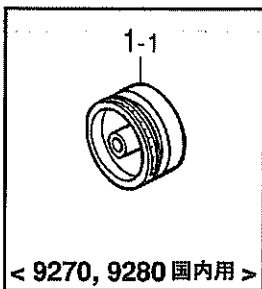
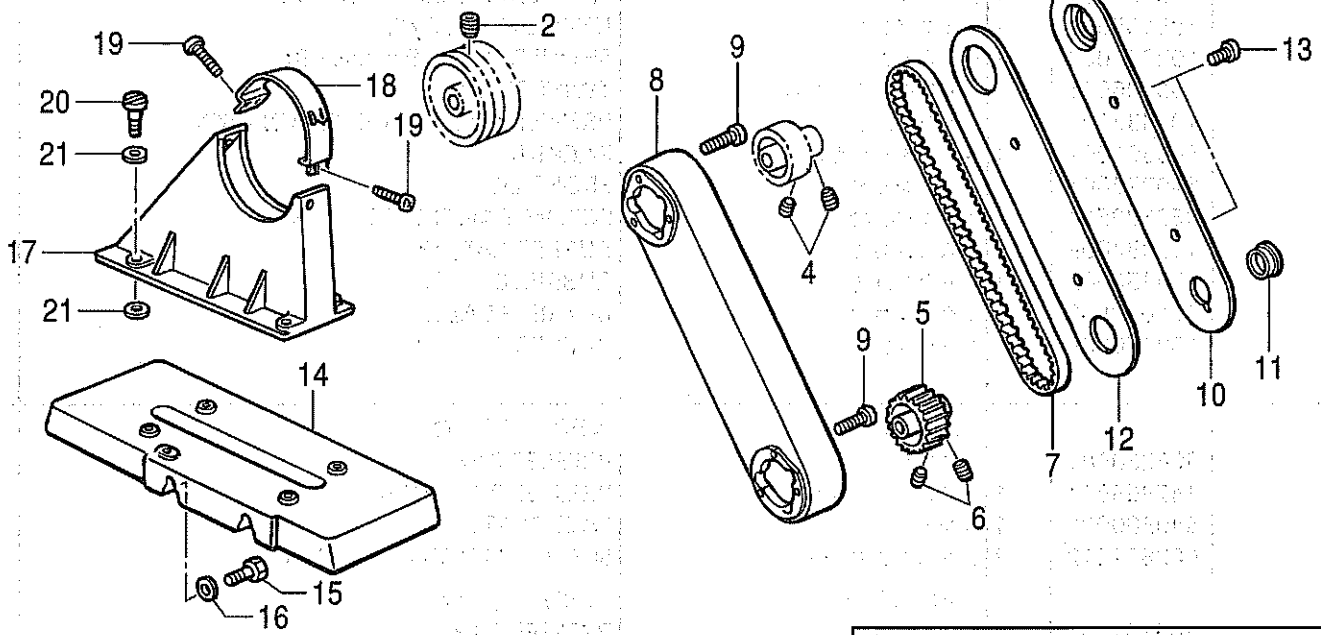

E. プーリ関係 / Pulley mechanism

REF.NO.	CODE	Q'TY	ヒンメイ	NAME OF PARTS	RM
2	014781032	2	アナクボミ 635-28X10	SET SCREW, SOCKET (CP) SM6.35	
4	014770622	2	アナトメネジ 6.35クボミ	SET SCREW, SOCKET (CP) SM6.35	
5	S40818001	1	シタベルトクルマ	TIMING BELT WHEEL ASSY, LOWER	
6	014770622	2	アナトメネジ 6.35クボミ	SET SCREW, SOCKET (CP) SM6.35	
7	S40819000	1	タイミングベルト	TIMING BELT	
8	S40258001	1	ベルトカバー	BELT COVER	
9	062711612	6	ナベコ 476-32X16	SCREW, PAN SM4.76-32X16	
10	S40259001	1	ベルトカバーフタ	BELT COVER PLATE	
11	116577051	1	カマジクフタ	ROTARY HOOK SHAFT COVER	
12	105141001	1	ベルトカバーフタパツキン	PACKING	
13	062710812	2	ナベコ 476-32X8	SCREW, PAN SM4.76-32X8	
14	S40796001	1	プーリカバーダイ	PULLEY COVER BASE	
15	105144001	2	ボルト 11.11	BOLT, SM11.11	
16	142627001	2	ザガネ	WASHER	
17	S40261001	1	プーリカバー-A	PULLEY COVER, A	
18	S40262001	1	プーリカバー-B	PULLEY COVER, B	
19	062680712	3	ナベコ 437-40X7	SCREW, PAN SM4.37-40X7	
20	155558001	4	ダンネジ 6.35	STUD SCREW, SM6.35	
21	S40797000	8	プーリカバーシート	PULLEY COVER SHEET	
1-1	S40280001	1	<9270用, 9280国内用> プーリMクミ	<FOR 9270 & 9280 Japan> PULLEY ASSY, M	
1-2	S40281001	1	<9280輸出用> プーリHクミ	<FOR 9280 EXPORT> PULLEY ASSY, H	
3-1	S40265001	1	<9270-1, -2, -3, 9280-5, -7用> ウエベルトクルマクミ	<FOR 9270-1, -2, 3, 9280-5 & -7> TIMING BELT WHEEL ASSY, UPPER	
3-2	S41312001	1	<9270-A, 9289-C, -D用> プーラウエベルトクルマクミ	<FOR 9270-A, 9280-C & -D> PULLER TIMING BELT WH. ASSY, U	
22	150659001	1	タイミングプーリBクミ	TIMING PULLEY ASSY, B	
23	014760622	2	アナトメネジ 5.95	SET SCREW, SOCKET SM5.95	
24	150661001	1	プーラタイミングベルトA	PULLER TIMING BELT, A	
25	S40264001	1	プーラベルトカバー	PULLEY BELT COVER	
26	062680812	2	ナベコ 437-40X8	SCREW, PAN SM4.37-40X8	

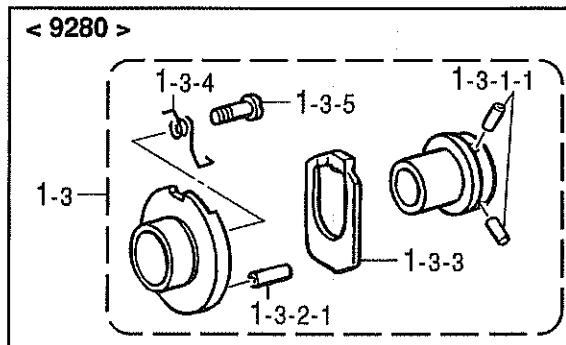
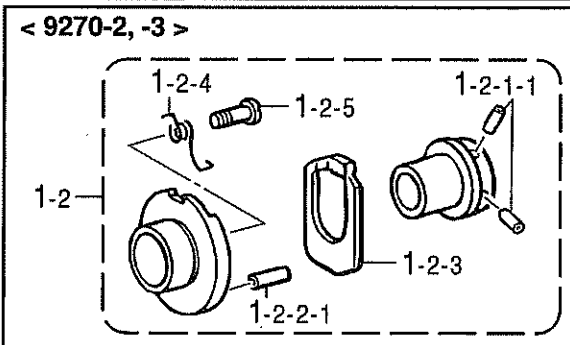
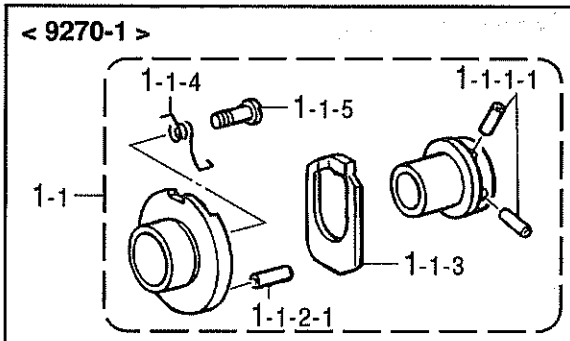
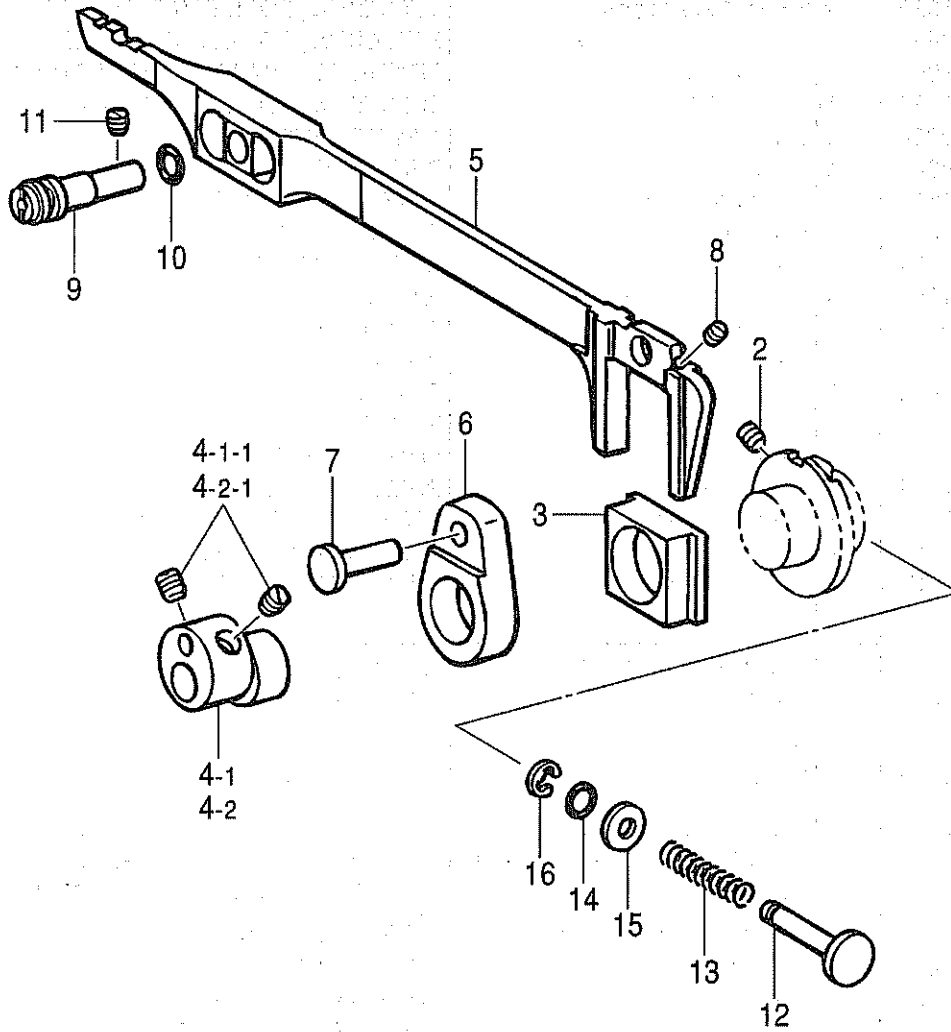

F. 送り関係 / Feed mechanism

REF.NO.	CODE	Q'TY	品名	NAME OF PARTS	RM
1-1	S40274001	1	<9270-1用> ヘンシンリンクミM	<FOR 9270-1> ECCENTRIC WHEEL ASSY, M	
1-1-1-1	047301242	2	スプリングピンAW3	PIN, SPRING AW3	
1-1-2-1	047301242	1	スプリングピンAW3	PIN, SPRING AW3	
1-1-3	S38309001	1	ラチェットストツパ	RACHTER STOPPER	
1-1-4	S39585001	1	ラチェットトメネジリバネ	TWIST SPRING	
1-1-5	S39586001	1	バネトメネジ3	SCREW, M3	
1-2	S40274002	1	<9270-2, -3用> ヘンシンリンクミM	<FOR 9270-2 & -3> ECCENTRIC WHEEL ASSY, M	
1-2-1-1	047301242	2	スプリングピンAW3	PIN, SPRING AW3	
1-2-2-1	047301242	1	スプリングピンAW3	PIN, SPRING AW3	
1-2-3	S38309001	1	ラチェットストツパ	RACHTER STOPPER	
1-2-4	S39585001	1	ラチェットトメネジリバネ	TWIST SPRING	
1-2-5	S39586001	1	バネトメネジ3	SCREW, M3	
1-3	S40291001	1	<9280用> ヘンシンリンクミH	<FOR 9280> ECCENTRIC WHEEL ASSY, H	
1-3-1-1	047301242	2	スプリングピンAW3	PIN, SPRING AW3	
1-3-2-1	047301242	1	スプリングピンAW3	PIN, SPRING AW3	
1-3-3	S38309001	1	ラチェットストツパ	RACHTER STOPPER	
1-3-4	S39585001	1	ラチェットトメネジリバネ	TWIST SPRING	
1-3-5	S39586001	1	バネトメネジ3	SCREW, M3	
4-1	183949001	1	<9270用> ヘンシンリンネジツキM	<FOR 9270> ECCENTRIC WHEEL WITH SCREW, M	
4-1-1	014770622	2	アナトメネジ6.35クボミ	SET SCREW, SOCKET (CP) SM6.35	
4-2	183950001	1	<9280用> ヘンシンリンネジツキH	<FOR 9280> ECCENTRIC WHEEL WITH SCREW, H	
4-2-1	014770622	2	アナトメネジ6.35クボミ	SET SCREW, SOCKET (CP) SM6.35	
2	012060632	2	アナヒラ6X6	SET SCREW, SOCKET (FT) M6X6	
3	S40282000	1	ヘンシンリンスリーブ	ECCENTRIC WHEEL SLEEVE	
5	S40285001	1	オクリダイカクコマクミ	FEED BAR SLIDE BLOCK ASSY	
6	S40288000	1	ジヨウゲオクリレンカン	FEED LIFTING CONNECTING SHAFT	
7	S40289051	1	ジヨウゲオクリジク	FEED LIFTING ROCK SHAFT	
8	014760622	1	アナトメネジ5.95	SET SCREW, SOCKET SM5.95	
9	S41311051	1	オクリダイヘンシンジク	FEED BAR ECCENTRIC SHAFT	
10	081006070	1	リングP6	O RING, P6	
11	014761030	1	アナクボミ595-28X10	SET SCREW, SOCKET (CP) SM5.95	
12	S40290051	1	プツシユボタン	PUSH BUTTON	
13	S40800001	1	ボタンジクバネ	SPRING	
14	081005070	1	リングP5	O RING, P5	
15	025710132	1	ヒラザガネシヨウ4.76	WASHER, PLAIN S 4.76	
16	048040342	1	トメワE4	RETAINING RING, E4	

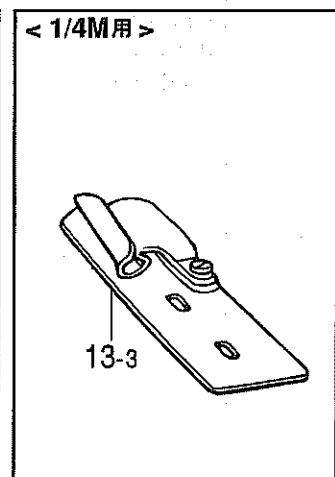
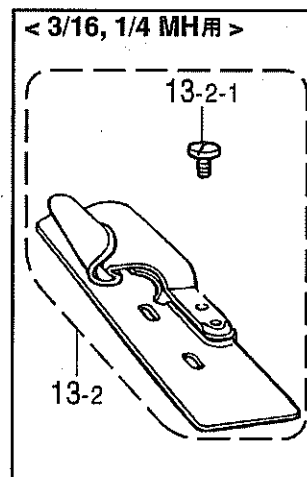
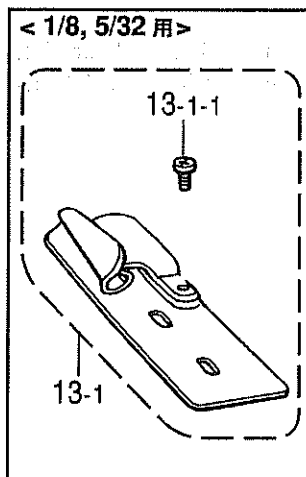
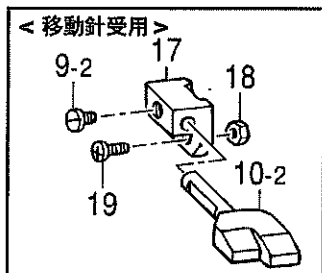
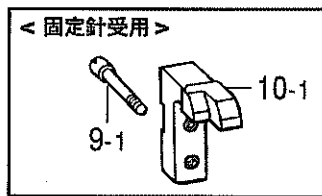
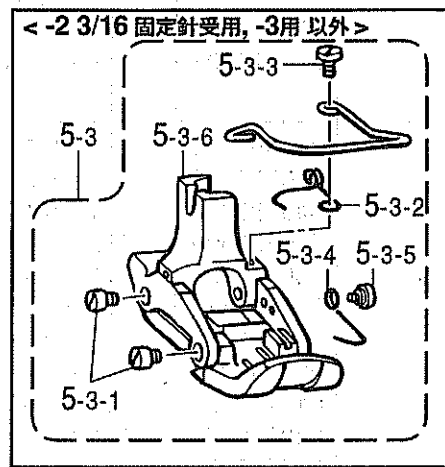
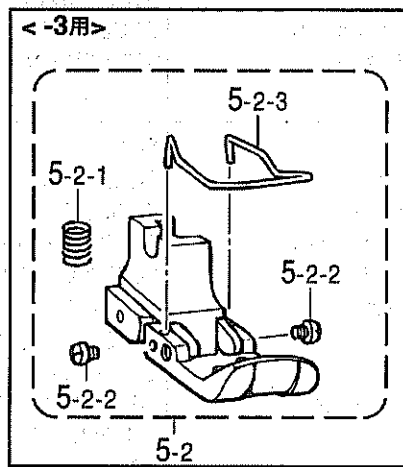
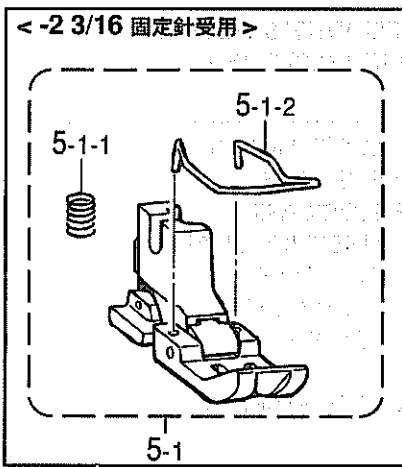
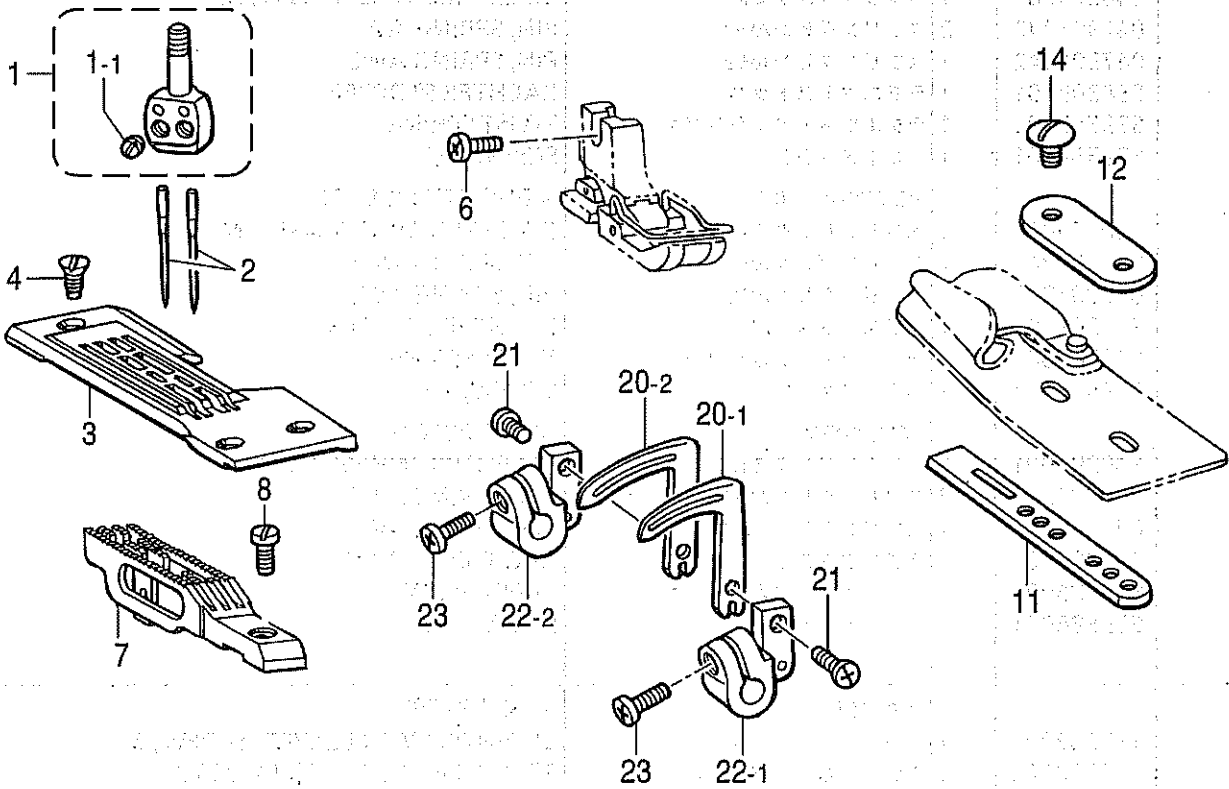

G1. ゲージ関係 (9270スタンダード) / Gauge parts (9270 Standard)

REF.NO.	CODE	Q'TY	ヒンメイ	NAME OF PARTS	RM
1	※	1	ハリダキネジツキ	NEEDLE CALMP ASSY W/S	
1-1	103408002	2	トメネジ4.37	SET SCREW, SM4.37	
2	※	2	ミシンハリ	NEEDLE	
3	※	1	ハリイタ	NEEDLE PLATE	
4	100032004	3	サラネジ4.37	SCREW, FLAT SM4.37	
6	060670812	1	バインド357-40X8	SCREW, BIND SM3.57-40X8	
7	※	1	オクリバ	FEED DOG	
8	105173004	1	シメネジ4.76	SCREW, SM4.76	
11	S40399001	1	ラツパーアンナイイタ	LAPPER GUIDE PLATE	
12	105129001	1	アンナイイタザガネ	LAPPER GUIDE PLATE WASHER	
14	105130001	2	シメネジ3.57	SCREW, SM3.57	
20-1	※	1	ルーパス	LOPPER, S	
20-2	※	1	ルーパL	LOPPER, L	
21	062680612	2	ナベコ4.37-40X6	SCREW, PAN SM4.37-40X6	
22-1	S06315001	1	ルーパホルダS	LOOPER HOLDER, S	
22-2	S06314001	1	ルーパホルダL	LOOPER HOLDER, L	
23	062681012	2	ナベコ437-40X10	SCREW, PAN SM4.37-40X10	
<hr/>					
5-1	101491101	1	<-2 3/16固定針受用> オサエ3/16クミ	<FOR -2, 3/16"Fix needle support"> PRESSER FOOT ASSY, 3/16"	
5-1-1	105118000	1	オシバネ	SPRING	
5-1-2	156792001	1	フィンガーガード	FINGER GUARD	
5-2	106160101	1	<-3用> オサエ1/4Hクミ	<FOR -3> PRESSER FOOT ASSY, 1/4" H	
5-2-1	105118000	1	オシバネ	SPRING	
5-2-2	111140001	2	シメネジ2.38	SCREW, SM2.38	
5-2-3	156792001	1	フィンガーガード	FINGER GUARD	
5-3	※	1	<-2 3/16固定針受用, -3以外用> オサエクミ	<FOR WITHOUT -2, 3/16, 1/4> PRESSER FOOT ASSY	
5-3-1	147871001	4	オサエピン	PIN	
5-3-2	S40358001	1	オサエMバネ	SPRING	
5-3-3	111105002	1	シメネジ2.38	SCREW, SM2.38	
5-3-4	S40360001	1	オサエFバネ	SPRING	
5-3-5	147932001	1	ダンネジ2.38	SHOULDER SCREW, SM2.38	
5-3-6	S40374001	1	フィンガーガード	FINGER GUARD	
<hr/>					
9-1	105303001	1	<固定針受用> シメネジ3.57	<FOR FIXED NEEDLE GUARD> SCREW, SM3.57	
10-1	※	1	ルーバイトアンナイウデ	LOOPER THREAD GUIDE ARM	
9-2	111443003	1	<移動針受用> マルヒラトメネジ3.57	<FOR MOVEABLE NEEDLE GUARD> SET SCREW, SM3.57	
10-2	※	1	ハリウケ	NEEDLE GUARD	
17	148876001	1	ハリウケトリツケダイ	NEEDLE GUARD BRACKET	
18	021670102	1	ナツト1シユ3.57	NUT, 1 SM3.57	
19	062671012	1	ナベコ357-40X10	SCREW, PAN SM3.57-40X10	
<hr/>					
13-1	※	1	<1/8, 5/32用> ラツパークミ	<FOR "1/8, 5/32"> LAPPER ASSY	
13-1-1	062670412	1	ナベコ357-40X4	SCREW, PAN SM3.57-40X4	
13-2	※	1	<3/16, 1/4MH用> ラツパークミ	<FOR "3/16, 1/4MH"> LAPPER ASSY	
13-2-1	105130001	1	シメネジ3.57	SCREW, SM3.57	
13-3	S09679001	1	<1/4M用> ラツパー1/4Mクミ	<FOR "1/4M"> LAPPER ASSY, 1/4" M	

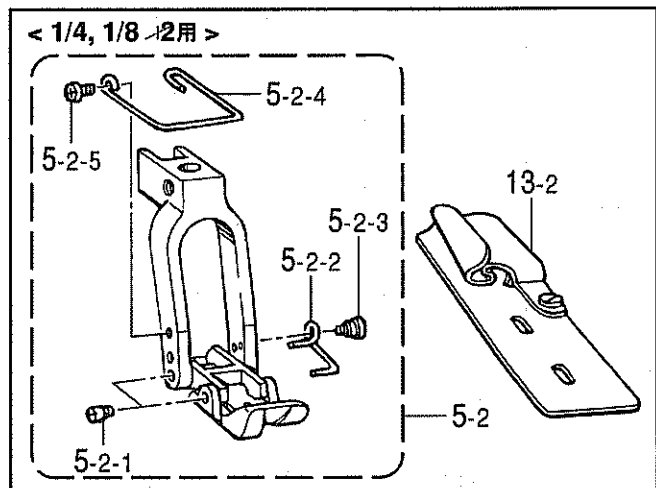
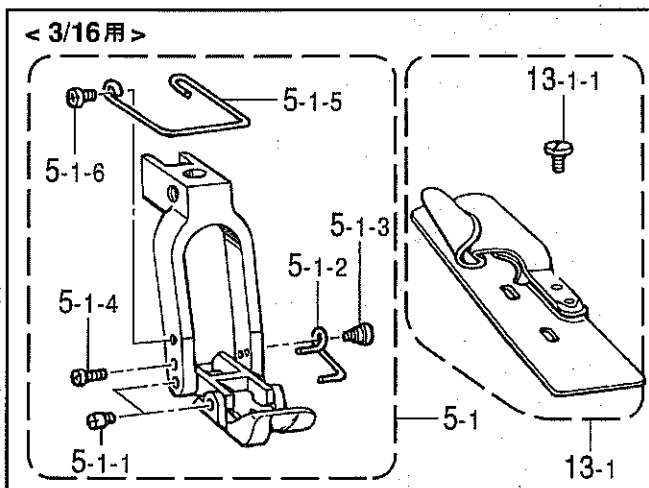
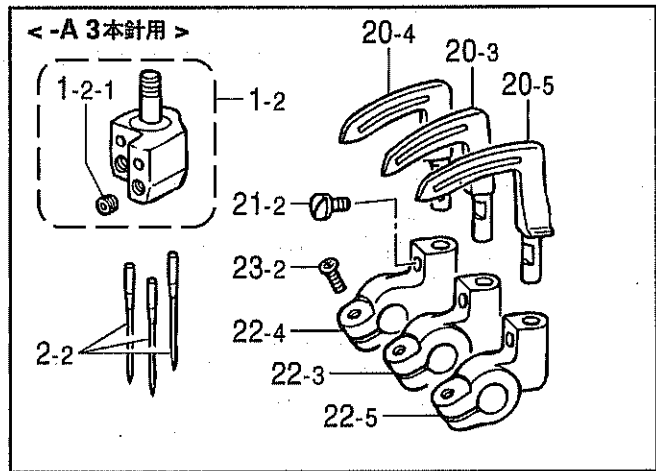
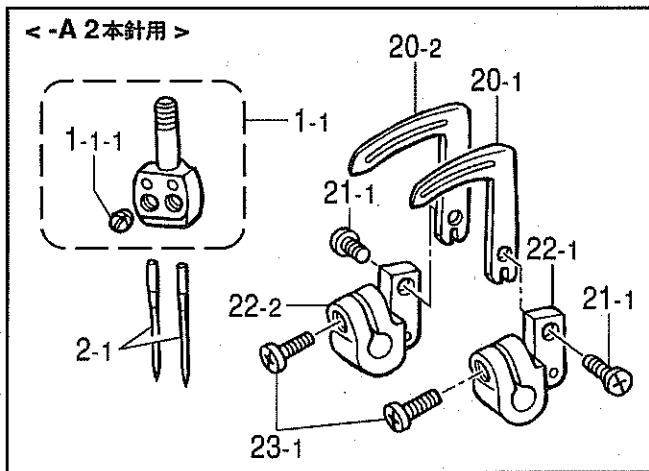
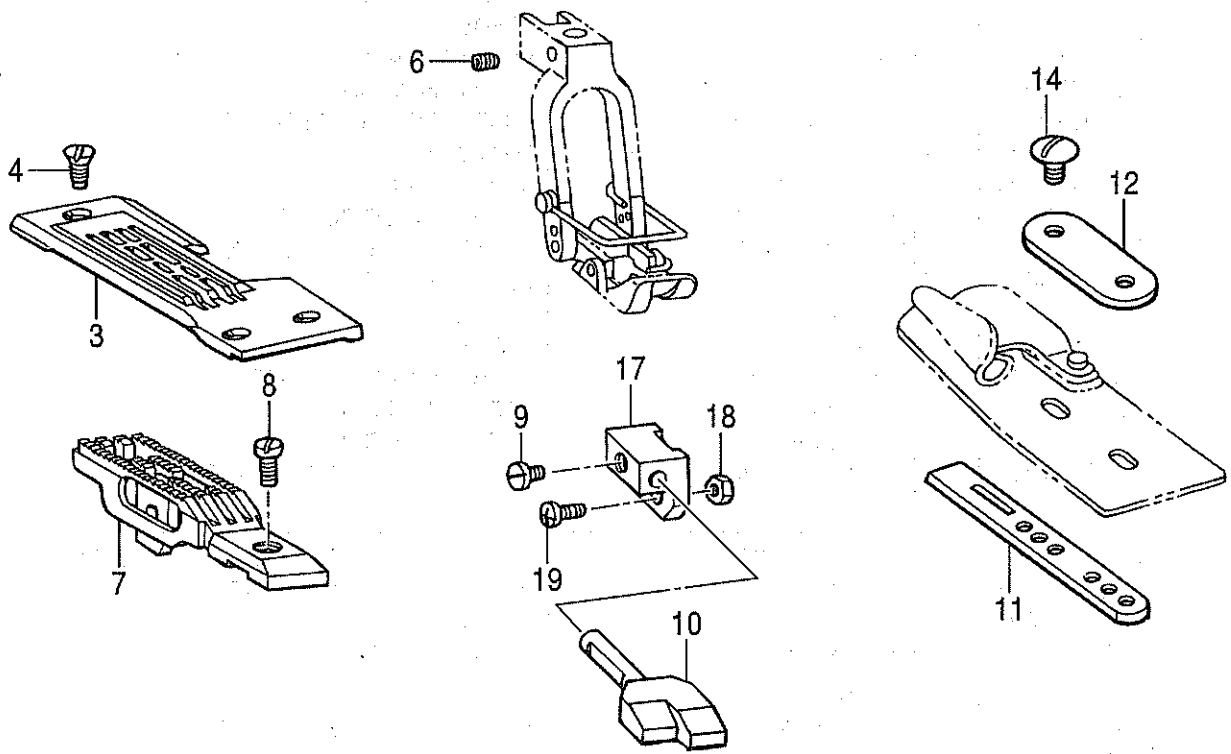

G2. ゲージ関係 (9270-A) / Gauge parts (9270-A)

REF.NO.	CODE	Q'TY	ヒンメイ	NAME OF PARTS	RM
3	※	1	ハリイタ	NEDDLE PLATE	
4	100032004	3	サラネジ4.37	SCREW, FLAT SM4.37	
6	014760622	1	アナトメネジ5.95	SET SCREW, SOCKET SM5.95	
7	※	1	オクリバ	FEED DOG	
8	105173004	1	シメネジ4.76	SCREW, SM4.76	
9	111443003	1	マルヒラトメネジ3.57	SET SCREW, SM3.57	
10	※	1	ハリウケ	NEEDLE GUARD	
11	S40399001	1	ラツパーアンナイイタ	LAPPER GUIDE PLATE	
12	105129001	1	アンナイイタザガネ	LAPPER GUIDE PLATE WASHER	
14	105130001	2	シメネジ3.57	SCREW, SM3.57	
17	148876001	1	ハリウケトリツケダイ	NEEDLE GUARD BRACKET	
18	021670102	1	ナツト1シユ3.57	NUT, 1 SM3.57	
19	062671012	1	ナベコ357-40X10	SCREW, PAN SM3.57-40X10	

1-1	※	1	ハリダキネジツキ	<FOR -A, TWIN NEEDLE> NEEDLE CALMP ASSY W/S	
1-1-1	103408002	2	トメネジ4.37	SET SCREW, SM4.37	
2-1	※	2	ミシンハリTVX64NY	NEEDLE, TVX64NY	
20-1	※	1	ルーパス	LOPPER, S	
20-2	※	1	ルーパL	LOPPER, L	
21-1	062680612	2	ナベコ4.37-40X6	SCREW, PAN SM4.37-40X6	
22-1	S06315001	1	ルーパホルダS	LOOPER HOLDER, S	
22-2	S06314001	1	ルーパホルダL	LOOPER HOLDER, L	
23-1	062681012	2	ナベコ437-40X10	SCREW, PAN SM4.37-40X10	
1-2	※	1	ハリダキネジツキ	<FOR -A, THREE NEEDLE> NEEDLE CLAMP ASSY W/S	
1-2-1	146427001	3	アナトメネジ3.18クボミ	SET SCREW, SOCKET (CP) SM3.18	
2-2	※	3	ミシンハリTVX64NY	NEEDLE, TVX64NY	
20-3	S40375001	1	ルーパス1/8X2-6	LOPPER, S 1/8"X2-6	
20-4	S40376001	1	ルーパM-6	LOPPER, M-6	
20-5	S40377001	1	ルーパL1/8X2-6	LOPPER, L 1/8"X2-6	
21-2	111443003	3	マルヒラトメネジ3.57	SET SCREW, SM3.57	
22-3	S40378051	1	ルーパホルダS	LOPPER HOLDER, S	
22-4	S40379051	1	ルーパホルダM	LOPPER HOLDER, M	
22-5	S40380051	1	ルーパホルダL	LOPPER HOLDER, L	
23-2	062671012	3	ナベコ357-40X10	SCREW, PAN SM3.57-40X10	

5-1	S06303101	1	オサエ3/16-7クミ	<FOR "3/16"> PRESSER FOOT ASSY, 3/16"-7	
5-1-1	147871001	4	オサエピン	PIN	
5-1-2	S06309001	1	オサエFバネ	SPRING	
5-1-3	147932001	1	ダンネジ2.38	SHOULDER SCREW, SM2.38	
5-1-4	062630612	1	ナベコ238-56X6	SCREW, PAN SM2.38-56X6	
5-1-5	S09180101	1	フィンガーガード	FINGER GUARD	
5-1-6	060660512	1	バインド318-40X5	SCREW, BIND SM3.18-40X5	
13-1	101494001	1	ラツパー3/16Mクミ	LAPPER ASSY, 3/16" M	
13-1-1	105130001	1	シメネジ3.57	SCREW, SM3.57	
5-2	※	1	オサエクミ	<FOR "1/4, 1/8X2"> PRESSER FOOT ASSY	
5-2-1	147871001	4	オサエピン	PIN	
5-2-2	S06309001	1	オサエFバネ	SPRING	
5-2-3	147932001	1	ダンネジ2.38	SHOULDER SCREW, SM2.38	
5-2-4	S09180101	1	フィンガーガード	FINGER GUARD	
5-2-5	060660512	1	バインド318-40X5	SCREW, BIND SM3.18-40X5	
13-2	S09679001	1	ラツパー1/4Mクミ	LAPPER ASSY, 1/4" M	

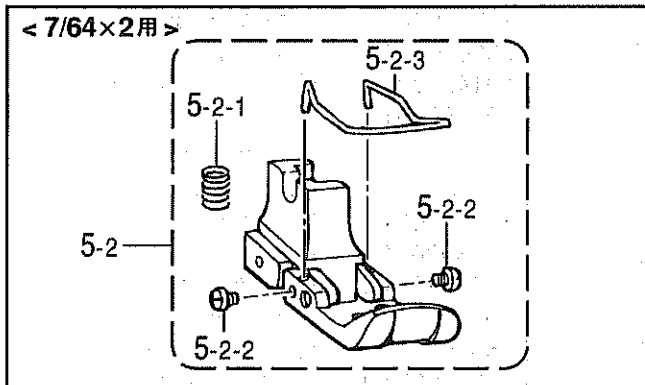
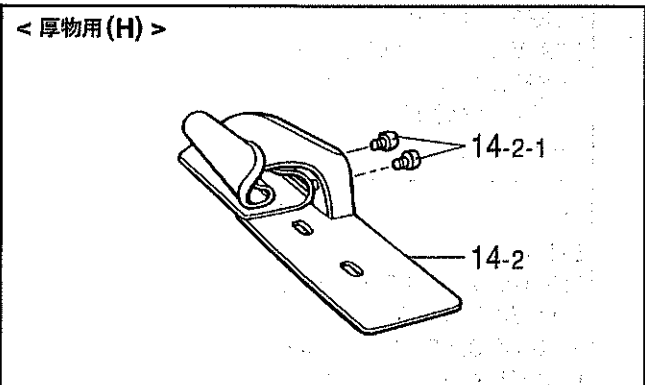
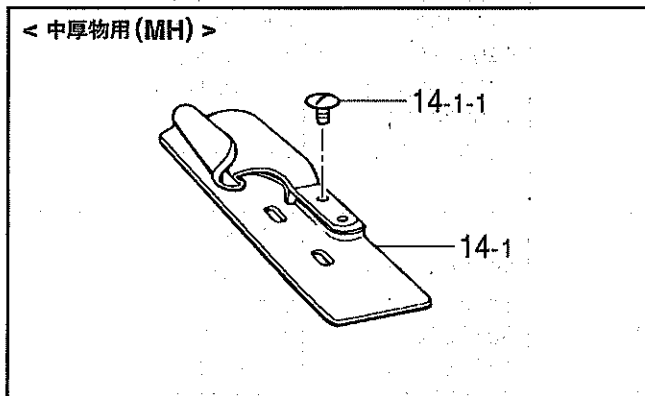
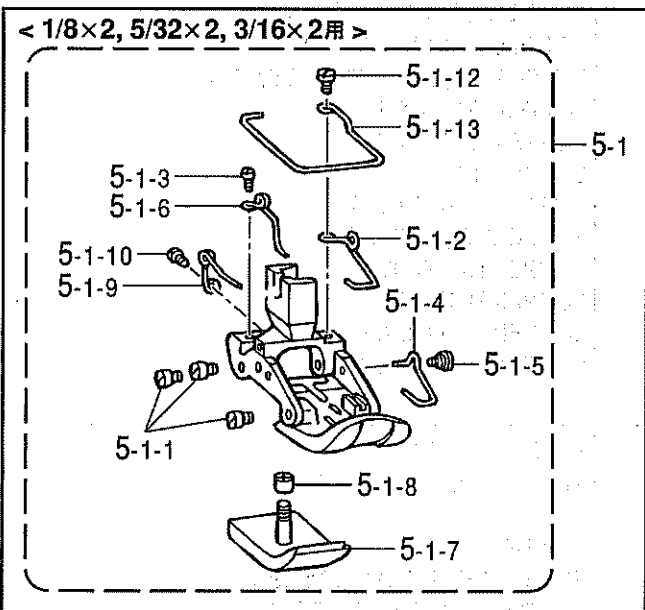
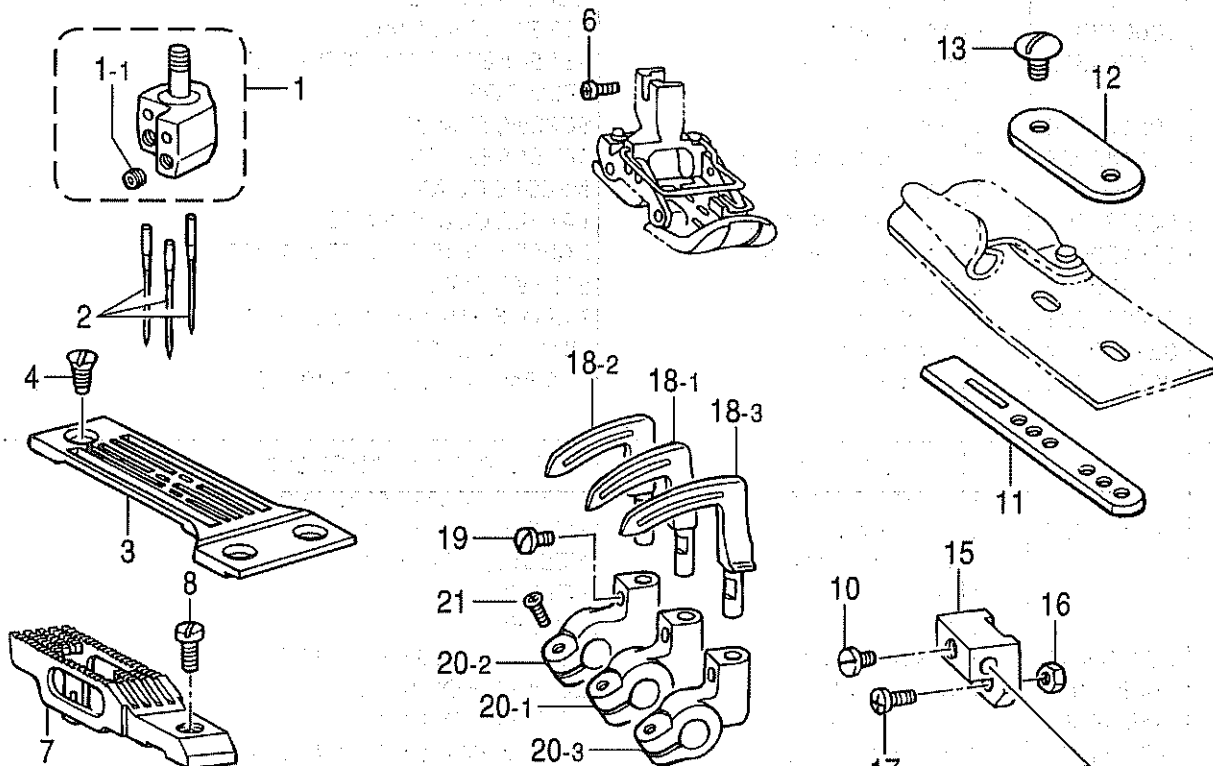

G3. ゲージ関係 (9280-5 3本針) / Gauge parts (9280-5 Three needle)

REF.NO.	CODE	Q'TY	ヒンメイ	NAME OF PARTS	RM
1	※	1	ハリダキクミ	NEEDLE CLAMP ASSY	
1-1	146427001	3	アナトメネジ3.18クボミ	SET SCREW, SOCKET (CP) SM3.18	
2	S43401021	3	ミシンハリTVX5	NEEDLE, TVX5 (#21)	
3	※	1	ハリイタ	NEEDLE PLATE	
4	100032004	3	サラネジ4.37	SCREW, FLAT SM4.37	
6	060670812	1	バインド357-40X8	SCREW, BIND SM3.57-40X8	
7	※	1	オクリバ	FEED DOG	
8	105173004	1	シメネジ4.76	SCREW, SM4.76	
9	148875001	1	ハリウケ-6	NEEDLE GUARD, -6	
10	111443003	1	マルヒラトメネジ3.57	SET SCREW, SM3.57	
11	S40399001	1	ラツパーアンナイイタ	LAPPER GUIDE PLATE	
12	105129001	1	アンナイイタザガネ	LAPPER GUIDE PLATE WASHER	
13	105130001	2	シメネジ3.57	SCREW, SM3.57	
15	148876001	1	ハリウケトリツケダイ	NEEDLE GUARD BRACKET	
16	021670102	1	ナツト1シユ3.57	NUT, 1 SM3.57	
17	062671012	1	ナベコ357-40X10	SCREW, PAN SM3.57-40X10	
18-1	※	1	ルーパス	LOPPER, S	
18-2	※	1	ルーバM	LOPPER, M	
18-3	※	1	ルーバL	LOPPER, L	
19	111443003	3	マルヒラトメネジ3.57	SET SCREW, SM3.57	
20-1	S40378051	1	ルーバホルダS	LOPPER HOLDER, S	
20-2	S40379051	1	ルーバホルダM	LOPPER HOLDER, M	
20-3	S40380051	1	ルーバホルダL	LOPPER HOLDER, L	
21	062671012	3	ナベコ357-40X10	SCREW, PAN SM3.57-40X10	
<hr/>					
5-1	※	1	<1/8X2, 5/32X2, 3/16X2用> オサエクミ	<FOR "1/8X2, 5/32X2, 3/16X2"> PRESSER FOOT ASSY	
5-1-1	147871001	6	オサエピン	PIN	
5-1-2	147872001	1	オサエMバネ	SPRING	
5-1-3	S01295001	1	シメネジ2.38X3.5	SCREW, SM2.38X3.5	
5-1-4	147890001	1	オサエFバネ	SPRING	
5-1-5	147932001	1	ダンネジ2.38	SHOULDER SCREW, SM2.38	
5-1-6	147875001	1	オサエBLバネ	SPRING	
5-1-8	147877001	1	ツマミナツト3.18	NUT, SM3.18	
5-1-9	147878001	1	オサエBSバネ	SPRING	
5-1-10	062660512	1	ナベコネジ318-40X5	SCREW, PAN SM3.18-40X5	
5-1-12	111105002	1	シメネジ2.38	SCREW, SM2.38	
5-1-13	151572101	1	フィンガーガード	FINGER GUARD	
5-1-7	S40804001	1	<5/32X2, 3/16X2用> オサエBS5/16	<FOR "5/32X2, 3/16X2"> PRESSER FOOT, BS 5/16"	
5-1-7	147876001	1	<1/8X2用> オサエBS	<FOR "1/8X2"> PRESSER FOOT, BS	
5-2	S40788001	1	<7/64X2用> オサエ7/64X2クミ	<FOR "7/64X2"> PRESSER FOOT ASSY, 7/64" X2	
5-2-1	S09397001	1	オサエオシバネ	SPRING	
5-2-2	153787001	2	シメネジ2.38	SCREW, SM2.38	
5-2-3	151571001	1	フィンガーガード	FINGER GUARD	
<hr/>					
14-1	※	1	<中厚物用 (MH)> ラツパーMHクミ	<FOR MEDIUM MATERIALS "MH"> LAPPER ASSY, MH	
14-1-1	105130001	1	シメネジ3.57	SCREW, SM3.57	
14-2	※	1	<厚物用 (H)> ラツパーHクミ	<FOR THICK MATERIALS "H"> LAPPER ASSY, H	
14-2-1	122771001	2	シメネジ2.38	SCREW, SM2.38	

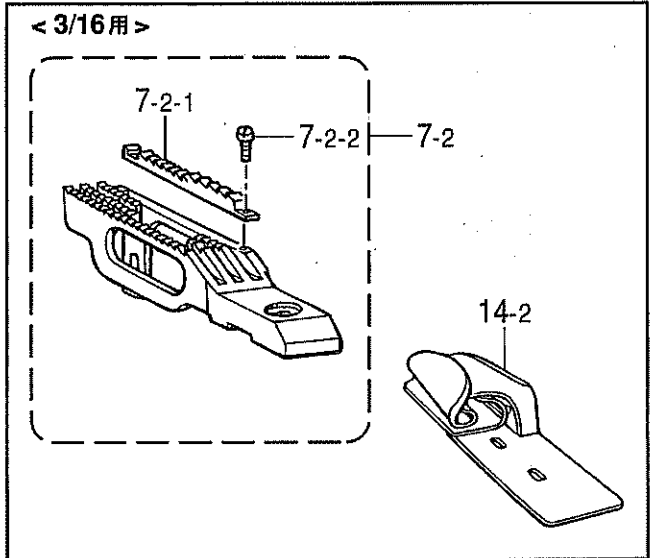
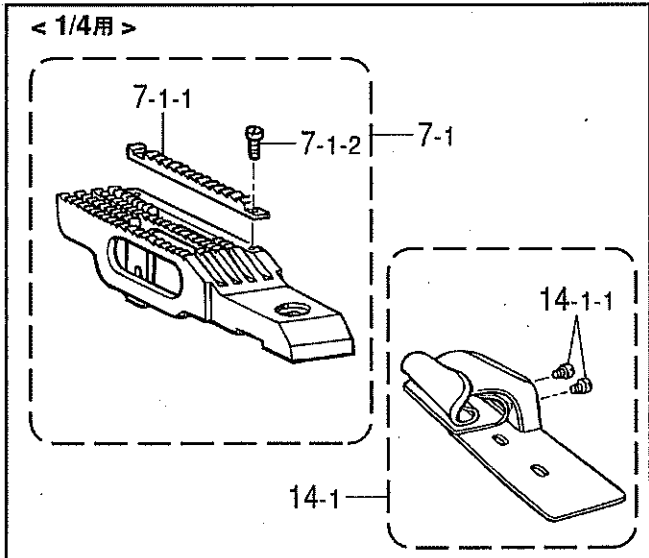
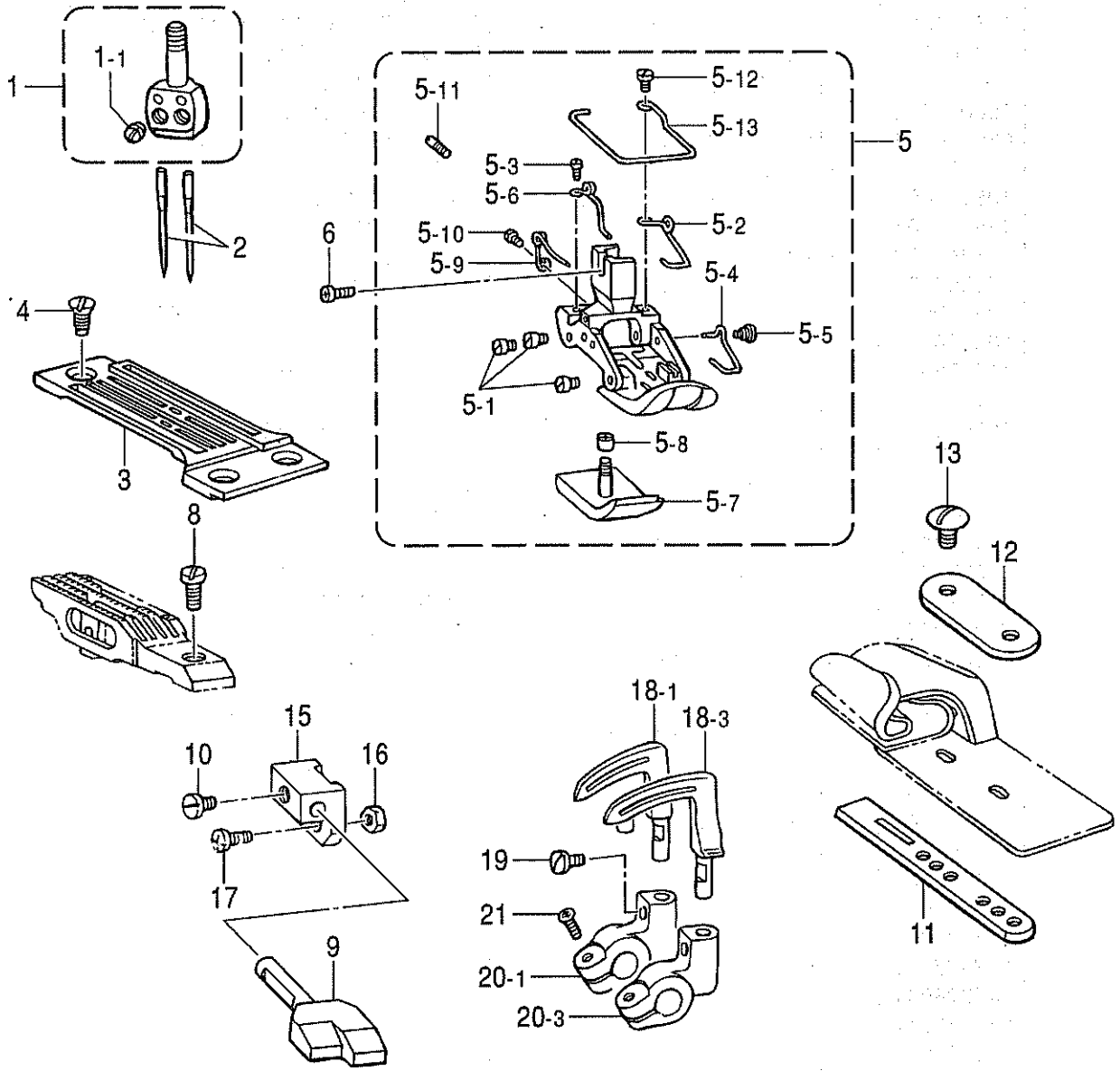

G4 . ゲージ関係 (9280-5, -7 2本針) / Gauge parts (9280-5, -7 Twin needle)

REF.NO.	CODE	Q'TY	ヒンメイ	NAME OF PARTS	RM
1	※	1	ハリダキネジツキ	NEEDLE CLAMP ASSY W/S	
1-1	103408002	2	トメネジ4.37	SET SCREW, SM4.37	
2	※	3	ミシンハリTVX5	NEEDLE, TVX5	
3	※	1	ハリイタ	NEEDLE PLATE	
4	100032004	3	サラネジ4.37	SCREW, FLAT SM4.37	
5	※	1	オサエクミ	PRESSER FOOT ASSY	
5-1	147871001	6	オサエピン	PIN	
5-2	147872001	1	オサエMバネ	SPRING	
5-3	S01295001	1	シメネジ2.38X3.5	SCREW, SM2.38X3.5	
5-4	147890001	1	オサエFバネ	SPRING	
5-5	147932001	1	ダンネジ2.38	SHOULDER SCREW, SM2.38	
5-6	147875001	1	オサエBLバネ	SPRING	
5-8	147877001	1	ツaminaツト3.18	NUT, SM3.18	
5-9	147878001	1	オサエBSバネ	SPRING	
5-10	062660512	1	ナベコネジ318-40X5	SCREW, PAN SM3.18-40X5	
5-11	147879001	1	トメネジ3.18	SET SCREW, SM3.18	
5-12	111105002	1	シメネジ2.38	SCREW, SM2.38	
5-13	151572101	1	フィンガーガード	FINGER GUARD	
6	060670812	1	バインド357-40X8	SCREW, BIND SM3.57-40X8	
8	105173004	1	シメネジ4.76	SCREW, SM4.76	
9	148973001	1	ハリウケー5	NEEDLE GUARD, -5	
10	111443003	1	マルヒラトメネジ3.57	SET SCREW, SM3.57	
11	S40399001	1	ラツパーアンナイイタ	LAPPER GUIDE PLATE	
12	105129001	1	アンナイイタザガネ	LAPPER GUIDE PLATE WASHER	
13	105130001	2	シメネジ3.57	SCREW, SM3.57	
15	148876001	1	ハリウケトリツケダイ	NEEDLE GUARD BRACKET	
16	021670102	1	ナツト1シユ3.57	NUT, 1 SM3.57	
17	062671012	1	ナベコ357-40X10	SCREW, PAN SM3.57-40X10	
18-1	S40375001	1	ルーバS1/8X2-6	LOPPER, S 1/8"X2-6	
18-3	S40377001	1	ルーバL1/8X2-6	LOPPER, L 1/8"X2-6	
19	111443003	3	マルヒラトメネジ3.57	SET SCREW, SM3.57	
20-1	S40378051	1	ルーバホルダS	LOPPER HOLDER, S	
20-3	S40380051	1	ルーバホルダL	LOPPER HOLDER, L	
21	062671012	2	ナベコ357-40X10	SCREW, PAN SM3.57-40X10	
<hr/>					
5-7	147876001	1	オサエBS	PRESSER FOOT, BS	
7-1	148971001	1	オクリバ1/4クミ	FEED DOG ASSY, 1/4"	
7-1-1	147307001	1	トリツケバ	SUB FEED DOG	
7-1-2	147880001	2	シメネジ1.98	SCREW, SM1.98	
14-1	147302001	1	ラツパー1/4XHクミ	LAPPER ASSY, 1/4" XH	
14-1-1	122771001	2	シメネジ2.38	SCREW, SM2.38	
<1/4用>				<FOR"1/4">	
5-7	159587001	1	オサエBS3/18	PRESSER FOOT, BS 3/18"	
7-2	159588001	1	オクリバ3/16クミ	FEED DOG ASSY, 3/16"	
7-2-1	159590001	1	トリツケバ	SUB FEED DOG	
7-2-2	147880001	2	シメネジ1.98	SCREW, SM1.98	
14-2	159609001	1	ラツパー3/16Hクミ	LAPPER ASSY, 3/16" H	
<3/16用>				<FOR"3/16">	

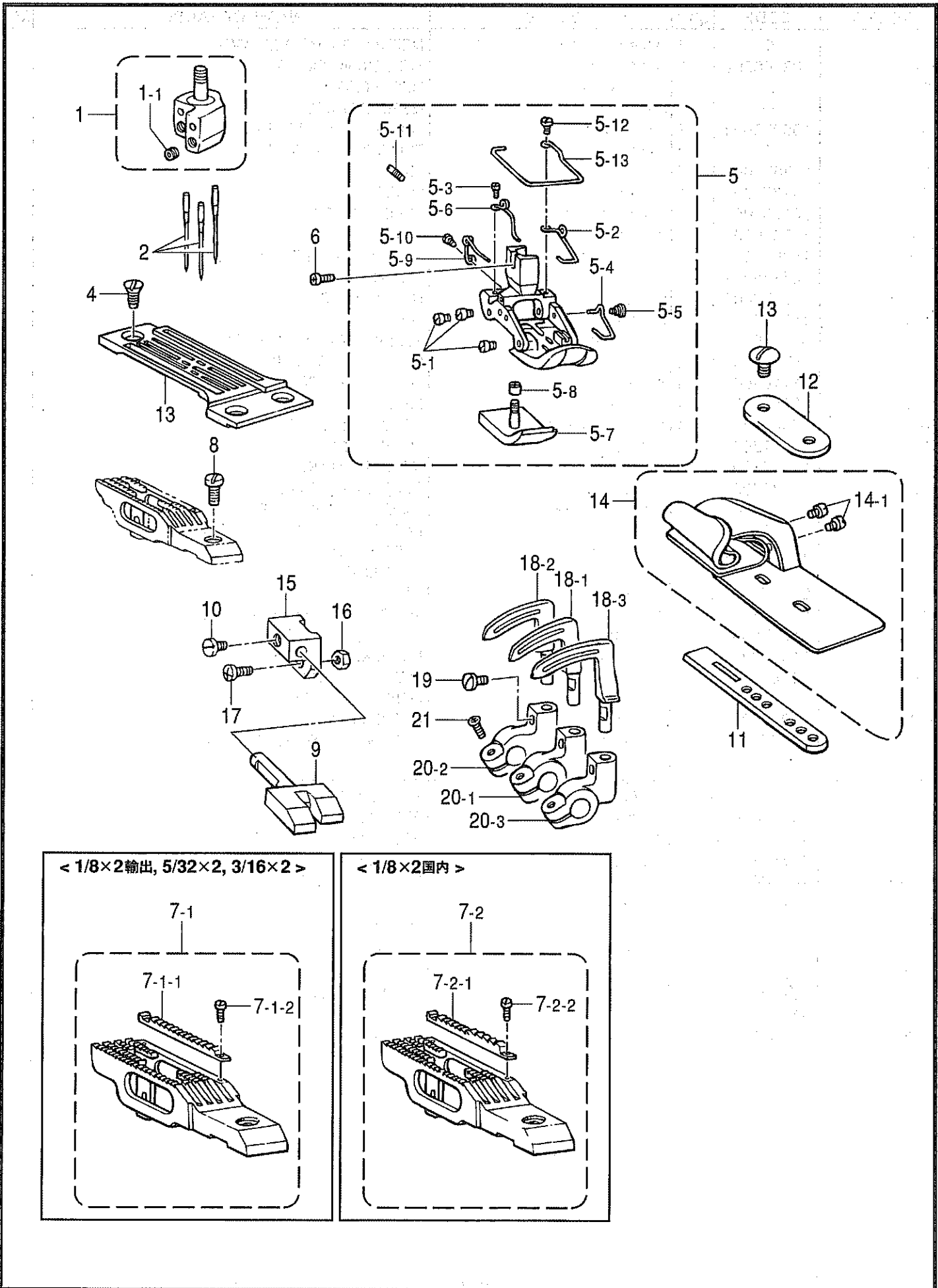

G5 . ゲージ関係 (9280-7 3本針) / Gauge parts (9280-7 Three needle)

REF.NO.	CODE	Q'TY	ヒンメイ	NAME OF PARTS	RM
1	※	1	ハリダキクミ	NEEDLE CLAMP ASSY	
1-1	146427001	3	アナトメネジ3.18クボミ	SET SCREW, SOCKET (CP) SM3.18	
2	111128022	3	ミシンハリTVX5	NEEDLE, TVX5 (#22)	
3	※	1	ハリイタ	NEEDLE PLATE	
4	100032004	3	サラネジ4.37	SCREW, FLAT SM4.37	
5	※	1	オサエクミ	PRESSER FOOT ASSY	
5-1	147871001	6	オサエピン	PIN	
5-2	147872001	1	オサエMバネ	SPRING	
5-3	S01295001	1	シメネジ2.38X3.5	SCREW, SM2.38X3.5	
5-4	147890001	1	オサエFバネ	SPRING	
5-5	147932001	1	ダンネジ2.38	SHOULDER SCREW, SM2.38	
5-6	147875001	1	オサエBLバネ	SPRING	
5-7	147876001	1	オサエBS	PRESSER FOOT, BS	
5-8	147877001	1	ツマミナツト3.18	NUT, SM3.18	
5-9	147878001	1	オサエBSバネ	SPRING	
5-10	062660512	1	ナベコネジ318-40X5	SCREW, PAN SM3.18-40X5	
5-11	147879001	1	トメネジ3.18	SET SCREW, SM3.18	
5-12	111105002	1	シメネジ2.38	SCREW, SM2.38	
5-13	151572101	1	フィンガーガード	FINGER GUARD	
6	060670812	1	バインド357-40X8	SCREW, BIND SM3.57-40X8	
8	105173004	1	シメネジ4.76	SCREW, SM4.76	
9	148875001	1	ハリウケ-6	NEEDLE GUARD, -6	
10	111443003	1	マルヒラトメネジ3.57	SET SCREW, SM3.57	
11	S40399001	1	ラツパーアンナイイタ	LAPPER GUIDE PLATE	
12	105129001	1	アンナイイタザガネ	LAPPER GUIDE PLATE WASHER	
13	105130001	2	シメネジ3.57	SCREW, SM3.57	
14	※	1	ラツパークミ	LAPPER ASSY	
14-1	122771001	2	シメネジ2.38	SCREW, SM2.38	
15	148876001	1	ハリウケトリツケダイ	NEEDLE GUARD BRACKET	
16	021670102	1	ナツト1シユ3.57	NUT, 1 SM3.57	
17	062671012	1	ナベコ357-40X10	SCREW, PAN SM3.57-40X10	
18-1	S40375001	1	ルーパS1/8X2-6	LOPPER, S 1/8"X2-6	
18-2	S40376001	1	ルーパM-6	LOPPER, M-6	
18-3	S40377001	1	ルーパL1/8X2-6	LOPPER, L 1/8"X2-6	
19	111443003	3	マルヒラトメネジ3.57	SET SCREW, SM3.57	
20-1	S40378051	1	ルーパホルダS	LOPPER HOLDER, S	
20-2	S40379051	1	ルーパホルダM	LOPPER HOLDER, M	
20-3	S40380051	1	ルーパホルダL	LOPPER HOLDER, L	
21	062671012	3	ナベコ357-40X10	SCREW, PAN SM3.57-40X10	
<hr/>					
7-1	※	1	<1/8X2輸出用, 5/32X2,3/16X2用>	<FOR EXPORT "1/5X2" & 5/32X2,3/16X2>	
7-1-1	147307001	1	オクリバクミ	FEED DOG ASSY	
7-1-2	147880001	1	トリツケバ	SUB FEED DOG	
		2	シメネジ1.98	SCREW, SM1.98	
7-2	S18084101	1	<1/8X2国内用>	<FOR JAPAN ONLY>	
7-2-1	S01637001	1	オクリバ1/8X2クミD1	-----	
7-2-2	147880001	1	トリツケバ	-----	
		2	シメネジ1.98	-----	

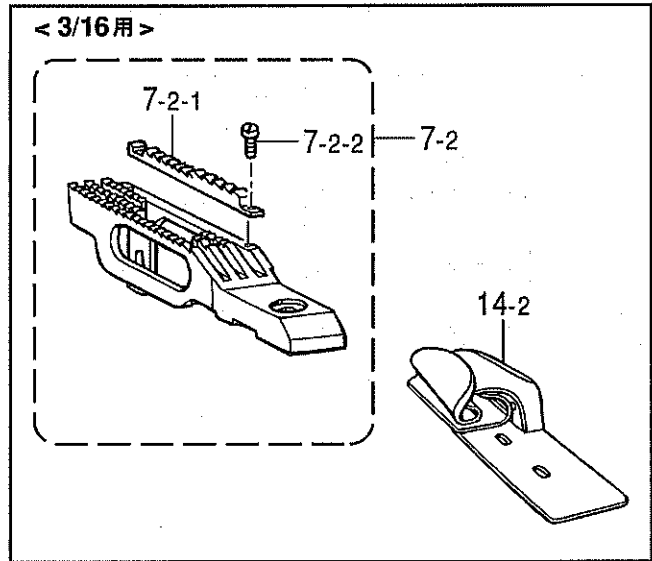
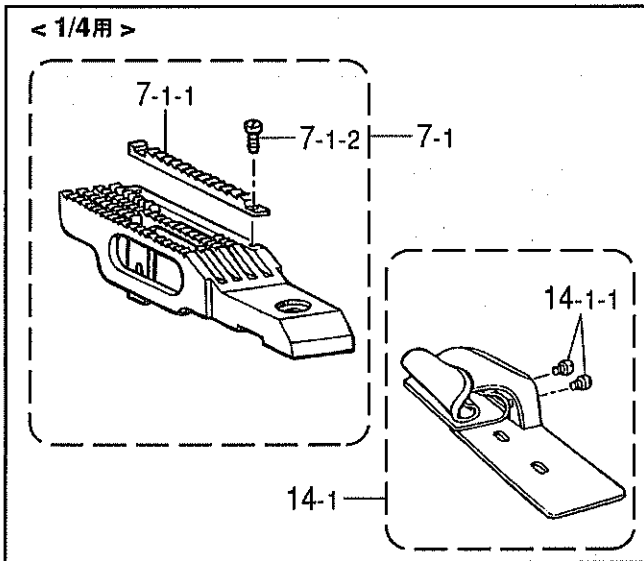
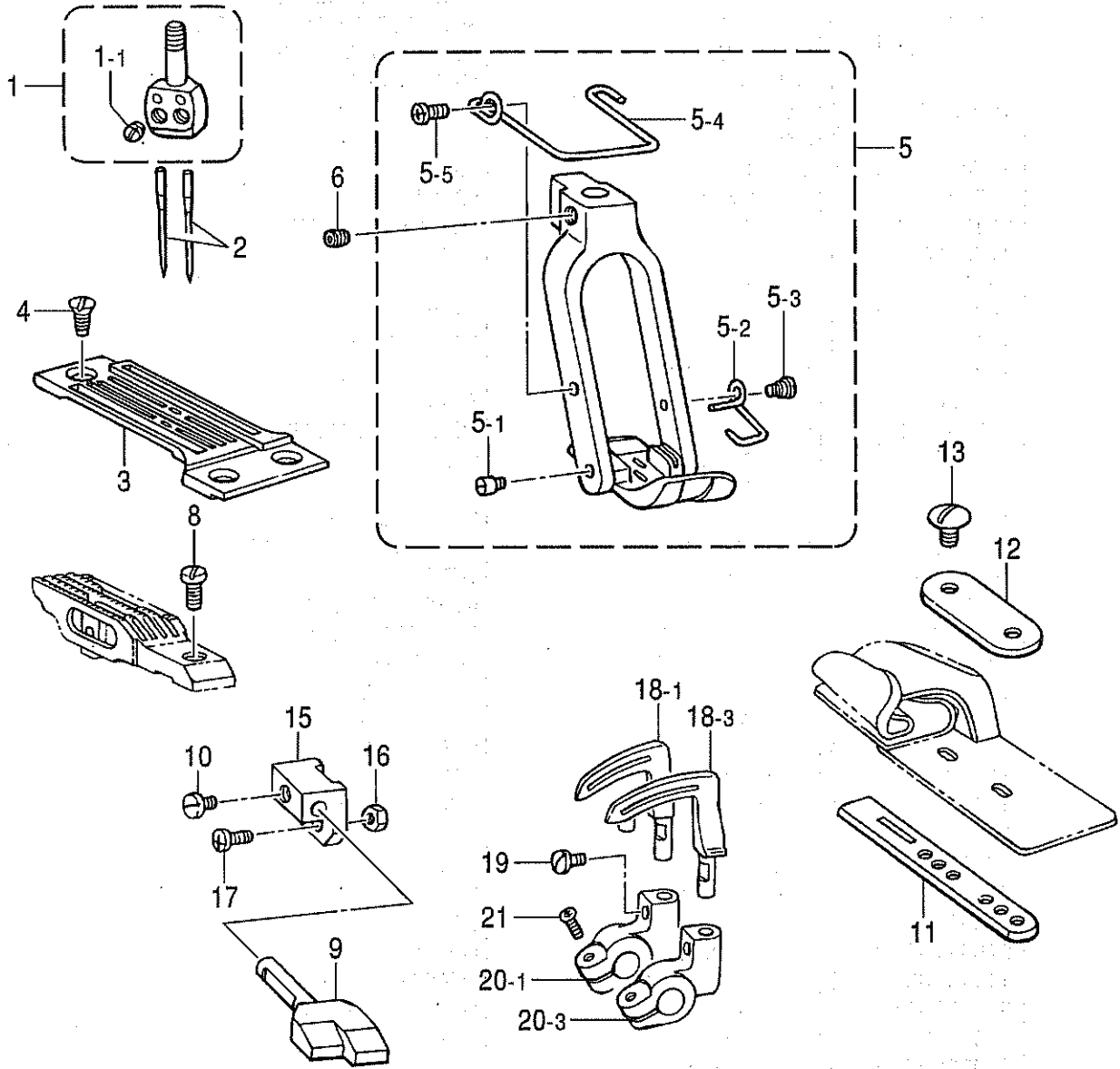

G6. ゲージ関係 (9280-C, -D 2本針) / Gauge parts (9280-C, D Twin needle)

REF.NO.	CODE	Q'TY	ヒンメイ	NAME OF PARTS	RM
1	※	1	ハリダキネジツキ	NEEDLE CLAMP ASSY W/S	
1-1	103408002	2	トメネジ4.37	SET SCREW, SM4.37	
2	※	2	ミシンハリTVX5	NEEDLE, TVX5	
3	※	1	ハリイタ	NEEDLE PLATE	
4	100032004	3	サラネジ4.37	SCREW, FLAT SM4.37	
5	※	1	オサエクミ	PRESSER FOOT ASSY	
5-1	150670001	2	オサエピン	PIN	
5-2	150671001	1	オサエFバネ	SPRING	
5-3	147932001	1	ダンネジ2.38	SHOULDER SCREW, SM2.38	
5-4	156211101	1	フィンガーガード	FINGER GUARD	
5-5	060660512	1	バインド318-40X5	SCREW, BIND SM3.18-40X5	
6	014760622	1	アナトメネジ5.95	SET SCREW, SOCKET SM5.95	
8	105173004	1	シメネジ4.76	SCREW, SM4.76	
9	148973001	1	ハリウケー5	NEEDLE GUARD, -5	
10	111443003	1	マルヒラトメネジ3.57	SET SCREW, SM3.57	
11	S40399001	1	ラツパーアンナイイタ	LAPPER GUIDE PLATE	
12	105129001	1	アンナイイタザガネ	LAPPER GUIDE PLATE WASHER	
13	105130001	2	シメネジ3.57	SCREW, SM3.57	
15	148876001	1	ハリウケトリツケダイ	NEEDLE GUARD BRACKET	
16	021670102	1	ナツト1シユ3.57	NUT, 1 SM3.57	
17	062671012	1	ナベコ357-40X10	SCREW, PAN SM3.57-40X10	
18-1	S40375001	1	ルーパS1/8X2-6	LOPPER, S 1/8"X2-6	
18-3	S40377001	1	ルーパL1/8X2-6	LOPPER, L 1/8"X2-6	
19	111443003	2	マルヒラトメネジ3.57	SET SCREW, SM3.57	
20-1	S40378051	1	ルーパホルダS	LOPPER HOLDER, S	
20-3	S40380051	1	ルーパホルダL	LOPPER HOLDER, L	
21	062671012	2	ナベコ357-40X10	SCREW, PAN SM3.57-40X10	

7-1	150673001	1	<1/4用> オクリバ1/4-7クミ	<FOR "1/4"> FEED DOG ASSY, 1/4"-7	
7-1-1	147307001	1	トリツケバ	SUB FEED DOG	
7-1-2	147880001	2	シメネジ1.98	SCREW, SM1.98	
14-1	147302001	1	ラツパー1/4XHクミ	LAPPER ASSY, 1/4" XH	
14-1-1	122771001	2	シメネジ2.38	SCREW, SM2.38	
7-2	159616001	1	<3/16用> オクリバ3/16-7クミ	<FOR "3/16"> FEED DOG ASSY, 3/16"-7	
7-2-1	159590001	1	トリツケバ	SUB FEED DOG	
7-2-2	147880001	2	シメネジ1.98	SCREW, SM1.98	
14-2	159609001	1	ラツパー3/16Hクミ	LAPPER ASSY, 3/16" H	

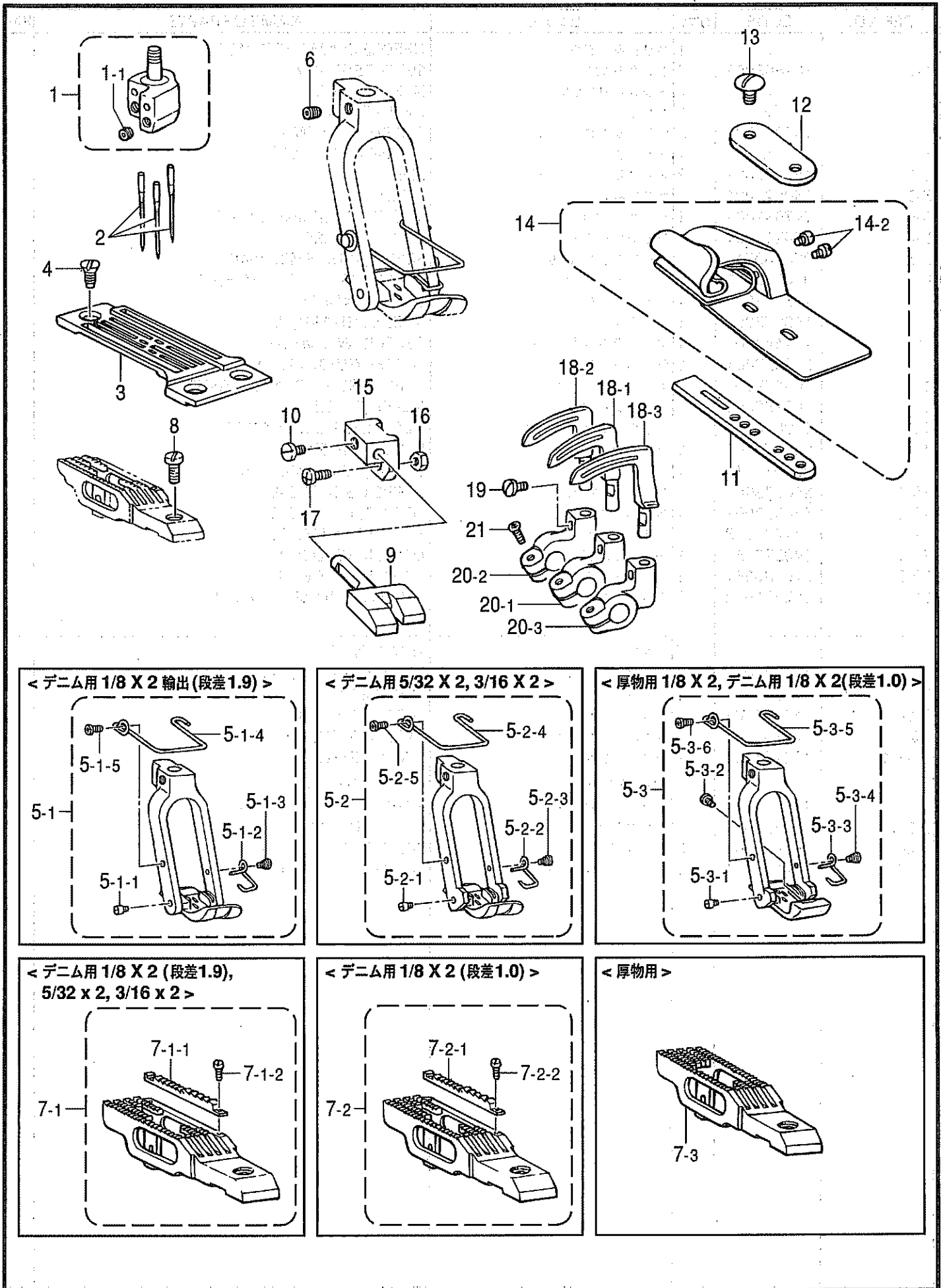

G7. ゲージ関係 (9280-C, -D 3本針) / Gauge parts (9280-C, D Three needle)

REF.NO.	CODE	Q'TY	ヒンメイ	NAME OF PARTS	RM
1	※	1	ハリダキクミ	NEEDLE CLAMP ASSY	
1-1	146427001	3	アナトメネジ3.18クボミ	SET SCREW, SOCKET (CP) SM3.18	
2	※	3	ミシンハリTVX5	NEEDLE, TVX5	
3	※	1	ハリイタ	NEEDLE PLATE	
4	100032004	3	サラネジ4.37	SCREW, FLAT SM4.37	
6	014760622	1	アナトメネジ5.95	SET SCREW, SOCKET SM5.95	
8	105173004	1	シメネジ4.76	SCREW, SM4.76	
9	148875001	1	ハリウケ-6	NEEDLE GUARD, -6	
10	111443003	1	マルヒラトメネジ3.57	SET SCREW, SM3.57	
11	S40399001	1	ラツパーアンナイイタ	LAPPER GUIDE PLATE	
12	105129001	1	アンナイイタザガネ	LAPPER GUIDE PLATE WASHER	
13	105130001	2	シメネジ3.57	SCREW, SM3.57	
14	※	1	ラツパークミ	LAPPER ASSY	
14-1	122771001	2	シメネジ2.38	SCREW, SM2.38	
15	148876001	1	ハリウケトリツケダイ	NEEDLE GUARD BRACKET	
16	021670102	1	ナツト1シユ3.57	NUT, 1 SM3.57	
17	062671012	1	ナベコ357-40X10	SCREW, PAN SM3.57-40X10	
18-1	※	1	ルーパS	LOPPER, S 1/8"X2-6	
18-2	※	1	ルーパM	LOPPER, M 1/8"X2-6	
18-3	※	1	ルーパL	LOPPER, L 1/8"X2-6	
19	111443003	3	マルヒラトメネジ3.57	SET SCREW, SM3.57	
20-1	S40378051	1	ルーパホルダS	LOPPER HOLDER, S	
20-2	S40379051	1	ルーパホルダM	LOPPER HOLDER, M	
20-3	S40380051	1	ルーパホルダL	LOPPER HOLDER, L	
21	062671012	3	ナベコ357-40X10	SCREW, PAN SM3.57-40X10	
<hr/>					
5-1	150672101	1	<デニム用1/8X2輸出段差1.9> オサエ1/8X2-8クミ	<For Export Denim "1/8X2"> PRESSER FOOT ASSY, 1/8"X2-8	
5-1-1	150670001	2	オサエピン	PIN	
5-1-2	150671001	1	オサエFバネ	SPRING	
5-1-3	147932001	1	ダンネジ2.38	SHOULDER SCREW, SM2.38	
5-1-4	156211101	1	フィンガーガード	FINGER GUARD	
5-1-5	060660512	1	バインド318-40X5	SCREW, BIND SM3.18-40X5	
5-2	151487101	1	<デニム用5/32X2, 3/16X2> オサエ5/32X2-8クミ	<For Denim 5/32X2, 3/16X2> PRESSER FOOT ASSY, 5/32"X2-8	
5-2-1	151481001	2	オサエピン	PIN	
5-2-2	151482001	1	オサエFバネ	SPRING	
5-2-3	147932001	1	ダンネジ2.38	SHOULDER SCREW, SM2.38	
5-2-4	156211101	1	フィンガーガード	FINGER GUARD	
5-2-5	060660512	1	バインド318-40X5	SCREW, BIND SM3.18-40X5	
5-3	※	1	<厚物用1/8x2, デニム1/8x2段差1.0> オサエ1/8X2-8クミ	<For Thick & Denim materials "1/8X2"> PRESSER FOOT ASSY, FT 1/8"X2-8	
5-3-1	150670001	2	オサエピン	PIN	
5-3-2	142747002	1	シメネジ4.76	SET SCREW, SM4.76	
5-3-3	150671001	1	オサエFバネ	SPRING	
5-3-4	147932001	1	ダンネジ2.38	SHOULDER SCREW, SM2.38	
5-3-5	156211101	1	フィンガーガード	FINGER GUARD	
5-3-6	060660512	1	バインド318-40X5	SCREW, BIND SM3.18-40X5	
<hr/>					
7-1	※	1	<デニム1/8x2段差1.9, 5/32x2, 3/16x2> オクリバクミ	<For Denim "1/8X2, 5/32X2 & 3/16X2"> FEED DOG ASSY, 1/4"-7	
7-1-1	147307001	1	トリツケバ	SUB FEED DOG	
7-1-2	147880001	2	シメネジ1.98	SCREW, SM1.98	
7-2	S01635101	1	<デニム用1/8x2段差1.0> オクリバ1/8X2-8クミ	<For Denim "1.8X2"> FEED DOG ASSY, 1/8"X2-8	
7-2-1	S01637001	1	トリツケバ	SUB FEED DOG	
7-2-2	147880001	2	シメネジ1.98	SCREW, SM1.98	
7-3	156182101	1	<厚物用> オクリバ1/8X2-8	<FOR HEAVY MATERIALS> FEED DOG, 1/8"X2-8	

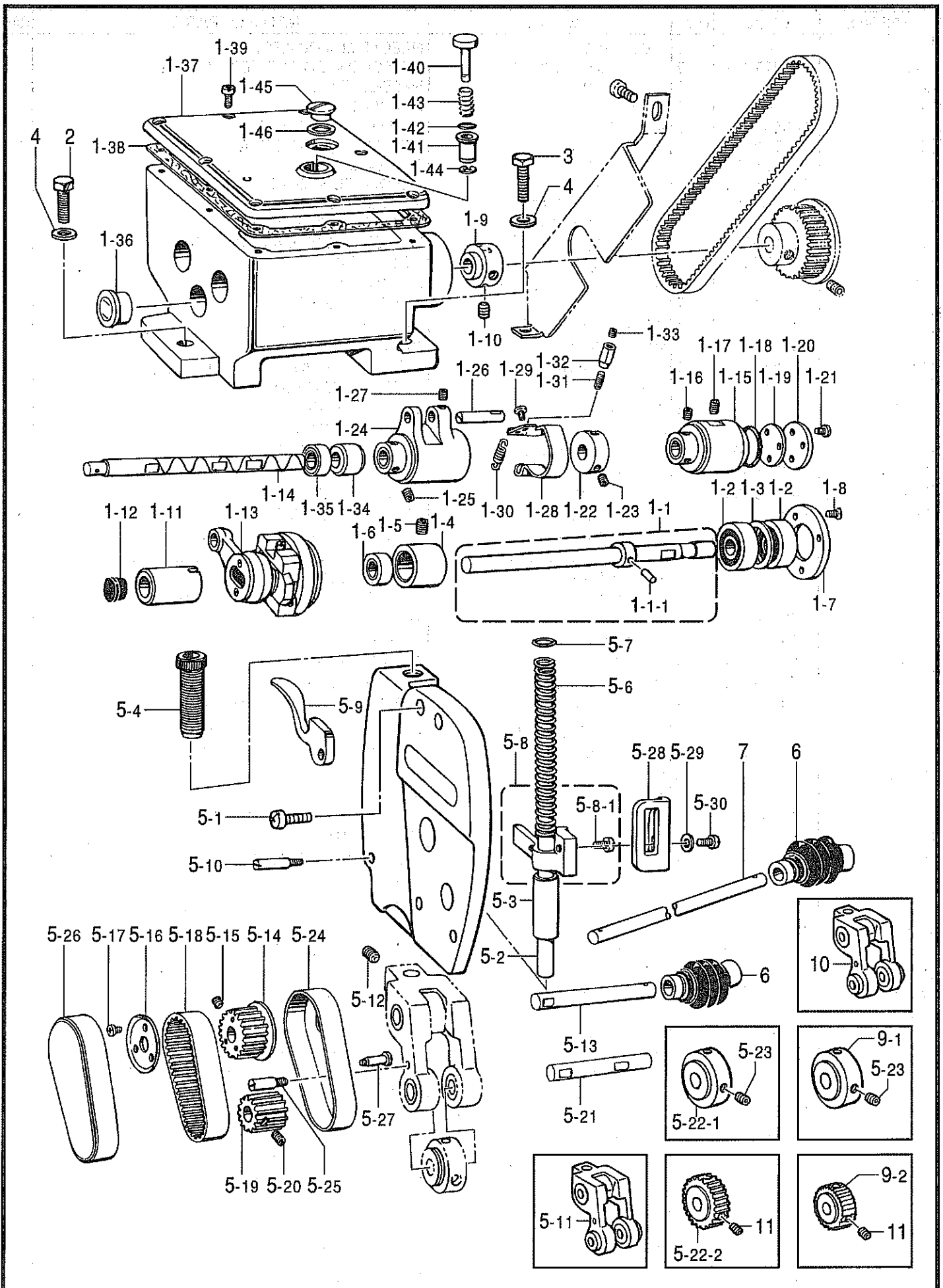

H. プーラ装置関係 (-A, -C, -D) / Puller device mechanism (-A, -C, -D)

REF.NO.	CODE	Q'TY	ヒンメイ	NAME OF PARTS	RM
1-1	150679001	1	ヘンシンリンジククミ	ECCENTRIC WHEEL SHAFT ASSY	
1-1-1	047201640	1	スプリングピンAW2	PIN, SPRING ROLL AW2	
1-2	072600040	2	タマジクウケ6000DD	BALL BEARING, 6000DD	
1-3	150682000	1	ベアリングカラー	BEARING COLLAR	
1-4	150683000	1	ベアリングブシュ	BEARING BUSH	
1-5	014760622	1	アナトメネジ5.95	SET SCREW, SOCKET SM5.95	
1-6	150684001	1	オイルシール	OIL SEAL	
1-7	S25125001	1	ベアリングフタ	BEARING COVER	
1-8	062670712	3	ナベコ357-40X7	SCREW, PAN SM3.57-40X7	
1-9	150686101	1	タイミングカラー	TIMING COLLAR	
1-10	014760622	2	アナトメネジ5.95	SET SCREW, SOCKET SM5.95	
1-11	150687000	1	ヘンシンリンジクメタル	ECCENTRIC WHEEL SHAFT BUSH	
1-12	117934009	1	ゴムセン13.5	RUBBER CAP, 13.5	
1-13	150688101	1	ヘンシンリンクミ	ECCENTRIC WHEEL ASSY	
1-14	150690101	1	オクリジク	FEED SHAFT	
1-15	S36058001	1	クラツチメタルクミ	CLUTCH BUSH ASSY	
1-16	014760622	2	アナトメネジ5.95	SET SCREW, SOCKET SM5.95	
1-17	014760622	1	アナトメネジ5.95	SET SCREW, SOCKET SM5.95	
1-18	081025570	1	OリングP25.5	O RING, P25.5	
1-19	150693000	1	パツキン	PACKING	
1-20	S25126001	1	クラツチメタルフタ	CLUTCH BUSH CAP	
1-21	062670712	3	ナベコ357-40X7	SCREW, PAN SM3.57-40X7	
1-22	150680001	1	セツトカラー	SET SCREW COLLAR	
1-23	014760622	2	アナトメネジ5.95	SET SCREW, SOCKET SM5.95	
1-24	S36061001	1	クラツチクミ	CLUTCH ASSY	
1-25	014760622	2	アナトメネジ5.95	SET SCREW, SOCKET SM5.95	
1-26	109153001	1	ピン	PIN	
1-27	014680422	1	アナトメネジ4.37クボミ	SET SCREW, SOCKET (CP) SM4.37	
1-28	150611001	1	ブレーキイタバネ	PLATE SPRING	
1-29	062680512	2	ナベコ437-40X5	SCREW, PAN SM4.37-40X5	
1-30	150612001	1	ブレーキバネ	SPRING	
1-31	150613001	1	ブレーキバネカケ	SPRING HOOK	
1-32	150614001	1	ブレーキバネカケブシュ	SPRING HOOK BUSH	
1-33	148294001	1	アナトメネジ3.57クボミ	SET SCREW, SOCKET (CP) SM3.57	
1-34	150695000	1	オクリジクメタル	FEED SHAFT BUSH	
1-35	150696001	1	オイルシール	OIL SEAL	
1-36	150697001	1	オイルボツトマド	OIL GAUGE WINDOW	
1-37	150698009	1	プーラソウチウワフタ	PULLER DEVICE TOP COVER	
1-38	150699000	1	パツキン	PACKING	
1-39	062671012	8	ナベコ357-40X10	SCREW, PAN SM3.57-40X10	
1-40	150641001	1	オクリチヨウセツボタン	FEED ADJUST BUTTON	
1-41	150700001	1	チヨウセツボタンブシュ	FEED REGURATE BUTTON BUSH	
1-42	081003670	1	OリングPW3	O RING, PW3	
1-43	150701001	1	オクリチヨウセツボタンバネ	SPRING	
1-44	048040342	1	トメワE4	RETAINING RING, E4	
1-45	105113001	1	シメネジ12.70	SCREW, SM12.70	
1-46	105215001	1	パツキン	PACKING	
2	017822212	1	ボルト7.94X22	BOLT, SM7.94X22	
3	017821813	2	ボルト7.94X18	BOLT, SM7.94X18	
4	025080132	3	ヒラザガネシヨウ8	WASHER, PLAIN S 8	
5-1	062681012	4	ナベコ437-40X10	SCREW, PAN SM4.37-40X10	
5-2	150704001	1	プーラオサエボウ	PULLER PRESSER BAR	
5-3	S41314000	1	オサエボウメタルD	PRESSER BAR BUSH, D	
5-4	100279109	1	オサエチヨウセツネジ	PRESSER ADJUST SCREW	
5-6	106794001	1	オサエバネ	SPRING	
5-7	141099001	1	オサエバネザガネ	SPRING WASHER	
5-8	183128001	1	オサエボウアンナイクミ	PRESSER BAR GUIDE ASSY	
5-8-1	062680712	1	ナベコ437-40X7	SCREW, PAN SM4.37-40X7	
5-9	112618001	1	オサエアゲ	PRESSER FOOT LIFTER	

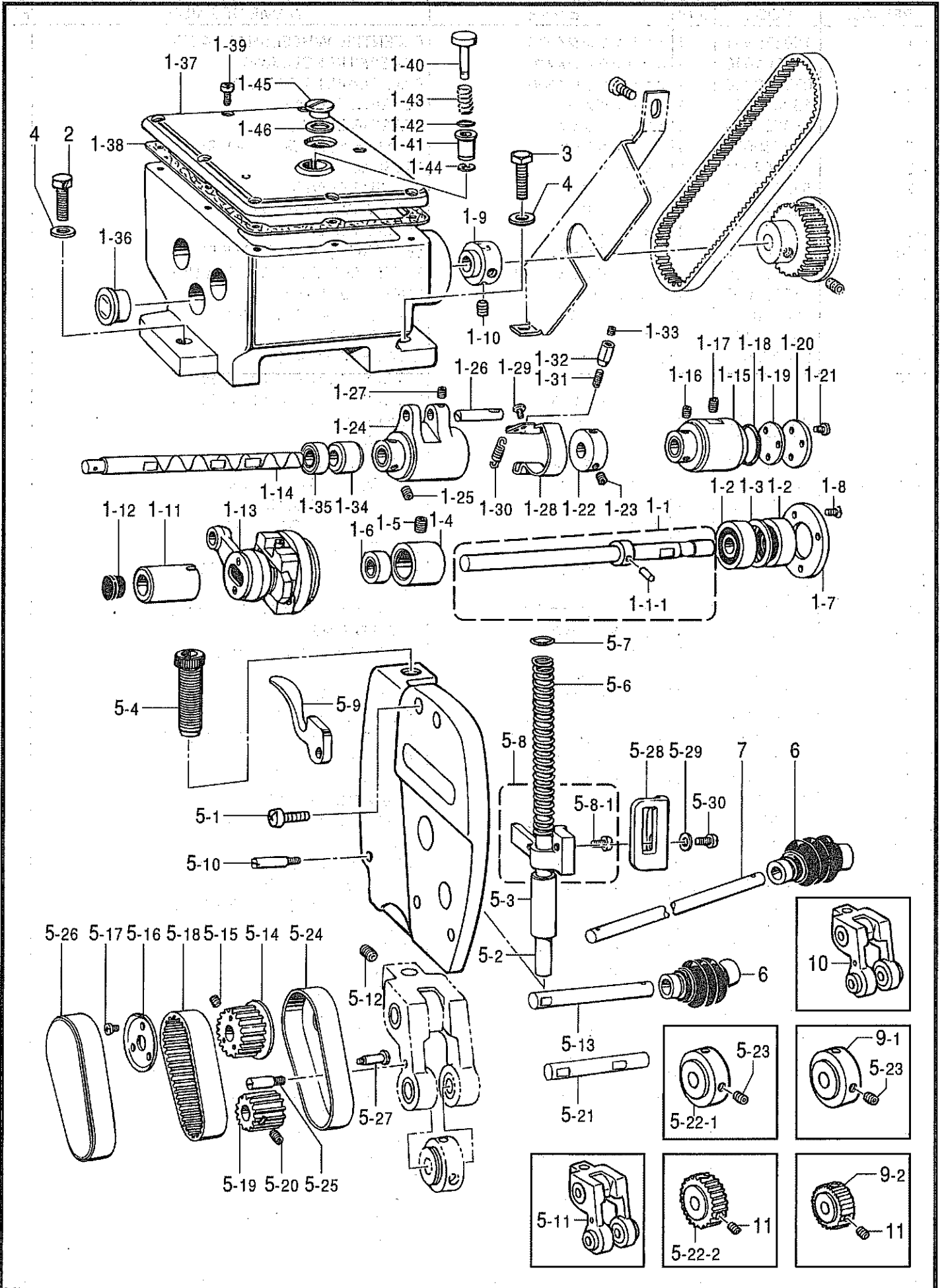

H. プーラ装置関係 (-A, -C, -D) / Puller device mechanism (-A, -C, -D)

REF.NO.	CODE	Q'TY	ヒンメイ	NAME OF PARTS	RM
5-10	150705001	1	テコササエジク	SUPPORT STUD	
5-12	014770622	1	アナトメネジ6.35クボミ	SET SCREW, SOCKET (CP) SM6.35	
5-13	150711001	1	タイミングプーリジク	TIMING PULLEY SHAFT	
5-14	150712001	1	タイミングプーリCクミ	TIMING PULLEY ASSY, C	
5-15	014680422	2	アナトメネジ4.37クボミ	SET SCREW, SOCKET (CP) SM4.37	
5-16	150715001	1	フランジB	FLANGE, B	
5-17	106568003	3	シメネジ3.57	SCREW, SM3.57	
5-18	150716001	1	プーラタイミングベルトB	PULLER TIMING BELT, B	
5-19	150717000	1	タイミングプーリD	TIMING PULLEY, D	
5-20	014680422	2	アナトメネジ4.37クボミ	SET SCREW, SOCKET (CP) SM4.37	
5-21	150718001	1	プーラジク	PULLER SHAFT	
5-24	150720001	1	カバーD	TIMING BELT COVER, D	
5-25	150721001	1	スタツド	STUD	
5-26	150722001	1	カバーU	TIMING BELT COVER, U	
5-27	150723001	1	ダンネジ3.57	SHOULDER SCREW, SM3.57	
5-28	153965001	1	プーラオサエボウアゲ	PULLER PRESSER BAR LIFTER	
5-29	025060232	1	ヒラザガネチユウ6	WASHER, PLAIN M 6	
5-30	062761012	1	ナベコ595-28X10	SCREW, PAN SM5.95-28X10	
6	150725001	2	カバーツキジザイツギテ	UNIVERSAL JOINT ASSY	
7	150726001	1	ツギテジク	UNIVERSAL JOINT SHAFT	
10	S16488001	1	<9270用> プーラササエクミ	<FOR 9270> PULLER SUPPORT ASSY	
5-11	150706001	1	<9280用> プーラササエクミ	<FOR 9280> PULLER SUPPORT ASSY	
5-22-1	506311201	1	<9270-A, 3/16"用> プーラ	<FOR 9270-A> PULLER	
5-23	014680622	2	アナトメネジ4.37クボミ	SET SCREW, SOCKET (CP) SM4.37	
5-22-2	S41315001	1	<9280-D用> プーラ	<FOR 9280-D> PULLER	
11	014760622	2	アナトメネジ5.95	SET SCREW, SOCKET SM5.95	
9-1	154344201	1	<9270-A 1/4用, 1/8X2用, 9280-C用> プーラ	<FOR 9270-A 1/4", 1/8X2 & 9280-C> PULLER	
5-23	014680422	2	アナトメネジ4.37クボミ	SET SCREW, SOCKET (CP) SM4.37	
9-2	150719001	1	<9280-D 1/8X2 国内用> プーラ	<FOR 9280-D 1/8X2 Japan> PULLER	
11	014760622	2	アナトメネジ5.95	SET SCREW, SOCKET SM5.95	

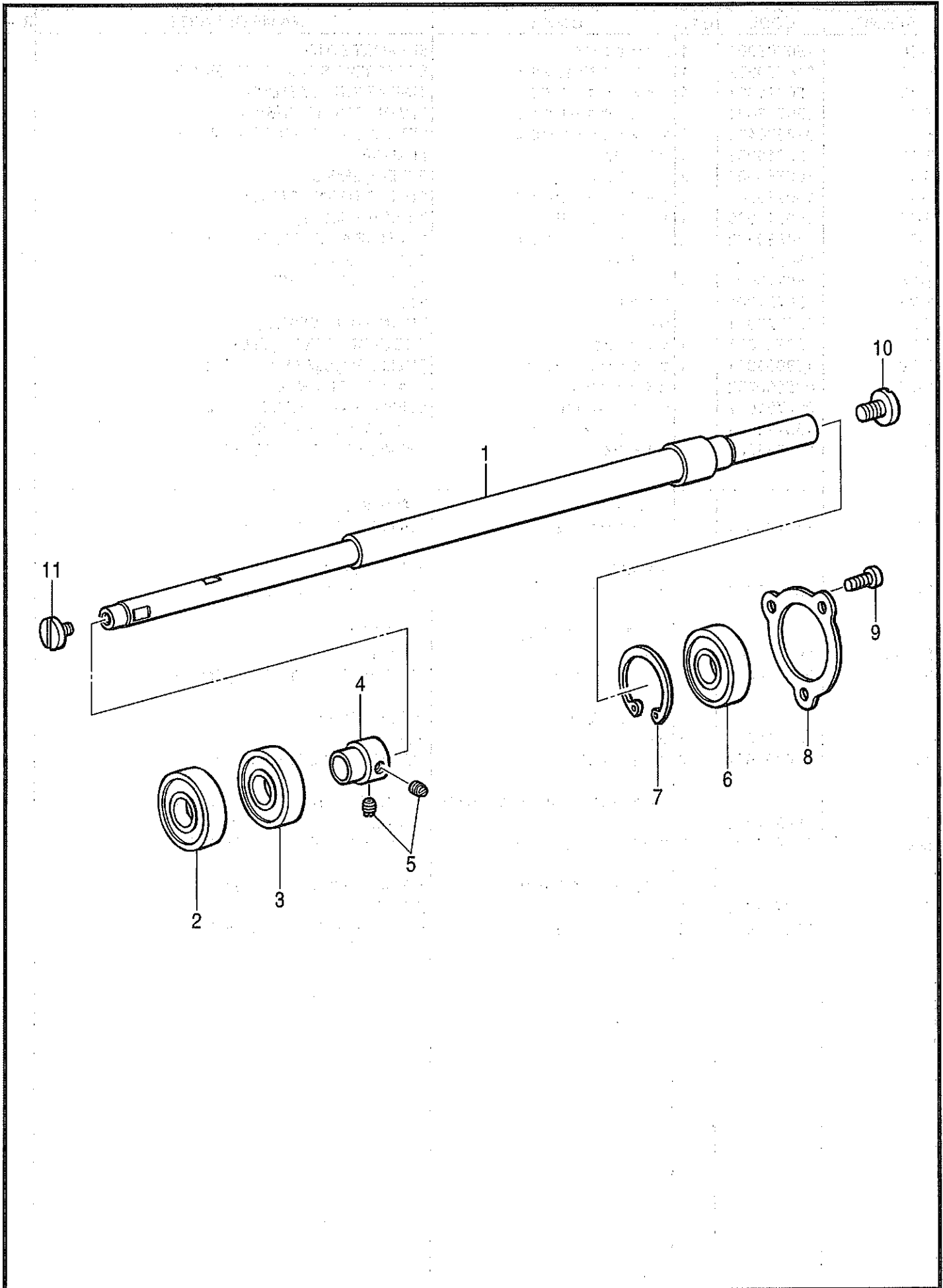

J. 下軸関係 / Lower shaft mechanism

REF.NO.	CODE	Q'TY	ヒンメイ	NAME OF PARTS	RM
1	105147101	1	シタジク	LOWER SHAFT	
2	072620070	1	タマジクウケ6200Z	BALL BEARING, 6200Z	
3	072620180	1	タマジクウケ6201ZZ	BALL BEARING, 6201ZZ	
4	105150000	1	タマジクウケブシユ	BALL BEARING BUSH	
5	102716004	2	トメネジ4.37	SET SCREW, SM4.37	
6	072630260	1	ベアリング6302VV	BALL BEARING, 6302VV	
7	048420242	1	トメワアナヨウC42	RETAINING RING, C42	
8	S40316051	1	ベアリングオサエ	BEARING PRESSER	
9	062711012	3	ナベコ476-32X10	SCREW, PAN SM4.76-32X10	
10	105155001	1	シメネジ6.35	SCREW, SM6.35	
11	105156002	1	シメネジ4.37	SCREW, SM4.37	

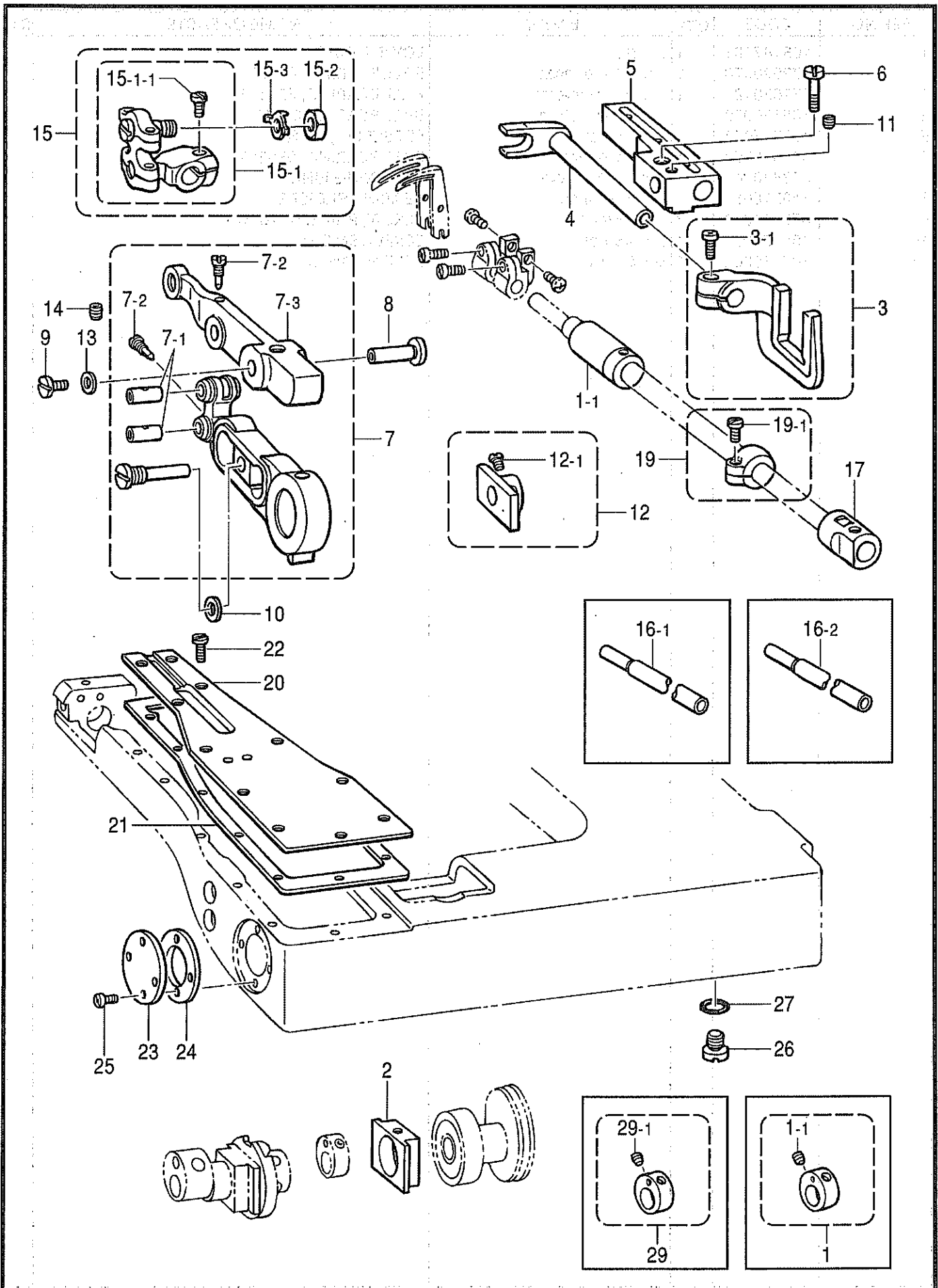

K. ルーパー関係 / Lopper mechanism

REF.NO.	CODE	Q'TY	ヒンメイ	NAME OF PARTS	RM
2	S40302000	1	ヘンシンリンスリーブ	ECCENTRIC WHEEL SLEEVE	
3	181993101	1	ゼンゴフタマタクミ	LOPPER FEEDING FORK ASSY	
3-1	105176001	1	シメネジ4.37	SCREW, SM4.37	
4	105177001	1	ゼンゴフタマタジク	LOOPER FEEDING FORK SHAFT	
5	105178100	1	ゼンゴフタマタジクウケ	LOPPER F/FORK SHAFT BRACKET	
6	105179001	1	シメネジ4.76	SCREW, SM4.76	
7	S40303001	1	ルーバレンカンクミ	LOPPER CONNECTING ROD ASSY	
7-1	105183001	2	ルーバリンクジク	LOOPER LINK SHAFT	
7-2	105184000	2	シメネジ2.38	SCREW, SM2.38	
7-3	S40792001	1	ルーバレバー	LOPPER LEVER	
8	S40793051	1	ルーバレバージュク	LOPPER LEVER SHAFT	
9	105191001	1	シメネジ4.37	SCREW, SM4.37	
10	081010870	1	OリングS10	O RING, S10	
11	100260001	1	トメネジ5.95	SET SCREW, SM5.95	
12	181987001	1	ルーバレンカンアンナイイタ	LOOPER CONNECT. ROD GUIDE ASSY	
12-1	100366001	2	マルヒラトメネジ4.37	SET SCREW, (FT) SM4.37	
13	081003670	1	OリングPW3	O RING, PW3	
14	014761030	1	アナクボミ595-28X10	SET SCREW, SOCKET (CP) SM5.95	
15	105193101	1	ルーバジクリンククミ	LOOPER SHAFT LINK ASSY SET	
15-1	183185101	1	ルーバジクリンククミ	LOOPER SHAFT LINK ASSY SET	
15-1-1	105176001	1	シメネジ4.37	SCREW, SM4.37	
15-2	100022004	1	ナツト5.95	NUT, SM5.95	
15-3	105198000	1	タマジクザガネ	WASHER	
17	105201000	1	ルーバジクメタルF	LOOPER SHAFT BUSH, F	
18	148877100	1	ルーバジクメタルB	LOOPER SHAFT BUSH, B	
19	181971001	1	ルーバジクセットカラー	LOOPER SHAFT SET COLLAR	
19-1	062680812	1	ナベコ437-40X8	SCREW, PAN SM4.37-40X8	
20	S40306001	1	マエオクリウデフタ	FRONT FEED ARM CAP	
21	S40307001	1	マエオクリウデフタパツキン	PACKING	
22	105216001	11	シメネジ3.57	SCREW, SM3.57	
23	105217059	1	タマジクウケフタ	BALL BEARING	
24	S40308001	1	タマジクウケフタパツキン	PACKING	
25	062670512	4	ナベコ357-40X5	SCREW, PAN SM3.57-40X5	
26	140518001	1	シメネジ7.94	SCREW, SM7.94	
27	081007070	1	OリングP7	O RING, P7	
16-1	105200101	1	<9270固定針受用> ルーバジク	<FOR 9270 FIX NEEDLE SUPPORT> LOPPER SHAFT	
16-2	S16490101	1	<9270移動針受用, 9280用> ルーバジク	<FOR 9270 MOVEABLE NEEDLE SUPPORT & 9280> LOOPER SHAFT	
1	181126001	1	<9280用> ヘンシンリンネジツキ	<FOR 9280> ECCENTRIC WHEEL WITH SCREW	
1-1	153675001	2	アナトメネジ4.37	SET SCREW, SOCKET SM4.37	
29	S36862001	1	<9270用> ヘンシンリンネジツキ	<FOR 9270> ECCENTRIC WHEEL WITH SCREW	
29-1	153675001	2	アナトメネジ4.37	SET SCREW, SOCKET SM4.37	

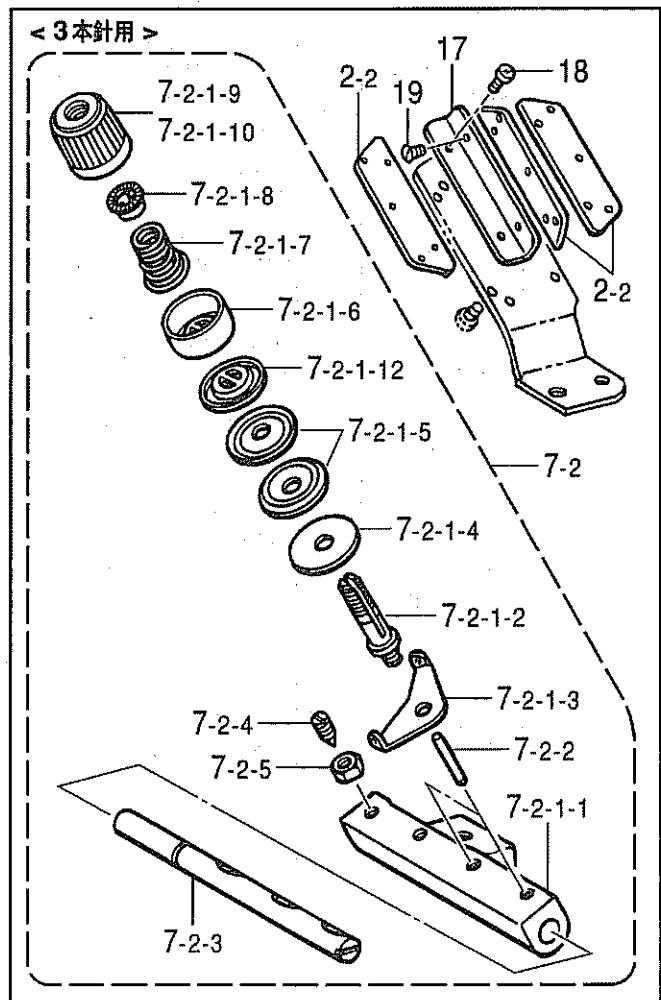
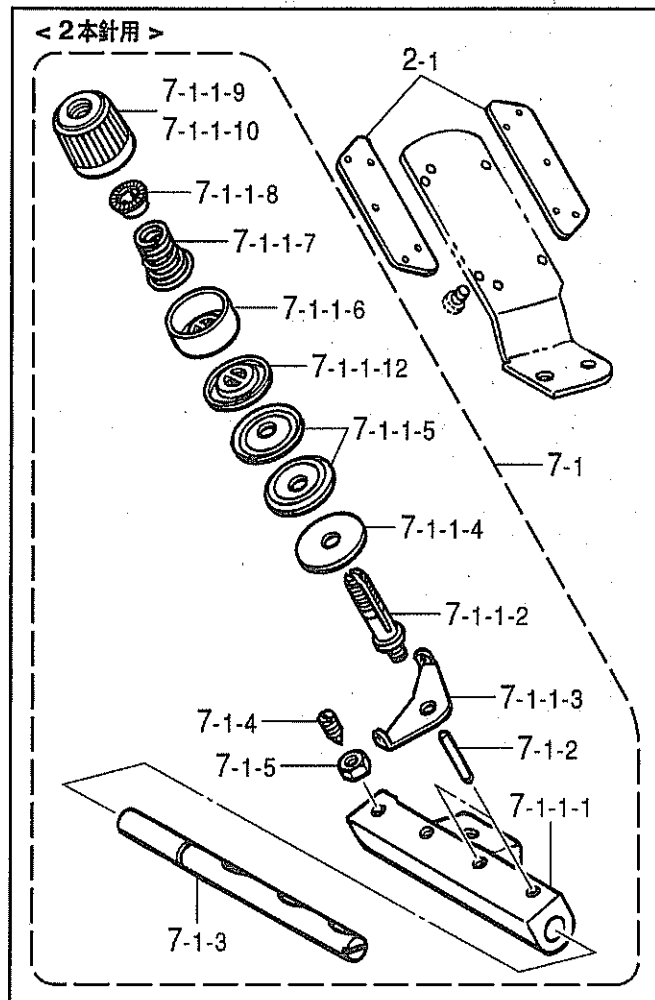
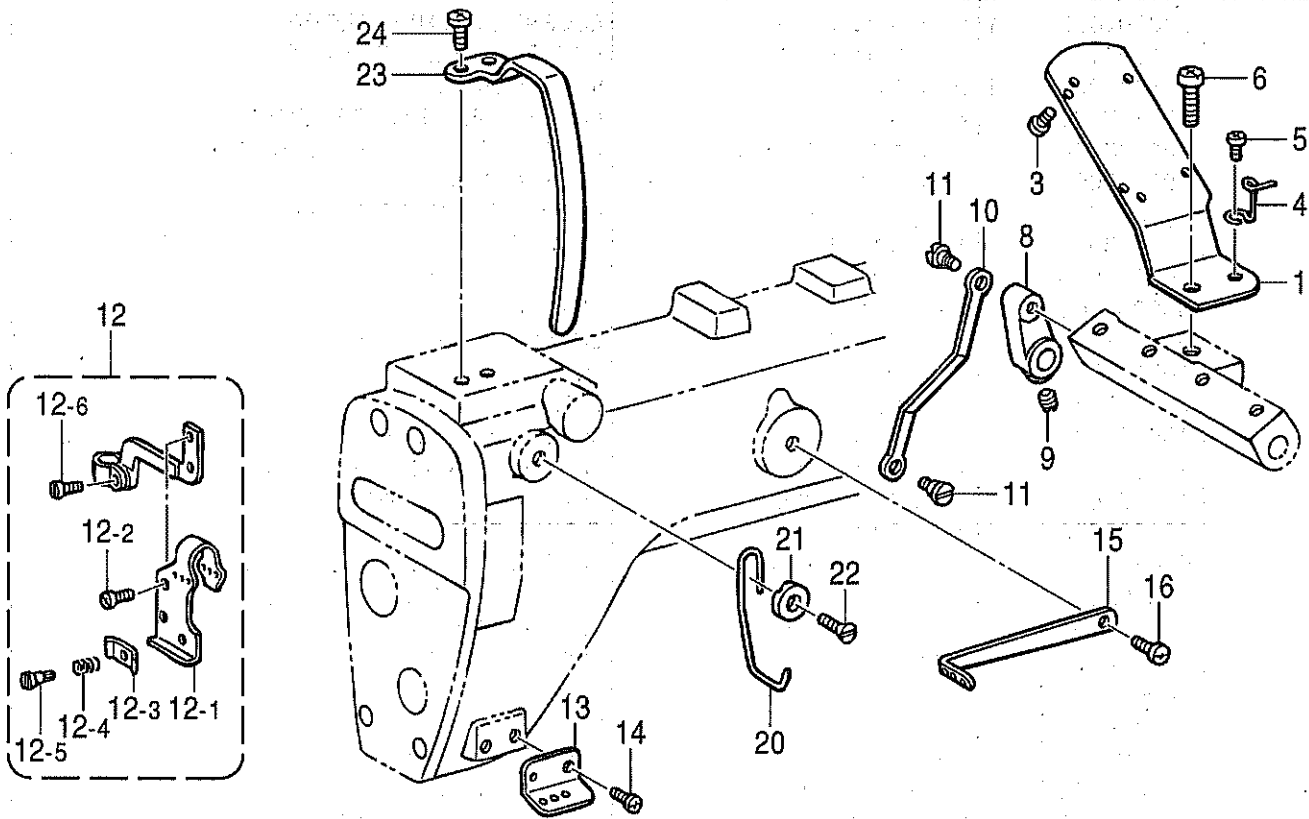

L1 . 上糸通シ関係 (9270) / Upper threading mechanism (9270)

REF.NO.	CODE	Q'TY	ヒンメイ	NAME OF PARTS	RM
1	111070109	1	ウワイトアンナイダイ	UPPER THREAD GUIDE	
3	062630412	4	ナベコ238-56X4	SCREW, PAN SM2.38-56X4	
4	105222001	1	ウワイトアンナイダイトカケ	THREAD GUIDE	
5	062670512	1	ナベコ357-40X5	SCREW, PAN SM3.57-40X5	
6	062712012	1	ナベコ476-32X20	SCREW, PAN SM4.76-32X20	
8	105235251	1	イトユルメウデ	TENSION RELEASE CRANK	
9	151602002	1	トメネジ4.37	SET SCREW, SM4.37	
10	105236001	1	イトユルメレンカン	TENSION RELEASE CONNECTING ROD	
11	105237002	2	ダンネジ3.57	SHOULDER SCREW, SM3.57	
12	S40310001	1	ウワイトテンビンクミ	UPPER THREAD TAKE-UP ASSY	
12-1	S40312001	1	ウワイトテンビンイトトオシ	UPPER THREAD GUIDE	
12-2	062660512	2	ナベコ318-40X5	SCREW, PAN SM3.18X5	
12-3	105243001	1	ウワイトテンビンイトオサエ	UPPER THREAD TAKE-UP HOLDER	
12-4	105244000	1	テンビンイトオサエバネ	SPRING	
12-5	105245001	1	ダンネジ2.38	SHOULDER SCREW, SM2.38	
12-6	100064005	1	シメネジ3.57	SCREW, SM3.57	
13	S40313051	1	ハリイトイトアンナイ	UPPER THREAD GUIDE	
14	062670712	1	ナベコ357-40X7	SCREW, PAN SM3.57-40X7	
15	111077001	1	イトユルメレバー	TENSION RELEASE LEVER	
16	060670812	1	バインド357-40X8	SCREW, BIND SM3.57-40X8	
20	111083001	1	ウワイトテンビンイトカケ	UPPER THREAD TAKE-UP GUIDE	
21	111188001	1	イトアンナイザガネ	WASHER	
22	111084001	1	サラネジ3.57	SCREW, FLAT SM3.57	
23	S37186001	1	テンビンカバー	THREAD TAKE-UP COVER	
24	062710812	2	ナベコ476-32X8	SCREW, PAN SM4.76-32X8	

2-1	105221001	2	<2本針用> ミツメイトカケ	<FOR TWIN NEEDLE> THREAD RETAINER	
7-1	S43446009	1	ウワイトチヨウシクミ	UPPER THREAD REGULATOR ASSY	
7-1-1-1	111075059	1	ウワイトチヨウシボウダイ	UPPER THREAD TENSION BRACKET	
7-1-1-2	145440001	2	イトチヨウシボウ	TENSION STUD	
7-1-1-3	110813001	2	ハリイトアンナイ	NEEDLE THREAD GUIDE	
7-1-1-4	110832009	2	イトチヨウシサラフェルト	TENSION DISC FELT	
7-1-1-5	145446001	4	イトチヨウシサラ	TENSION DISC	
7-1-1-6	144103009	2	イトチヨウシサラオサエ	TENSION DISC PRESSER	
7-1-1-7	144104001	2	ハリイトチヨウシバネ	THREAD TENSION ADJUST SPRING	
7-1-1-8	S30564000	2	チヨウシバネウエザガネ	TENSION SPRING WASHER	
7-1-1-9	S30565002	1	イトチヨウシナツトミドリ	TENSION NUT, GREEN	
7-1-1-10	S30565003	1	イトチヨウシナツトアカ	TENSION NUT, RED	
7-1-1-12	159805001	2	イトチヨウシサラオサエ	TENSION DISC PRESSER	
7-1-2	105231000	2	イトユルメピン	PIN	
7-1-3	111076151	1	イトユルメジク	TENSION RELEASE SHAFT	
7-1-4	105233002	1	トメネジ4.37	SET SCREW, SM4.37	
7-1-5	105234003	1	ナツト4.37	NUT, SM4.37	

2-2	105221001	3	<3本針用> ミツメイトカケ	<FOR THREE NEEDLE> THREAD RETAINER	
7-2	S43448009	1	ウワイトチヨウシクミ	UPPER THREAD REGULATOR ASSY	
7-2-1-1	111075059	1	ウワイトチヨウシボウダイ	UPPER THREAD TENSION BRACKET	
7-2-1-2	145440001	3	イトチヨウシボウ	TENSION STUD	
7-2-1-3	110813001	3	ハリイトアンナイ	NEEDLE THREAD GUIDE	
7-2-1-4	110832009	3	イトチヨウシサラフェルト	TENSION DISC FELT	
7-2-1-5	145446001	6	イトチヨウシサラ	TENSION DISC	
7-2-1-6	144103009	3	イトチヨウシサラオサエ	TENSION DISC PRESSER	
7-2-1-7	144104001	3	ハリイトチヨウシバネ	THREAD TENSION ADJUST SPRING	
7-2-1-8	S30564000	3	チヨウシバネウエザガネ	TENSION SPRING WASHER	
7-2-1-9	S30565002	1	イトチヨウシナツトミドリ	TENSION NUT, GREEN	

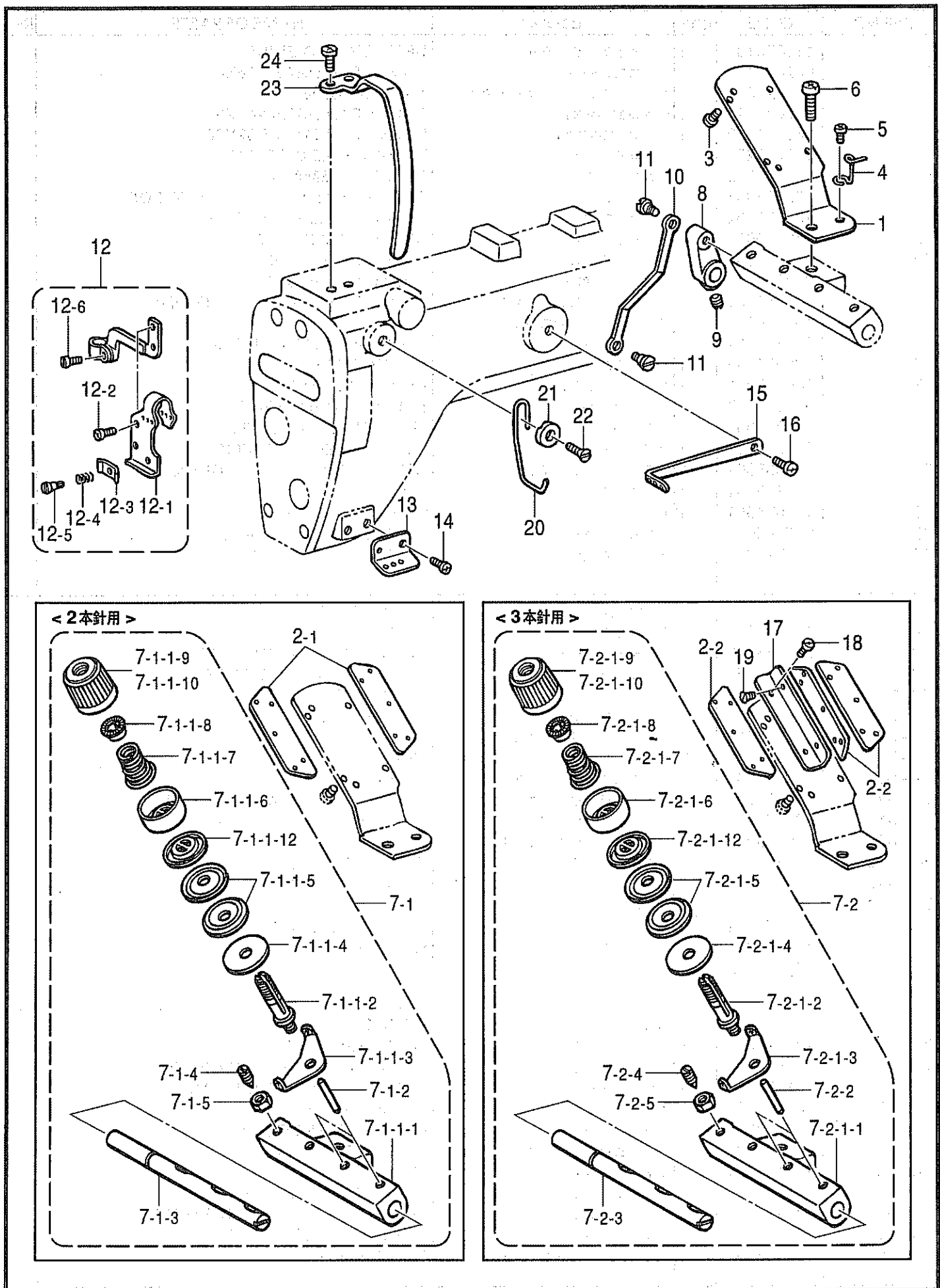

L1. 上糸通シ関係 (9270) / Upper threading mechanism (9270)

REF.NO.	CODE	Q'TY	ヒンメイ	NAME OF PARTS	RM
7-2-1-10	S30565003	1	イトチヨウシナツトアカ	TENSION NUT, RED	
7-2-1-11	S30565004	1	イトチヨウシナツトキイ	TENSION NUT, YELLOW	
7-2-1-12	159805001	3	イトチヨウシサラオサエ	TENSION DISC PRESSER	
7-2-2	105231000	3	イトユルメピン	PIN	
7-2-3	111076151	1	イトユルメジク	TENSION RELEASE SHAFT	
7-2-4	105233002	1	トメネジ4.37	SET SCREW, SM4.37	
7-2-5	105234003	1	ナツト4.37	NUT, SM4.37	
17	111072009	1	ミツメイトアンナイトリツケイタ	THREAD GUIDE SET PLATE	
18	062630412	2	ナベコ238-56X4	SCREW, PAN SM2.38-56X4	
19	111073001	2	サラネジ2.38	SCREW, FLAT SM2.38	

L2. 上糸通シ関係 (9280) / Upper threading mechanism (9280)

REF.NO.	CODE	Q'TY	品名	NAME OF PARTS	RM
1	111070109	1	ウワイトアンナイダイ	UPPER THREAD GUIDE	
3	062630412	4	ナベコ238-56X4	SCREW, PAN SM2.38-56X4	
4	105222001	1	ウワイトアンナイダイイトカケ	THREAD GUIDE	
5	062670512	1	ナベコ357-40X5	SCREW, PAN SM3.57-40X5	
6	062712012	1	ナベコ476-32X20	SCREW, PAN SM4.76-32X20	
8	105235251	1	イトユルメウデ	TENSION RELEASE CRANK	
9	151602002	1	トメネジ4.37	SET SCREW, SM4.37	
10	105236001	1	イトユルメレンカン	TENSION RELEASE CONNECTING ROD	
11	105237002	2	ダンネジ3.57	SHOULDER SCREW, SM3.57	
12	S40310001	1	ウワイトテンピンクミ	UPPER THREAD TAKE-UP ASSY	
12-1	S40312001	1	ウワイトテンピンイトトオシ	UPPER THREAD GUIDE	
12-2	062660512	2	ナベコネジ318-40X5	SCREW, PAN SM3.18-40X5	
12-3	105243001	1	ウワイトテンピンイトオサエ	UPPER THREAD TAKE-UP HOLDER	
12-4	105244000	1	テンピンイトオサエバネ	SPRING	
12-5	105245001	1	ダンネジ2.38	SHOULDER SCREW, SM2.38	
12-6	100064005	1	シメネジ3.57	SCREW, SM3.57	
13	S40313051	1	ハリイトイトアンナイ	UPPER THREAD GUIDE	
14	062670712	1	ナベコ357-40X7	SCREW, PAN SM3.57-40X7	
18	111077001	1	イトユルメレバー	TENSION RELEASE LEVER	
19	060670612	1	バインド357-40X6	SCREW, BIND SM3.57-40X6	
20	111078051	1	イトユルメレバージク	TENSION RELEASE LEVER SHAFT	
21	111506101	1	イトユルメレンカンクミ	T/RELEASE CONNECTING ROD ASSY	
21-1	111079001	1	イトユルメレンカン	TENSION RELEASE CONNECTING ROD	
21-2	100064005	1	シメネジ3.57	SCREW, SM3.57	
21-3	149011051	1	イトユルメリンク	TENSION RELEASE LINK	
21-4	115132002	1	ダンネジ4.76	SHOULDER SCREW, M4.76	
21-5	111082051	1	イトユルメスタツド	TENSION RELEASE STUD	
22	013760610	1	トメネジ5.95クボミ	SET SCREW, (CP) SM5.95	
23	111083001	1	ウワイトテンピンイトカケ	UPPER THREAD TAKE-UP GUIDE	
24	111188001	1	イトアンナイザガネ	WASHER	
25	111084001	1	サラネジ3.57	SCREW, FLAT SM3.57	
26	111089001	1	ウワイトシメチヨウシダイ	UPPER THREAD TENSION BRACKET	
27	105073001	1	アタマツキトメネジ5.95	SET SCREW, SOCKET SM5.95	
28	111189001	1	ウワイトシメボウクミ	UPPER THREAD STUD ASSY	
29	111093001	1	ウワイトシメオシバネ	SPRING	
30	105277001	4	シタイトチヨウシイタ	LOWER THREAD TENSION PLATE	
31	100645003	1	ザガネ	WASHER	
32	105234003	1	ナツト4.37	NUT, SM4.37	
33	181060001	1	ウワイトシメカムネジツキ	UPPER THREAD CAM WITH SCREW	
33-1	100058003	2	トメネジ5.95	SET SCREW, SM5.95	
34	S37186001	1	テンピンカバー	THREAD TAKE-UP COVER	
35	062710812	2	ナベコ476-32X8	SCREW, PAN SM4.76-32X8	
2-1	105221001	2	<2本針用> ミツメイトカケ	<FOR TWIN NEEDLE> THREAD RETAINER	
7-1	S41316009	1	ウワイトチヨウシクミ	UPPER THREAD REGULATOR ASSY	
7-1-1-1	111075059	1	ウワイトチヨウシボウダイ	UPPER THREAD TENSION BRACKET	
7-1-1-2	145440001	2	イトチヨウシボウ	TENSION STUD	
7-1-1-3	110813001	2	ハリイトアンナイ	NEEDLE THREAD GUIDE	
7-1-1-4	110832009	2	イトチヨウシサラフェルト	TENSION DISC FELT	
7-1-1-5	145446001	4	イトチヨウシサラ	TENSION DISC	
7-1-1-6	144103009	2	イトチヨウシサラオサエ	TENSION DISC PRESSER	
7-1-1-7	148851001	2	ハリイトチヨウシバネ	THREAD TENSION ADJUST SPRING	
7-1-1-8	S30564000	2	チヨウシバネウエザガネ	TENSION SPRING WASHER	
7-1-1-9	S30565002	1	イトチヨウシナツトミドリ	TENSION NUT, GREEN	
7-1-1-10	S30565003	1	イトチヨウシナツトアカ	TENSION NUT, RED	
7-1-1-12	159805001	2	イトチヨウシサラオサエ	TENSION DISC PRESSER	
7-1-2	105231000	2	イトユルメピン	PIN	

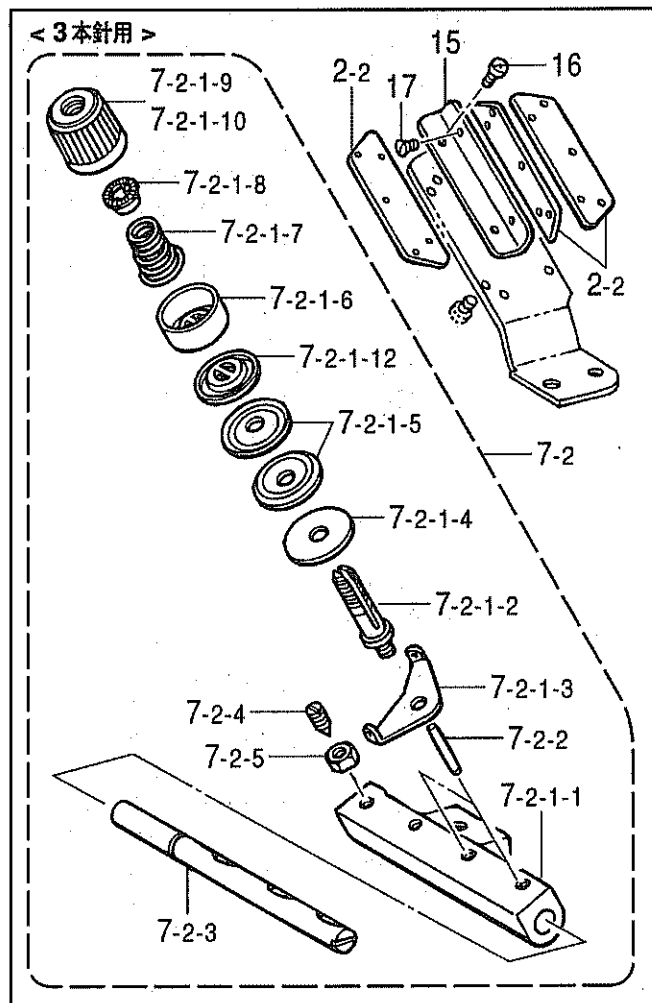
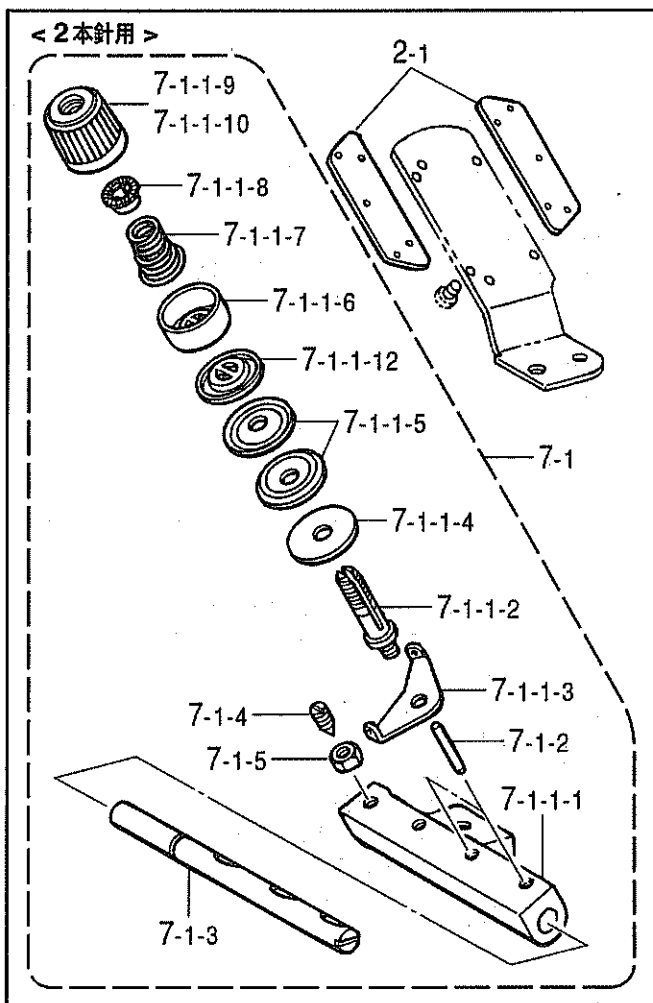
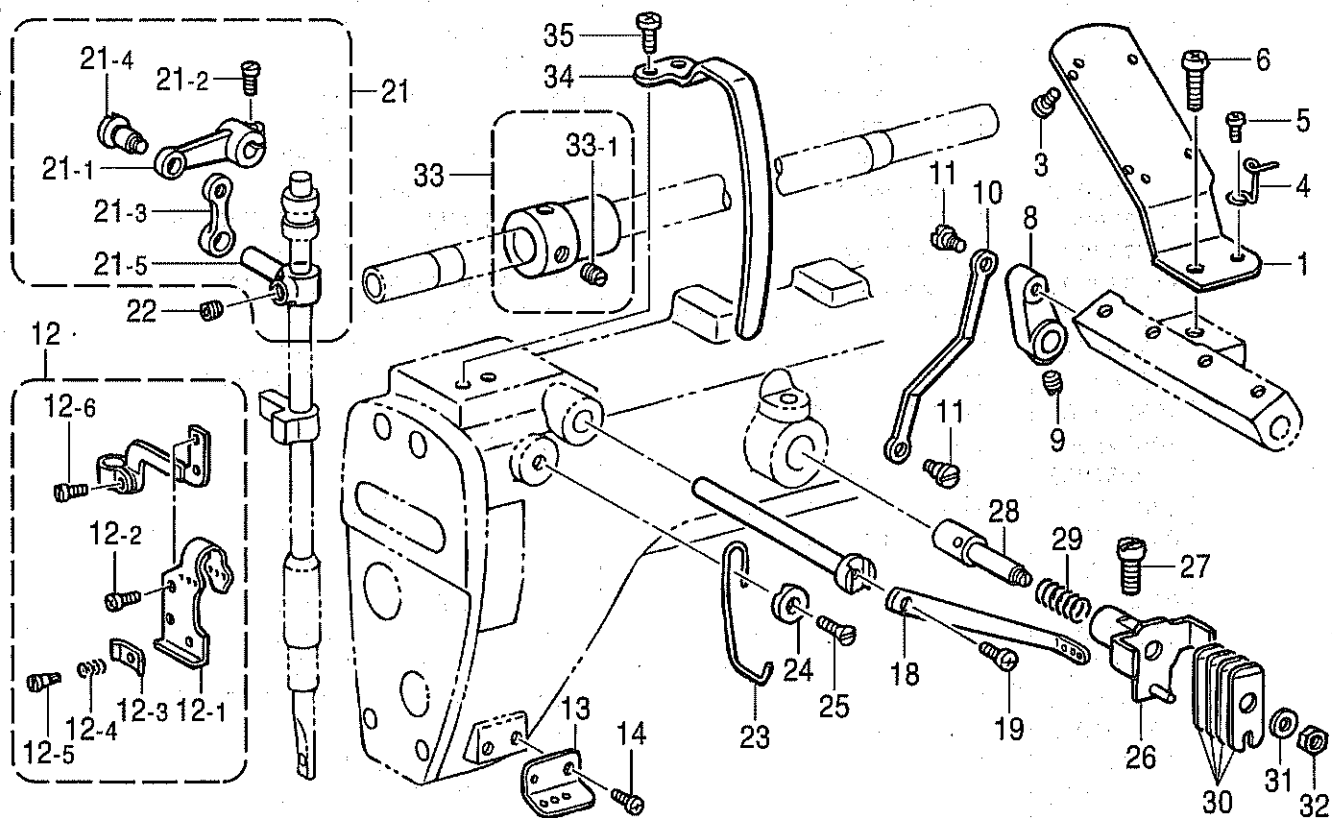

L2 . 上糸通シ関係 (9280) / Upper threading mechanism (9280)

REF.NO.	CODE	Q'TY	ヒンメイ	NAME OF PARTS	RM
7-1-3	111076151	1	イトユルメジク	TENSION RELEASE SHAFT	
7-1-4	105233002	1	トメネジ4.37	SET SCREW, SM4.37	
7-1-5	105234003	1	ナツト4.37	NUT, SM4.37	

			<3本針用>	<FOR THREE NEEDLE>	
2-2	105221001	3	ミツメイトカケ	THREAD RETAINER	
7-2	S41318009	1	ウワイトチヨウシクミ	UPPER THREAD REGULATOR ASSY	
7-2-1-1	111075059	1	ウワイトチヨウシボウダイ	UPPER THREAD TENSION BRACKET	
7-2-1-2	145440001	3	イトチヨウシボウ	TENSION STUD	
7-2-1-3	110813001	3	ハリイトアンナイ	NEEDLE THREAD GUIDE	
7-2-1-4	110832009	3	イトチヨウシサラフェルト	TENSION DISC FELT	
7-2-1-5	145446001	6	イトチヨウシサラ	TENSION DISC	
7-2-1-6	144103009	3	イトチヨウシサラオサエ	TENSION DISC PRESSER	
7-2-1-7	148851001	3	ハリイトチヨウシバネ	THREAD TENSION ADJUST SPRING	
7-2-1-8	S30564000	3	チヨウシバネウエザガネ	TENSION SPRING WASHER	
7-2-1-9	S30565002	1	イトチヨウシナツトミドリ	TENSION NUT, GREEN	
7-2-1-10	S30565003	1	イトチヨウシナツトアカ	TENSION NUT, RED	
7-2-1-11	S30565004	1	イトチヨウシナツトキイ	TENSION NUT, YELLOW	
7-2-1-12	159805001	3	イトチヨウシサラオサエ	TENSION DISC PRESSER	
7-2-2	105231000	3	イトユルメピン	PIN	
7-2-3	111076151	1	イトユルメジク	TENSION RELEASE SHAFT	
7-2-4	105233002	1	トメネジ4.37	SET SCREW, SM4.37	
7-2-5	105234003	1	ナツト4.37	NUT, SM4.37	
15	111072009	1	ミツメイトアンナイトリツケイタ	THREAD GUIDE SET PLATE	
16	062630412	2	ナベコ238-56X4	SCREW, PAN SM2.38-56X4	
17	111073001	2	サラネジ2.38	SCREW, FLAT SM2.38	

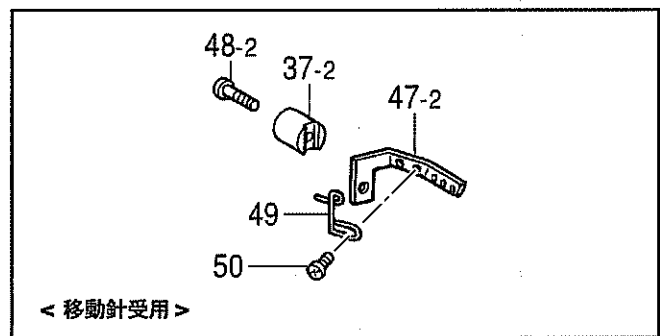
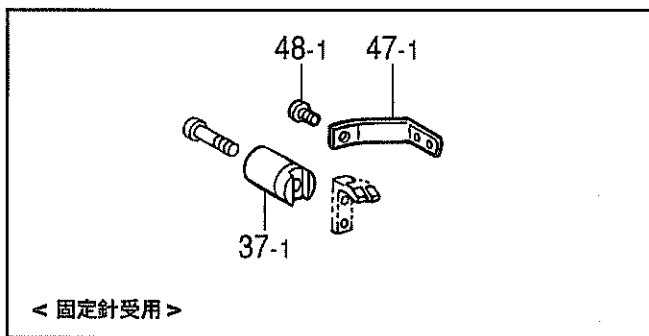
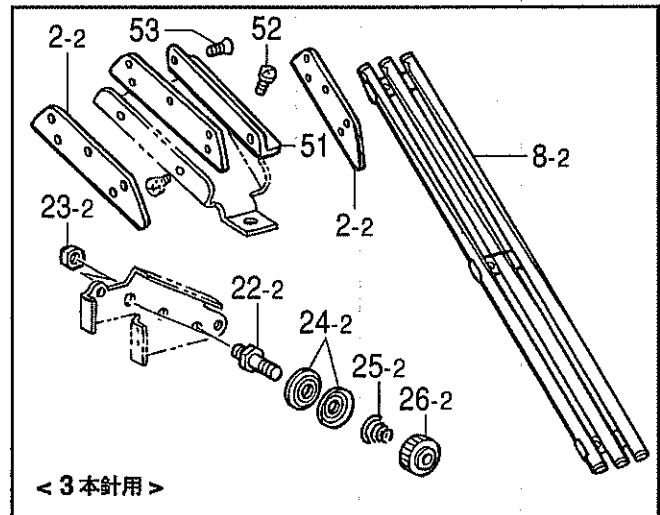
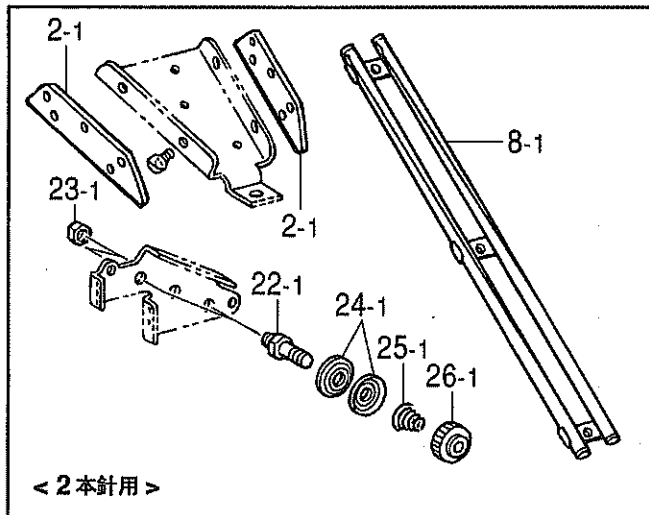
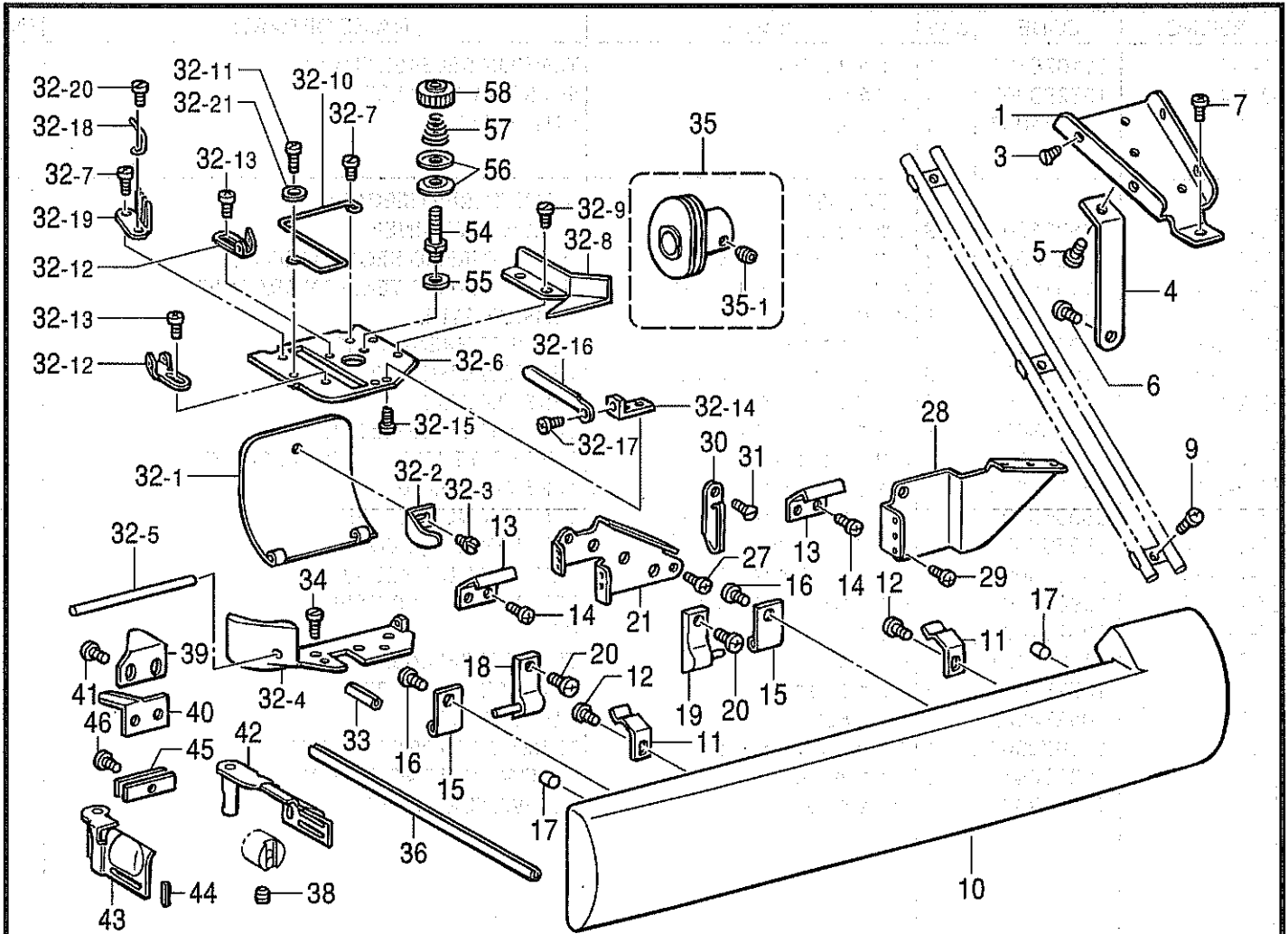

M1. 下糸通シ関係 (9270) / Lower threading mechanism (9270)

REF.NO.	CODE	Q'TY	ヒンメイ	NAME OF PARTS	RM
1	111095009	1	シタイトアンナイダイ	LOWER THREAD GUIDE RETAINER	
3	111073001	4	サラネジ2.38	SCREW, FLAT SM2.38	
4	111096009	1	シタイトアンナイササエ	LOWER THREAD GUIDE SUPPORT	
5	062670412	1	ナベコ357-40X4	SCREW, PAN SM3.57-40X4	
6	062670512	1	ナベコ357-40X5	SCREW, PAN SM3.57-40X5	
7	062671012	1	ナベコ357-40X10	SCREW, PAN SM3.57-40X10	
9	062670812	3	ナベコ3.57-40X8	SCREW, PAN SM3.57-40X8	
10	540319001	1	マエカバー	FRONT COVER	
11	540320051	2	マエカバートメバネ	FRONT COVER SPRING	
12	060670512	2	バインド357-40X5	SCREW, BIND SM3.57-40X5	
13	540321051	2	マエカバーフック	FRONT COVER HOOK	
14	062670612	4	ナベコ357-40X6	SCREW, PAN SM3.57-40X6	
15	540322051	2	マエカバーヒンジ	HINGE	
16	062670612	2	ナベコ357-40X6	SCREW, PAN SM3.57-40X6	
17	142274009	2	ゴムセン4.2	RUBBER CAP, 4.2	
18	105257009	1	アンナイフタヒンジLクミ	L/THREAD GUIDE HINGE ASSY, L	
19	105260009	1	アンナイフタヒンジRクミ	L/THREAD GUIDE HINGE ASSY, R	
20	062671012	2	ナベコ357-40X10	SCREW, PAN SM3.57-40X10	
21	540323001	1	シタイトチヨウシダイ	LOWER THREAD TENSION BRACKET	
27	062670612	2	ナベコ357-40X6	SCREW, PAN SM3.57-40X6	
28	540325001	1	シタイトアンナイ	LOWER THREAD GUIDE	
29	062670612	2	ナベコ357-40X6	SCREW, PAN SM3.57-40X6	
30	112658001	1	アームイトアンナイM	ARM THREAD GUIDE, M	
31	108960002	1	サラネジ3.57	SCREW, FLAT SM3.57	
32	540266051	1	シタイトテンビンダイクミ	LOWER THREAD TAKE-UP BRACKET	
32-1	105280009	1	シタイトテンビンフタ	L/THREAD TAKE-UP LEVER COVER	
32-2	105281001	1	テンビンフタトメイタバネ	SPRING, PLATE	
32-3	122771002	1	シメネジ2.38	SCREW, SM2.38	
32-4	105284101	1	シタイトテンビンダイササエ	L/TR. TAKE-UP LEVER BRACKET	
32-5	105285000	1	シタイトテンビンフタジク	L/TR. TAKE-UP LEVER COV. SHAFT	
32-6	540326051	1	シタイトテンビンダイ	L/TR. TAKE-UP LEVER BRACKET	
32-7	062670612	2	ナベコ357-40X6	SCREW, PAN SM3.57-40X6	
32-8	105287001	1	テンビンダイアンナイイタ	GUIDE PLATE	
32-9	105288001	2	シメネジ2.38	SCREW, SM2.38	
32-10	540327051	1	テンビンイトウケ	LOWER THREAD GUIDE	
32-11	060660416	1	バインド318-40X4	SCREW, BIND SM3.18-40X4	
32-12	540795101	2	DLテンビンイトアンナイ	LOWER THREAD GUIDE	
32-13	060660416	2	バインド318-40X4	SCREW, BIND SM3.18-40X4	
32-14	540328051	1	イトオサエドダイ	THREAD RELEASE BASE	
32-15	062660412	2	ナベコ318-40X4	SCREW, PAN SM3.18-40X4	
32-16	540329051	1	テンビンイトオサエ	LOWER THREAD PRESSER	
32-17	062660412	1	ナベコ318-40X4	SCREW, PAN SM3.18-40X4	
32-18	105296001	1	テンビンダイイトカケ	THREAD GUIDE	
32-19	111112001	1	シタイトイトアンナイイタ	LOWER THREAD GUIDE PLATE	
32-20	105288001	1	シメネジ2.38	SCREW, SM2.38	
32-21	026030136	1	ヒラザガネコガタ3	WASHER, PLAIN S 3	
33	047501242	1	スプリングピンAW5	PIN, SPRING ROLL AW5	
34	100064005	2	シメネジ3.57	SCREW, SM3.57	
35	540330051	1	シタイトテンビンネジツクM	LOWER THREAD TAKE-UP W/S, M	
35-1	014680422	2	アチトメネジ4.37クボミ	SET SCREW, SOCKET (CP) SM4.37	
36	105300101	1	シタイトオクリダシアンナイ	LOWER THREAD FEED BAR GUIDE	
38	013760610	1	トメネジ5.95クボミ	SET SCREW, (CP) SM5.95	
39	111113101	1	イトキリアンナイイタ	THREAD TRIMMER GUIDE PLATE	
40	111114101	1	イトキリ	THREAD TRIMMER	
41	062670612	2	ナベコ357-40X6	SCREW, PAN SM3.57-40X6	
42	540335051	1	ルーパガワフタRA	LOOPER COVER, RA	
43	540338051	1	ルーパガワフタLA	LOOPER COVER, LA	
44	047200842	1	スプリングピンAW2	PIN, SPRING ROLL AW2	
45	540799051	2	ルーパガワフタトメバネ	SPRING	

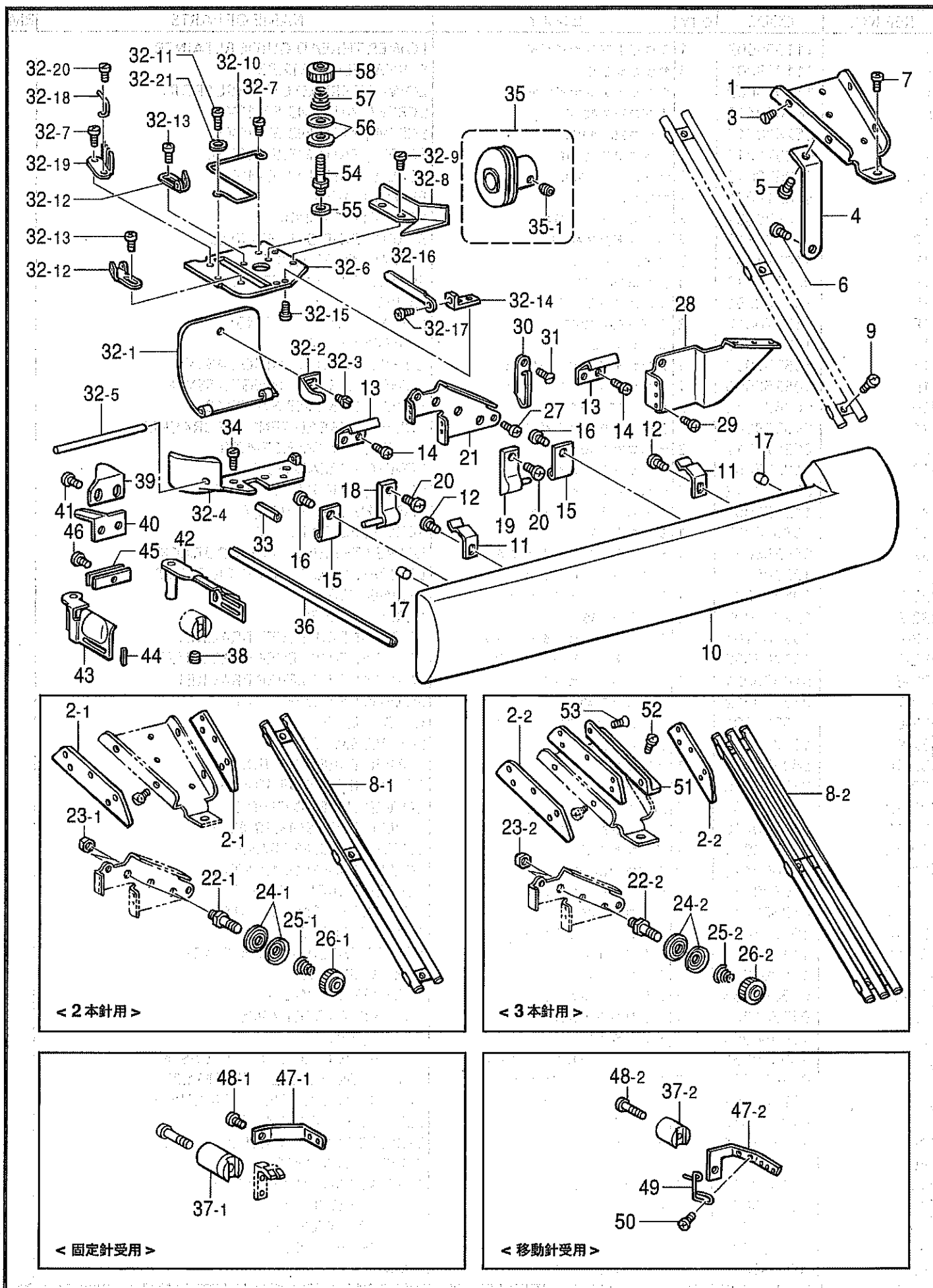

M1. 下糸通シ関係 (9270) / Lower threading mechanism (9270)

REF.NO.	CODE	Q'TY	ヒンメイ	NAME OF PARTS	RM
46	062670712	1	ナベコ357-40X7	SCREW, PAN SM3.57-40X7	
54	S08987001	1	イトチヨウシボウ	THREAD TENSION CONTROL STUD	
55	146354001	1	ザガネ	WASHER, PLAIN 5	
56	144504001	2	イトアンナイサラ	THREAD GUIDE DISC	
57	S40324001	1	イトアンナイバネ	THREAD GUIDE SPRING	
58	155510001	1	イトチヨウシナツト	TENSION NUT	

2-1	105221001	2	<2本針用> ミツメイトカケ	<FOR TWIN NEEDLE> THREAD RETAINER	
8-1	105251009	1	シタイトタテアンナイクミ	INGLINED GUIDE TUBE ASSY	
22-1	S08987001	2	イトチヨウシボウ	THREAD TENSION CONTROL STUD	
23-1	021680202	2	ナツト2シユ4.37	NUT, 2 SM4.37	
24-1	144504001	4	イトアンナイサラ	THREAD GUIDE DISC	
25-1	S40324001	2	イトアンナイバネ	THREAD GUIDE SPRING	
26-1	155510001	2	イトチヨウシナツト	TENSION NUT	
2-2	105221001	3	<3本針用> ミツメイトカケ	<FOR THREE NEEDLE> THREAD RETAINER	
8-2	111097009	1	シタイトタテアンナイクミ	INGLINED GUIDE TUBE ASSY	
22-2	S08987001	3	イトチヨウシボウ	THREAD TENSION CONTROL STUD	
23-2	021680202	3	ナツト2シユ4.37	NUT, 2 SM4.37	
24-2	144504001	6	イトアンナイサラ	THREAD GUIDE DISC	
25-2	S40324001	3	イトアンナイバネ	THREAD GUIDE SPRING	
26-2	155510001	3	イトチヨウシナツト	TENSION NUT	
51	111072009	1	ミツメイトアンナイトリツケイタ	THREAD GUIDE SET PLATE	
52	062630412	2	ナベコ238-56X4	SCREW, PAN SM2.38-56X4	
53	111073001	2	サラネジ2.38	SCREW, FLAT SM2.38	

37-1	105301001	1	<固定針受用> ルーパイトアンナイダイ	<FOR "FIX NEEDLE SUPPORT"> LOOPER THREAD GUIDE BRACKET	
47-1	105304001	1	ルーパイトアンナイ	LOOPER THREAD GUIDE	
48-1	062660612	1	ナベコ318-40X6	SCREW, PAN SM3.18-40X6	
37-2	147291001	1	<移動針受用> ルーパイトアンナイダイ	<FOR "MOVEABLE NEEDLE SUPPORT"> LOOPER THREAD GUIDE BRACKET	
47-2	S16487151	1	ルーパイトアンナイ-8	LOOPER THREAD GUIDE, -8	
48-2	062671412	1	ナベコ357-40X14	SCREW, PAN SM3.57-40X14	
49	S40341001	1	ルーパイトアンナイ	LOOPER THREAD GUIDE	
50	062630412	2	ナベコ238-56X4	SCREW, PAN SM2.38-56X4	

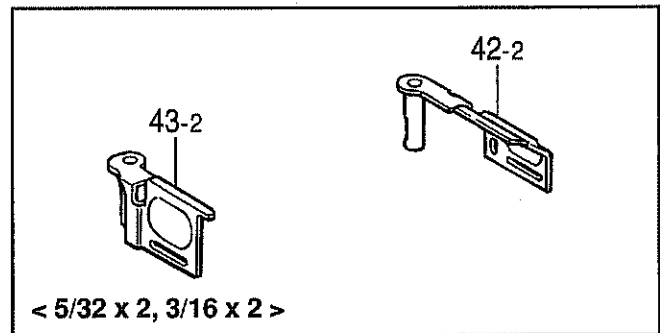
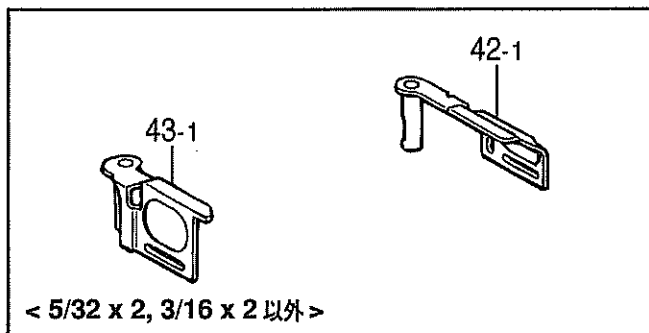
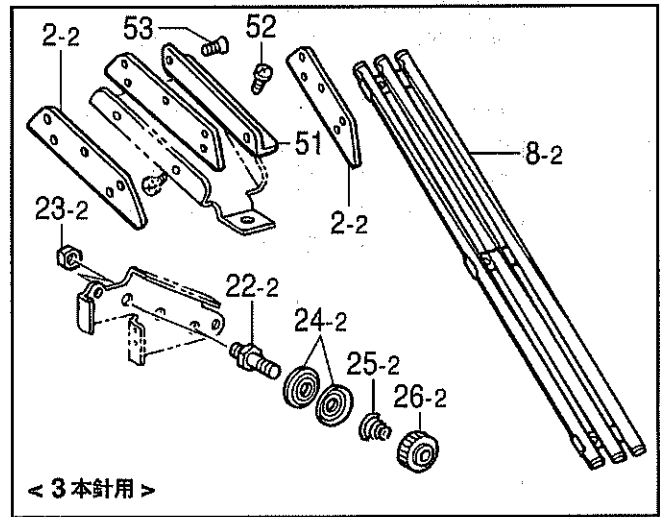
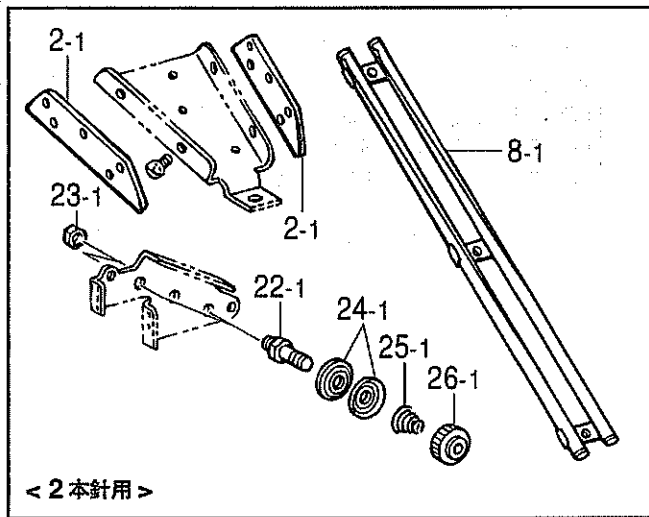
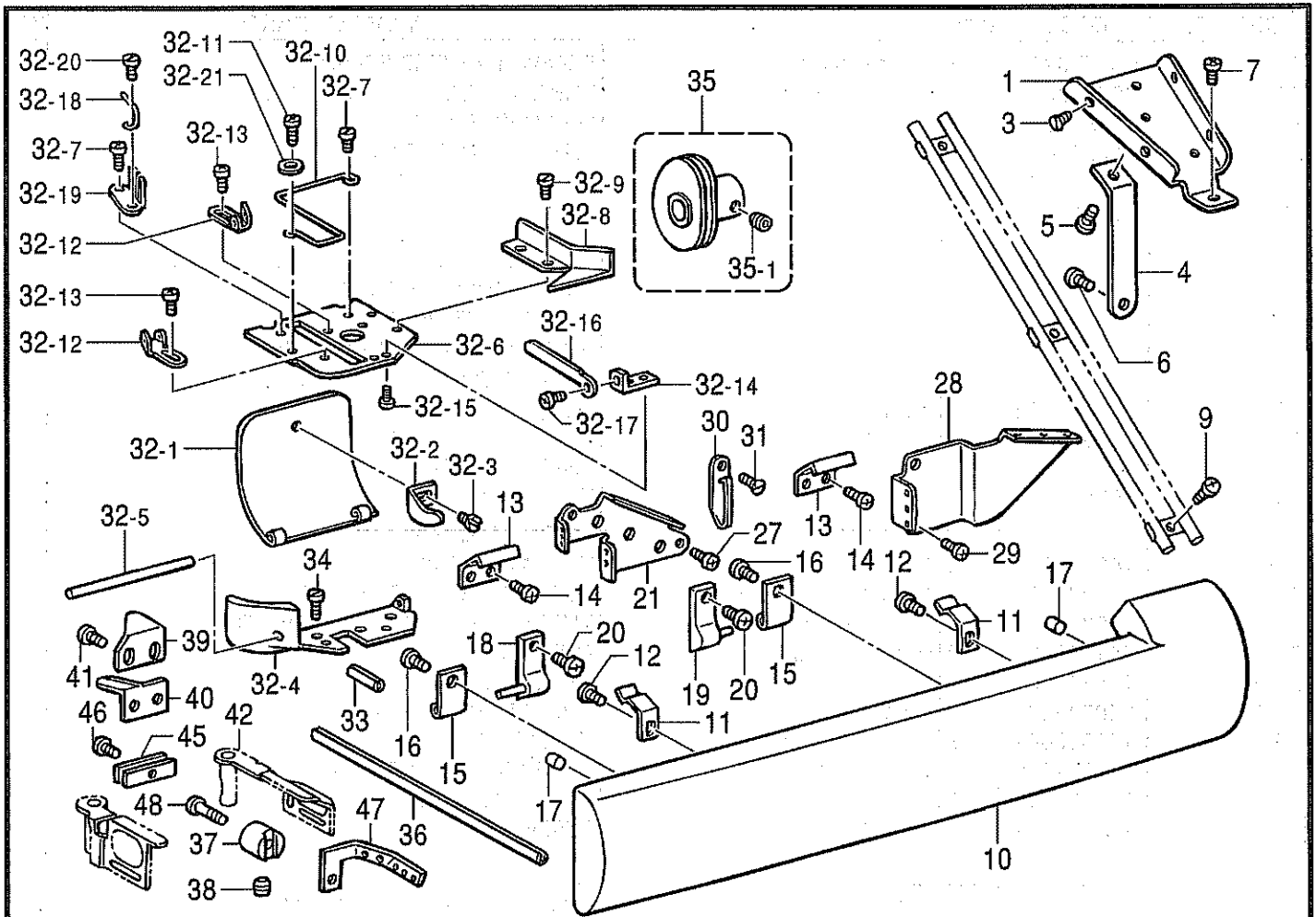

M2 . 下糸通シ関係 (9280) / Lower threading mechanism (9280)

REF.NO.	CODE	Q'TY	ヒンメイ	NAME OF PARTS	RM
1	111095009	1	シタイトアンナイダイ	LOWER THREAD GUIDE RETAINER	
3	111073001	4	サラネジ2.38	SCREW, FLAT SM2.38	
4	111096009	1	シタイトアンナイササエ	LOWER THREAD GUIDE SUPPORT	
5	062670412	1	ナベコ357-40X4	SCREW, PAN SM3.57-40X4	
6	062670512	1	ナベコ357-40X5	SCREW, PAN SM3.57-40X5	
7	062671012	1	ナベコ357-40X10	SCREW, PAN SM3.57-40X10	
9	062670812	3	ナベコ3.57-40X8	SCREW, PAN SM3.57-40X8	
10	S40319001	1	マエカバー	FRONT COVER	
11	S40320051	2	マエカバートメバネ	FONT COVER SPRING	
12	060670512	2	バインド357-40X5	SCREW, BIND SM3.57-40X5	
13	S40321051	2	マエカバーフック	FRONT COVER HOOK	
14	062670612	4	ナベコ357-40X6	SCREW, PAN SM3.57-40X6	
15	S40322051	2	マエカバーヒンジ	HINGE	
16	062670612	2	ナベコ357-40X6	SCREW, PAN SM3.57-40X6	
17	142274009	2	ゴムセン4.2	RUBBER CAP, 4.2	
18	105257009	1	アンナイフタヒンジLクミ	L/THREAD GUIDE HINGE ASSY, L	
19	105260009	1	アンナイフタヒンジRクミ	L/THREAD GUIDE HINGE ASSY, R	
20	062671012	2	ナベコ357-40X10	SCREW, PAN SM3.57-40X10	
21	S40323001	1	シタイトチヨウシダイ	LOWER THREAD TENSION BRACKET	
27	062670612	2	ナベコ357-40X6	SCREW, PAN SM3.57-40X6	
28	S40325001	1	シタイトアンナイ	LOWER THREAD GUIDE	
29	062670612	2	ナベコ357-40X6	SCREW, PAN SM3.57-40X6	
30	112658001	1	アームイトアンナイM	ARM THREAD GUIDE, M	
31	108960002	1	サラネジ3.57	SCREW, FLAT SM3.57	
32	S40266051	1	シタイトテンビンダイクミ	LOWER THREAD TAKE-UP BRACKET	
32-1	105280009	1	シタイトテンビンフタ	L/THREAD TAKE-UP LEVER COVER	
32-2	105281001	1	テンビンフタトメイタバネ	SPRING, PLATE	
32-3	122771002	1	シメネジ2.38	SCREW, SM2.38	
32-4	105284101	1	シタイトテンビンダイササエ	L/TR. TAKE-UP LEVER BRACKET	
32-5	105285000	1	シタイトテンビンフタジク	L/TR. TAKE-UP LEVER COV. SHAFT	
32-6	S40326051	1	シタイトテンビンダイ	L/TR. TAKE-UP LEVER BRACKET	
32-7	062670612	2	ナベコ357-40X6	SCREW, PAN SM3.57-40X6	
32-8	105287001	1	テンビンダイアンナイイタ	GUIDE PLATE	
32-9	105288001	2	シメネジ2.38	SCREW, SM2.38	
32-10	S40327051	1	テンビンイトウケ	LOWER THREAD GUIDE	
32-11	060660416	1	バインド318-40X4	SCREW, BIND SM3.18-40X4	
32-12	S40795101	2	DLテンビンイトアンナイ	LOWER THREAD GUIDE	
32-13	060660416	2	バインド318-40X4	SCREW, BIND SM3.18-40X4	
32-14	S40328051	1	イトオサエドダイ	THREAD RELEASE BASE	
32-15	062660412	2	ナベコ318-40X4	SCREW, PAN SM3.18-40X4	
32-16	S40329051	1	テンビンイトオサエ	LOWER THREAD PRESSER	
32-17	062660412	1	ナベコ318-40X4	SCREW, PAN SM3.18-40X4	
32-18	105296001	1	テンビンダイイトカケ	THREAD GUIDE	
32-19	111112001	1	シタイトイトアンナイイタ	LOWER THREAD GUIDE PLATE	
32-20	105288001	1	シメネジ2.38	SCREW, SM2.38	
32-21	026030136	1	ヒラザガネコガタ3	WASHER, PLAIN S 3	
33	047501242	1	スプリングピンAW5	PIN, SPRING ROLL AW5	
34	100064005	2	シメネジ3.57	SCREW, SM3.57	
35	S40342051	1	シタイトテンビンネジツキH	LOWER THREAD TAKE-UP W/S, H	
35-1	014680422	2	アナトメネジ4.37クボミ	SET SCREW, SOCKET (CP) SM4.37	
36	105300101	1	シタイトオクリダシアンナイ	LOWER THREAD FEED BAR GUIDE	
37	147291001	1	ルーパイトアンナイダイ	LOOPER THREAD GUIDE BRACKET	
38	013760610	1	トメネジ5.95クボミ	SET SCREW, (CP) SM5.95	
39	111113101	1	イトキリアンナイイタ	THREAD TRIMMER GUIDE PLATE	
40	111114101	1	イトクリ	THREAD TRIMMER	
41	062670612	2	ナベコ357-40X6	SCREW, PAN SM3.57-40X6	
42	S40335051	1	ルーパガワフタRA	LOOPER COVER, RA	
43	S40338051	1	ルーパガワフタLA	LOOPER COVER, LA	

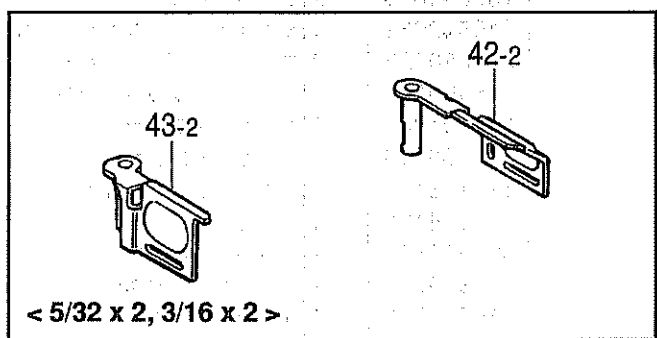
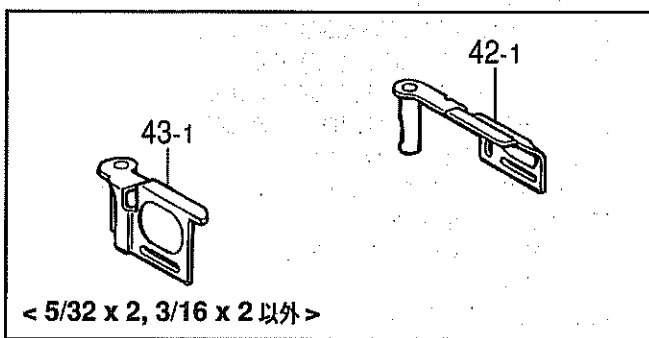
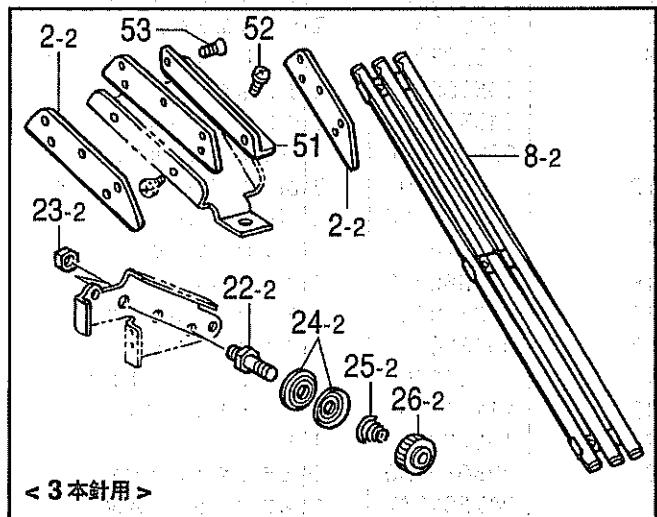
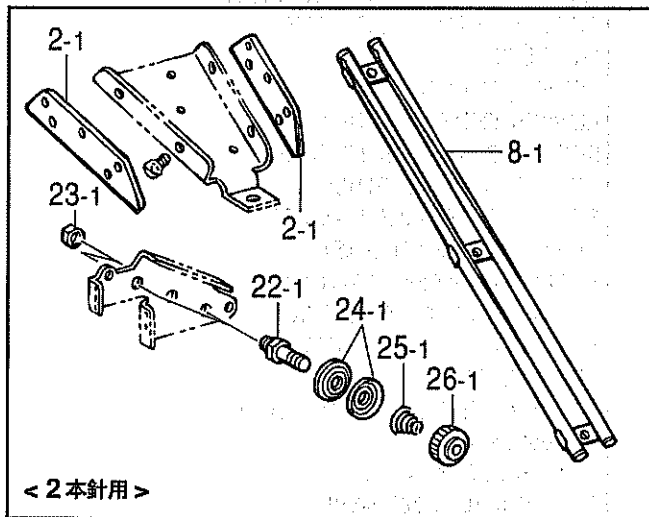
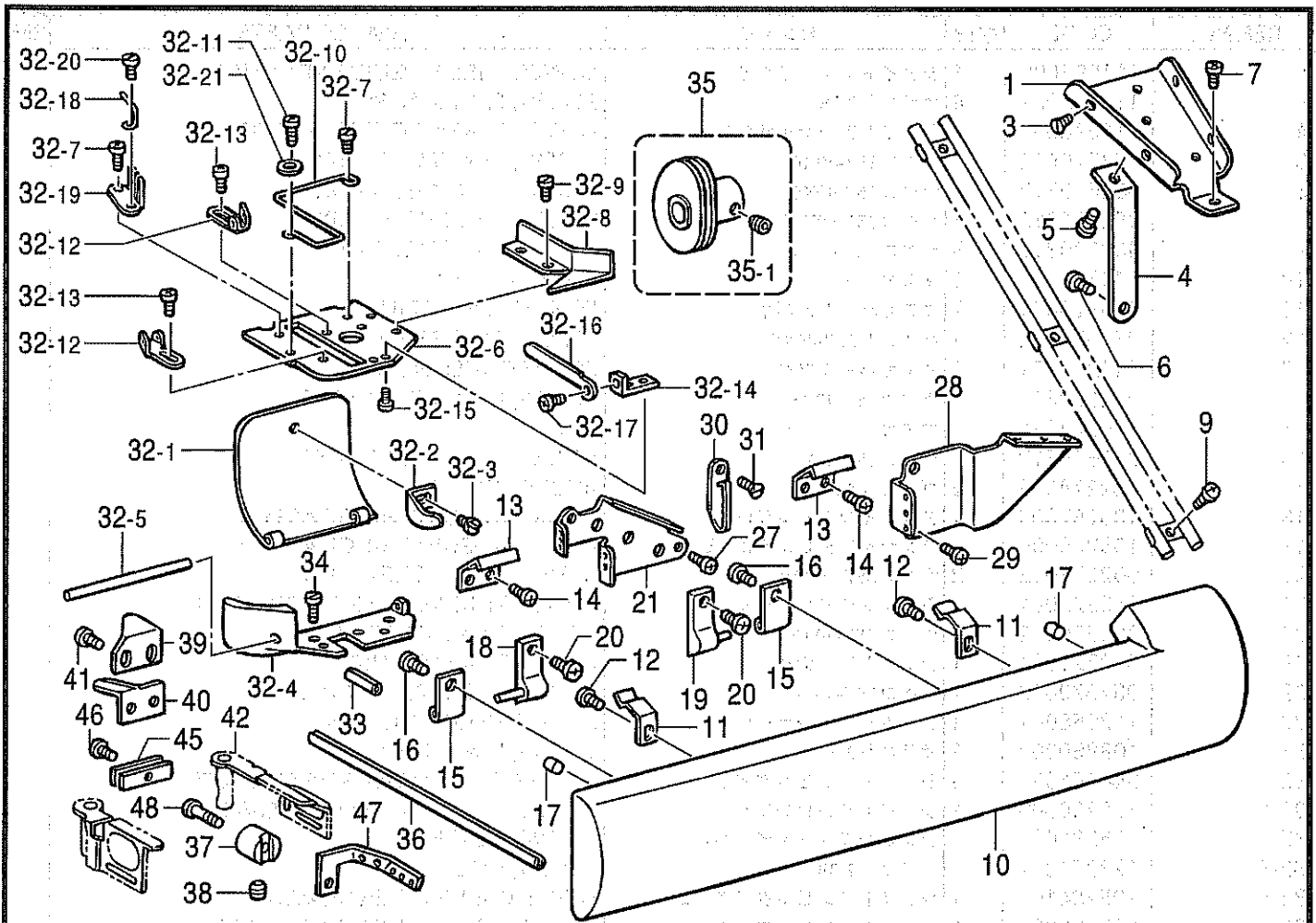

REF.NO.	CODE	Q'TY	ヒンメイ	NAME OF PARTS	RM
45	S40799051	2	ルーパガワフタトメバネ	SPRING	
48	062671412	1	ナベコ357-40X14	SCREW, PAN SM3.57-40X14	
<hr/>					
8-1	105251009	1	<2本針用> シタイトタテアンナイクミ	<FOR TWIN NEEDLE> INGLINED GUIDE TUBE ASSY	
22-1	S08987001	2	イトチヨウシボウ	THREAD TENSION CONTROL STUD	
23-1	021680202	2	ナツト2シユ4.37	NUT, 2 SM4.37	
24-1	144504001	4	イトアンナイサラ	THREAD GUIDE DISC	
25-1	S40324001	2	イトアンナイバネ	THREAD GUIDE SPRING	
26-1	155510001	2	イトチヨウシナツト	TENSION NUT	
8-2	111097009	1	<3本針用> シタイトタテアンナイクミ	<FOR THREE NEEDLE> INGLINED GUIDE TUBE ASSY	
22-2	S08987001	3	イトチヨウシボウ	THREAD TENSION CONTROL STUD	
23-2	021680202	3	ナツト2シユ4.37	NUT, 2 SM4.37	
24-2	144504001	6	イトアンナイサラ	THREAD GUIDE DISC	
25-2	S40324001	3	イトアンナイバネ	THREAD GUIDE SPRING	
26-2	155510001	3	イトチヨウシナツト	TENSION NUT	
51	111072009	1	ミツメイトアンナイトリツケイタ	THREAD GUIDE SET PLATE	
52	062630412	2	ナベコ238-56X4	SCREW, PAN SM2.38-56X4	
53	111073001	2	サラネジ2.38	SCREW, FLAT SM2.38	
<hr/>					
42-1	S40336051	1	<5/32X2, 3/16X2以外用> ルーパガワフタRB	<FOR WITHOUT "5/32X2, 3/16X2"> LOOPER COVER, RB	
43-1	S40339051	1	ルーパガワフタLB	LOOPER COVER, LB	
42-2	S40337051	1	<5/32X2, 3/16X2用> ルーパガワフタRC	<FOR "5/32X2, 3/16X2"> LOOPER COVER, RC	
43-2	S40340051	1	ルーパガワフタLC	LOOPER COVER, LC	

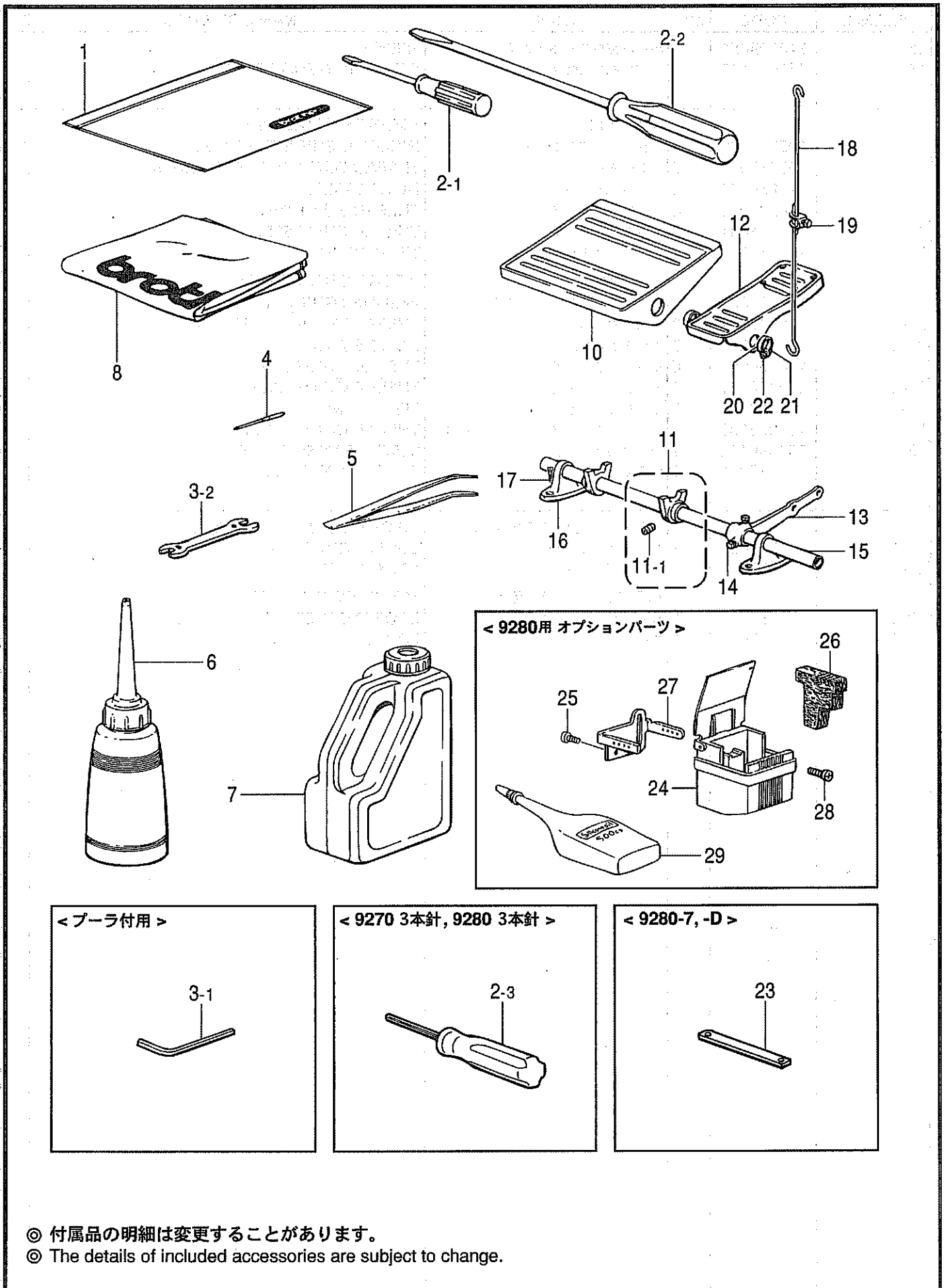

◎ 付属品の明細は変更することがあります。
 ◎ The details of included accessories are subject to change.

Z1. 付属品関係 / Accessories

REF.NO.	CODE	Q'TY	ヒンメイ	NAME OF PARTS	RM
1	122991001	1	フゾクヒンポリフクロ	ACCESSORY BAG	
2-1	105344001	1	ネジマワシ2.6X70	SCREW DRIVER, 2.6X70	
2-2	101572101	1	ネジマワシ5.5X190	SCREW DRIVER, 5.5X190	
3-2	100887001	1	スパナ8X9	WRENCH, 8X9	
5	117466000	1	ピンセット	PINCETTE	
6	114483002	1	ポリオイラークミ	OILER ASSY	
8	144228001	1	トウブカバー	HEAD COVER	
10	133636009	1	フミイタ	THREADLE PEDAL	
11	180827009	2	フミイタトメクミ	THREADLE PEDAL STOPPER ASSY	
11-1	151604001	4	トメネジ5.95	SET SCREW, SM5.95	
12	117437109	1	オサエアゲフミイタ	FOOT LIFTER PEDAL	
13	109656009	1	レンカンレバーL	CONNECTING LEVER, L	
14	100463001	2	カクボルト7.94	BOLT, SM7.94	
15	106062009	1	フミイタササエジク	THREADLE PEDAL SHAFT	
16	109657009	2	フミイタジクウケ	THREADLE PEDAL BRACKET	
17	0B1512502	4	+サラモク51X25	WOOD SCREW, FLAT M5.1X25	
18	105359001	2	レンカン	CONNECTING ROD	
19	181225001	1	レンカンダキクミ	CONNECTING ROD CLAMP ASSY	
20	116016001	2	ペタルトメ	PEDAL STOPPER	
21	021400106	2	ナツト1シユ4	NUT, 1 M4	
22	062401406	2	ナベコ4X14	SCREW, PAN M4X14	
2-3	S01943001	1	<9270 3本針, 9280 3本針> 6カクボウネジマワシ1.6	<FOR 9270 THREE NEEDLE & 9280 THREE NEEDLE> SCREW DRIVER, 1.6	
3-1	142721001	1	<プーラ付用> 6カクボウスパナ3	<WITH PULLER> HEXAGONAL WRENCH, 3	
4	※	8	<9270用> ミシンハリTVX64NY	<FOR 9270> NEEDLE, TVX64NY	
4	※	8	<9280用> ミシンハリTVX5	<FOR 9280> NEEDLE, TVX5	
23	148298001	1	<9280-7, -D用> スペーサ	<FOR 9280-7 & -D> SPACER	
24	S08758009	1	" オプション部品 "	" OPTIN PARTS "	
25	575456001	2	<9280用> ハライトレイキヤクタンククミ +ナベPタイト3X10	<FOR 9280> NEEDLE THREAD COOLER TANK ASSY TAPTITE, PAN P M3X10	
26	S08761100	1	ハライトレイキヤクフエルト	FELT	
27	S08969101	1	チユカンイトアンナイ	THREAD GUIDE	
28	060680712	2	バインド437-40X7	SCREW, BIND SM4.37X7	
29	S06704001	1	シリコンオイル	SILICONE OIL	

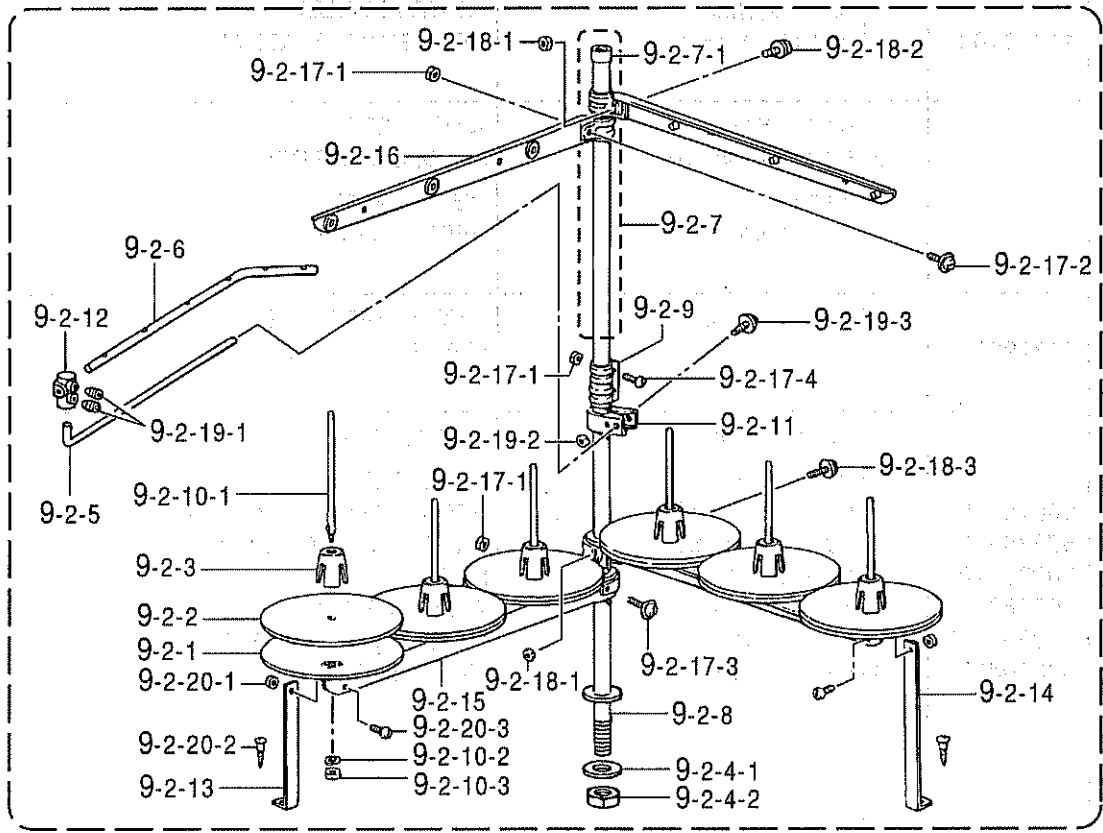
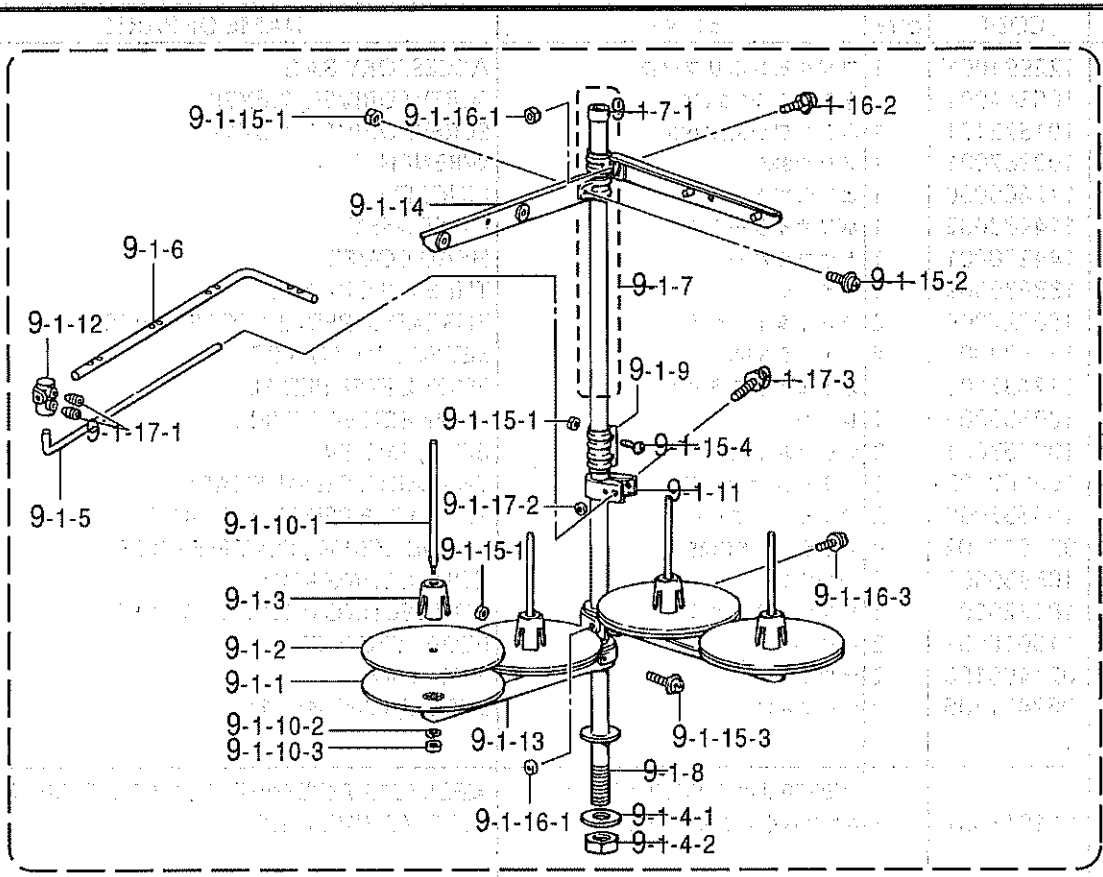

◎ 付属品の明細は変更することがあります。
 ◎ The details of included accessories are subject to change.

REF.NO.	CODE	Q'TY	ヒンメイ	NAME OF PARTS	RM
			<二本針用>	<FOR TWIN NEEDLE>	
9-1	S29854109	1	イトタテダイクミ4DTHF	COTTON STAND ASSY, 4DTHF	
9-1-1	150180001	4	ウケザラ	SPOOL STAND BASE	
9-1-2	150182000	4	スプールマット	SPOOL MAT	
9-1-3	126863001	4	スプールクツシヨン	SPOOL CUSHION	
9-1-4	S02775001	1	パイプネジセットA	PIPE SCREW SET, A	
9-1-4-1	150206002	1	ヒラザガネ16	WASHER, PLAIN 16	
9-1-4-2	S38648001	1	6カクナツトU5/8	NUT, U5/8-28	
9-1-5	S04109001	1	イトアンナイササエボウ	THREAD GUIDE SUPPORT BAR	
9-1-6	142998101	1	イトアンナイ4	THREAD GUIDE, 4	
9-1-7	S40640001	1	コラムパイプキャップツキ	COLUMN PIPE WITH CAP	
9-1-7-1	150174000	1	コラムキャップ	COLUMN CAP	
9-1-8	156112003	1	コラムパイプD	COLUMN PIPE, D	
9-1-9	150173003	1	コラムジョイント	COLUMN JOINT	
9-1-10	S21798001	4	スプールネジセット	SPOOL SCREW SET	
9-1-10-1	150179002	4	スプールジクB	SPOOL SHAFT, B	
9-1-10-2	028050246	4	バネザガネ2-5	WASHER, SPRING 2-5	
9-1-10-3	021500106	4	1シユナツト5	NUT, 1 M5	
9-1-11	150185009	1	イトアンナイホルダー	THREAD GUIDE HOLDER	
9-1-12	138843001	1	ササエボウツギテ	JOINT	
9-1-13	S02778002	2	スプールホルダー2	SPOOL HOLDER, 2	
9-1-14	S02786002	2	スレツドハンガークミ2	THREAD HANGER ASSY, 2	
9-1-15	S40641001	1	スプールジクネジセットA	SPOOL SCREW SET, A	
9-1-15-1	021500106	4	1シユナツト5	NUT, 1 M5	
9-1-15-2	S37038001	1	ナベコヒラザ5X14	SCREW, PAN (P WASHER) M5X14	
9-1-15-3	S37037001	1	ナベコヒラザ5X32	SCREW, PAN (P WASHER) M5X32	
9-1-15-4	062501406	2	ナベコ5X14	SCREW, PAN M5X14	
9-1-16	S40642001	1	スプールジクネジセットB	SPOOL SHAFT SCREW SET, B	
9-1-16-1	021500106	2	1シユナツト5	NUT, 1 M5	
9-1-16-2	S37038001	1	ナベコヒラザ5X14	SCREW, PAN (P WASHER) M5X14	
9-1-16-3	S37037001	1	ナベコヒラザ5X32	SCREW, PAN (P WASHER) M5X32	
9-1-17	S40643001	1	ホルダーツギテネジセット	HOLDER JOINT SCREW SET	
9-1-17-1	014060632	2	アナトメ6X6クボミ	SET SCREW, SOCKET (CP) M6X6	
9-1-17-2	021500106	1	1シユナツト5	NUT, 1 M5	
9-1-17-3	S37037001	1	ナベコヒラザ5X32	SCREW, PAN (P WASHER) M5X32	

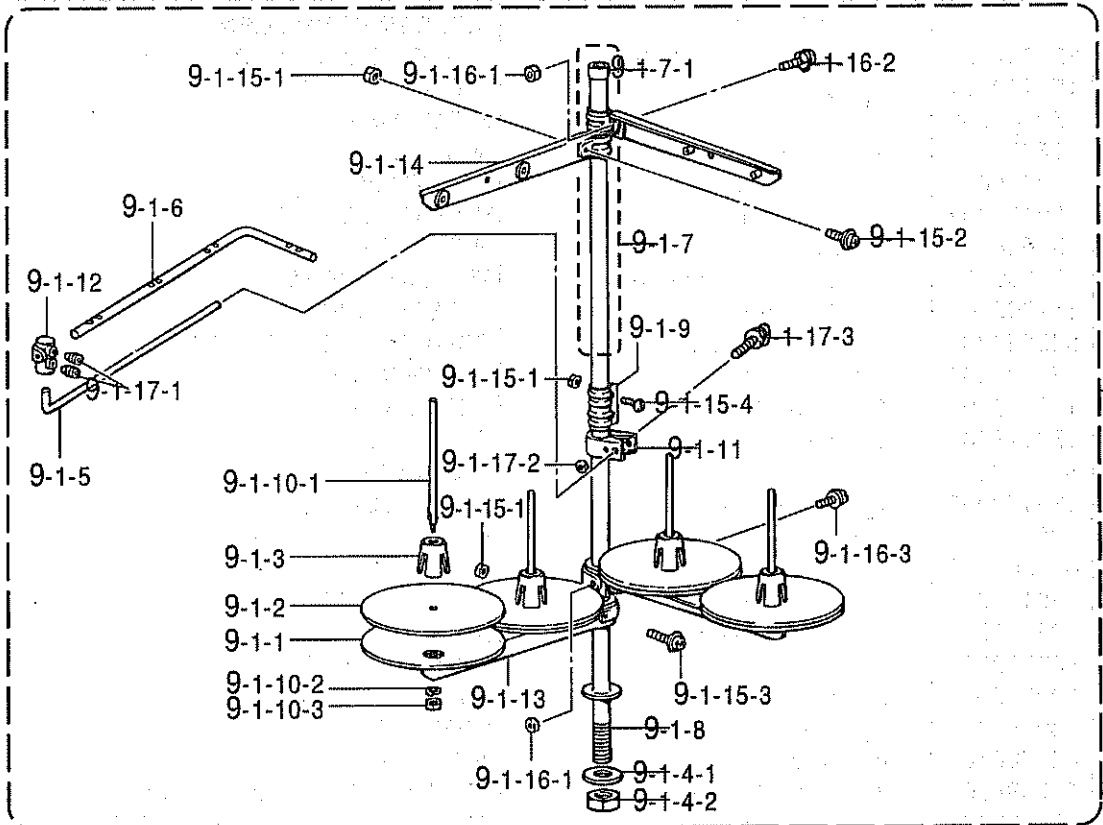

9-1

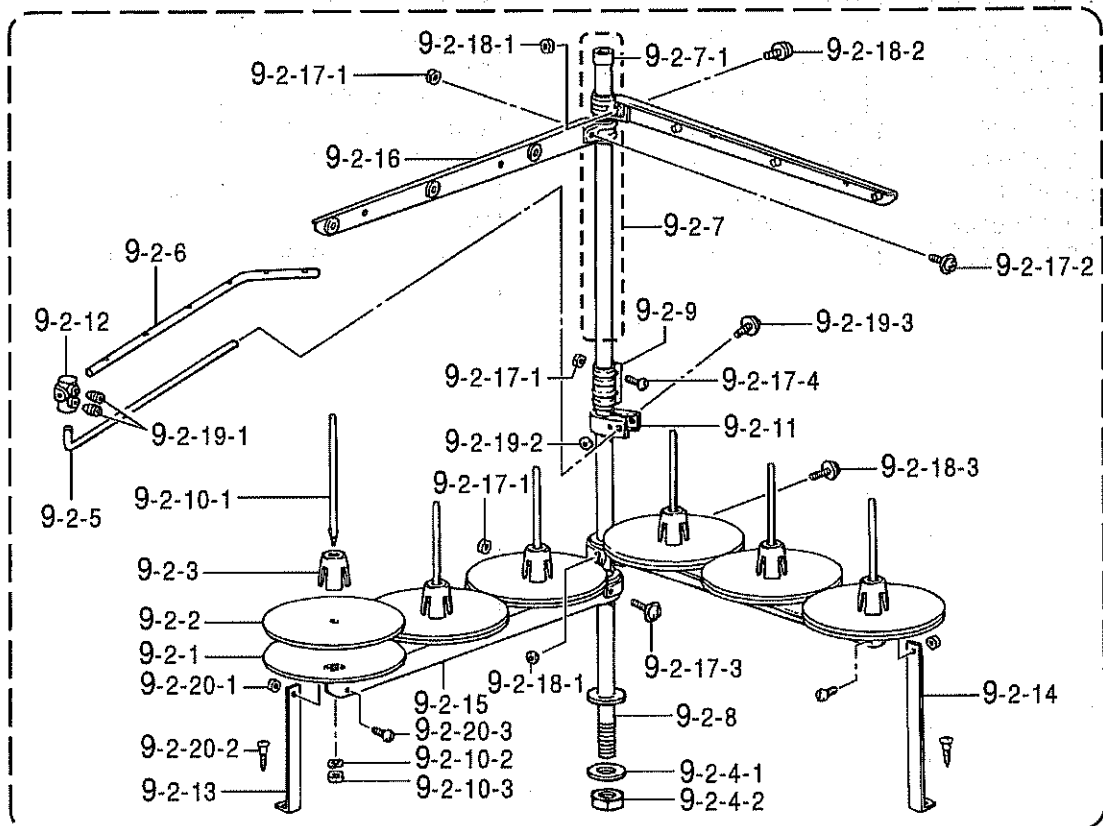











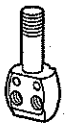
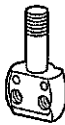
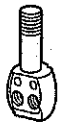

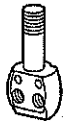
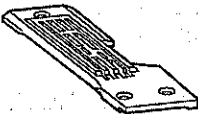
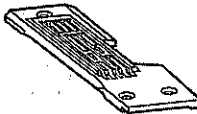
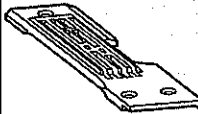
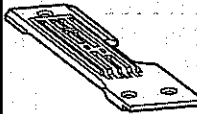
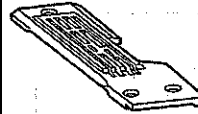
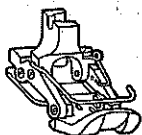
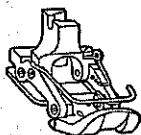
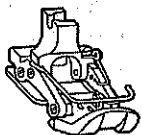
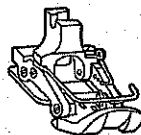
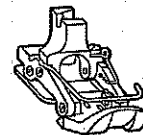
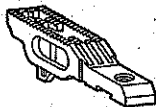
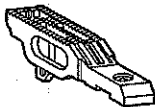
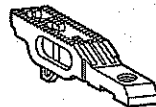
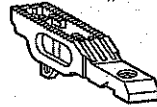
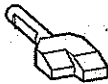
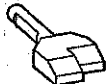
9-2

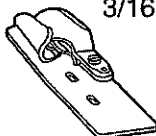
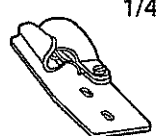
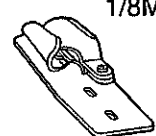
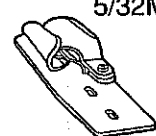
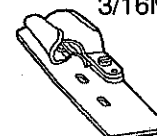
◎ 付属品の明細は変更することがあります。
 ◎ The details of included accessories are subject to change.

Z2. 付属品関係 / Accessories

REF.NO.	CODE	Q'TY	ヒンメイ	NAME OF PARTS	RM
			<三本針用>	<FOR THREE NEEDLE>	
9-2	S29864109	1	イトタテダイクミ6DTHF	COTTON STAND ASSY, 6DTHF	
9-2-1	150180001	6	ウケザラ	SPOOL STAND BASE	
9-2-2	150182000	6	スプールマット	SPOOL MAT	
9-2-3	126863001	6	スプールのクッション	SPOOL CUSHION	
9-2-4	S02775001	1	パイプネジセットA	PIPE SCREW SET, A	
9-2-4-1	150206002	1	ヒラザガネ16	WASHER, PLAIN 16	
9-2-4-2	S38648001	1	6カクナツトU5/8	NUT, U5/8-28	
9-2-5	S04109001	1	イトアンナイササエボウ	THREAD GUIDE SUPPORT BAR	
9-2-6	S02783001	1	イトアンナイ6	THREAD GUIDE, 6	
9-2-7	S40640001	1	コラムパイプキャップツキ	COLUMN PIPE WITH CAP	
9-2-7-1	150174000	1	コラムキャップ	COLUMN CAP	
9-2-8	156112003	1	コラムパイプD	COLUMN PIPE, D	
9-2-9	150173003	1	コラムジョイント	COLUMN JOINT	
9-2-10	S21798001	6	スプールのネジセット	SPOOL SCREW SET	
9-2-10-1	150179002	6	スプールのジクB	SPOOL SHAFT, B	
9-2-10-2	028050246	6	バネザガネ2-5	WASHER, SPRING 2-5	
9-2-10-3	021500106	6	1シユナツト5	NUT, 1 M5	
9-2-11	150185009	1	イトアンナイホルダー	THREAD GUIDE HOLDER	
9-2-12	138843001	1	ササエボウツギテ	JOINT	
9-2-13	150188009	1	スプールのホルダーササエA	SPOOL HOLDER SUPPORT, A	
9-2-14	150194009	1	スプールのホルダーササエB	SPOOL HOLDER SUPPORT, B	
9-2-15	S02779009	2	スプールのホルダー3	SPOOL HOLDER, 3	
9-2-16	S02788009	2	スレッドハンガークミ3	THREAD HANGER ASSY, 3	
9-2-17	S40641001	1	スプールのジクネジセットA	SPOOL SCREW SET, A	
9-2-17-1	021500106	4	1シユナツト5	NUT, 1 M5	
9-2-17-2	S37038001	1	ナベコヒラザ5X14	SCREW, PAN (P WASHER) M5X14	
9-2-17-3	S37037001	1	ナベコヒラザ5X32	SCREW, PAN (P WASHER) M5X32	
9-2-17-4	062501406	2	ナベコ5X14	SCREW, PAN M5X14	
9-2-18	S40642001	1	スプールのジクネジセットB	SPOOL SHAFT SCREW SET, B	
9-2-18-1	021500106	2	1シユナツト5	NUT, 1 M5	
9-2-18-2	S37038001	1	ナベコヒラザ5X14	SCREW, PAN (P WASHER) M5X14	
9-2-18-3	S37037001	1	ナベコヒラザ5X32	SCREW, PAN (P WASHER) M5X32	
9-2-19	S40643001	1	ホルダーツギテネジセット	HOLDER JOINT SCREW SET	
9-2-19-1	014060632	2	アナトメ6X6クボミ	SET SCREW, SOCKET (CP) M6X6	
9-2-19-2	021500106	1	1シユナツト5	NUT, 1 M5	
9-2-19-3	S37037001	1	ナベコヒラザ5X32	SCREW, PAN (P WASHER) M5X32	
9-2-20	S40644001	2	ホルダーツギテネジセット	HOLDER JOINT SCREW SET	
9-2-20-1	021500106	2	1シユナツト5	NUT, 1 M5	
9-2-20-2	031452206	2	マルモク45X22	WOOD SCREW, ROUND M4.5X22	
9-2-20-3	062501006	2	ナベコ5X10	SCREW, PAN M5X10	











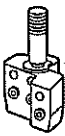

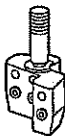
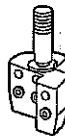

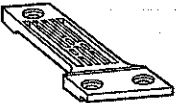
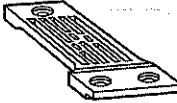
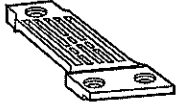
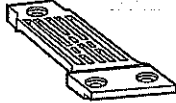
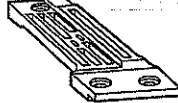
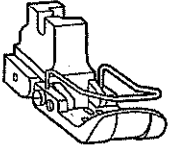
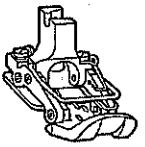
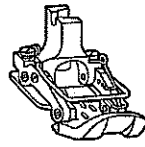
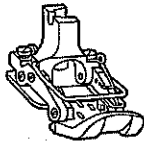
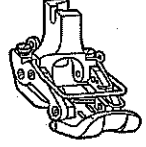
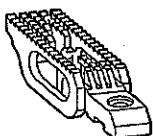
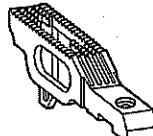
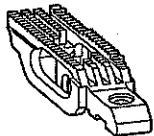
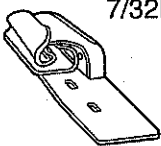
9270. 仕様別部品一覧表 / DIFFERENT PARTS LIST

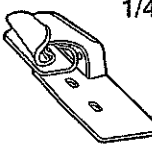
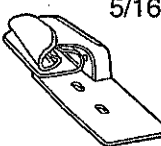
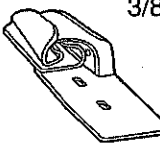
参照番号 Ref.No.	品名 Name of part	-1 薄物用 / -1 Thin materials		-2 中厚物用 / -2 Medium materials		
		4.8mm [3/16]	6.4mm [1/4]	3.2mm [1/8]	4.0mm [5/32]	4.8mm [3/16]
G-1	ハリダキネジツキ Needle clamp with screw	 183954-001	 183978-001	 183953-001	 183951-001	 183954-001
G-2	ハリ / Needle 針数 (本) No. of needles	TVX64NY#12 (2) S36861-012	←	TVX64NY#14 (2) S36861-014	←	←
G-3	ハリイタ Needle plate	 S05946-101	 S11508-101	 S40371-001	 S40373-001	 S05946-101
G-5	オサエクミ Presser foot assy	 S40355-001	 S40363-001	 S40367-001	 S40365-001	 S40355-001
G-7	オクリバ Feed dog	 S40369-001	 S40370-001	 S40372-001	←	 S40369-001
G-10	ハリウケ Needle guard	 S06310-001	 148973-001	 S06310-001	←	←
G-13	ラッパークミ Lapper assy	 101494-001	 S09679-001	 101488-001	 101949-001	 101497-001
G-20-1	ルーパ- Looper (S)	 S40391-001	 S40393-001	 S40389-001	←	 S40391-001
G-20-2	ルーパ- Looper (L)	 S40392-001	 S40394-001	 S40390-001	←	 S40392-001



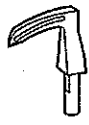





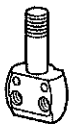
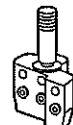
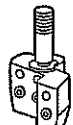
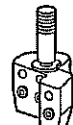

9270. 仕様別部品一覧表 / DIFFERENT PARTS LIST

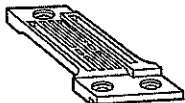
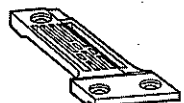
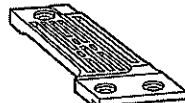
-2 中厚物用 / -2 Medium materials		-3 中厚物用 / -3 Medium materials		-A			参照番号 Ref.No.
4.8mm [3/16] 固定針受け / Fixed N.Guard		6.4mm [1/4] 固定針受け / Fixed N.Guard		薄物用 / Thin materials			
				4.8mm [3/16]	6.4mm [1/4]	3.2mm×2 [1/8×2]	
		←				G-1 ハリダキ ネジツキ Needle clamp with screw	
183954-001	183978-001		183954-001	183978-001	S16500-001		
TVX64NY#14 (2) S36861-014	TVX64NY#16 (2) S36861-016	←	TVX64NY#11PSU (2) S36861-031	←	TVX64NY#11PSU (3) S36861-031	G-2 ハリ / Needle 針数 (本) No. of needles	
		←				G-3 ハリイタ Needle plate	
S05946-101	S11508-101		S06318-101	S09672-101	S16475-101		
		←				G-5 オサエクミ Presser foot assy	
101491-101	106160-101		S06303-101	S09673-101	S16477-101		
						G-7 オクリバ Feed dog	
S05947-001	S40370-001	S11509-001	S06319-101	S09678-001	S16476-001		
						G-10 ハリウケ Needle guard	
105302-001	148973-001	106170-001	S06310-001	148973-001	S16482-001		
		←			←	G-13 ラッパークミ Lapper assy	
101497-001	101561-001		101494-001	S09679-001			
		←			(S) S40375-001	G-20-1 ルーバー-S Looper (S)	
S40391-001	S40393-001		S40391-001	S40393-001	(M) S40376-001		
		←			(L) S40377-001	G-20-2 ルーバー-L Looper (L)	
S40392-001	S40394-001		S40392-001	S40394-001	S40377-001		

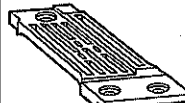
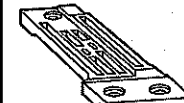
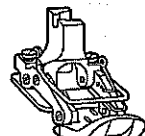
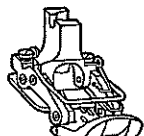
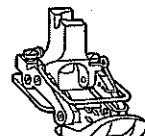
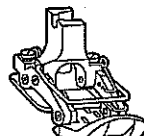
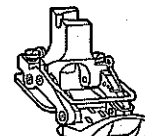
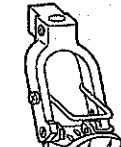
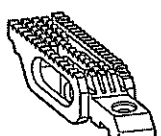
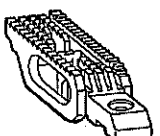
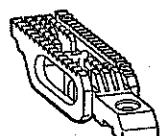
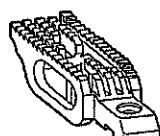
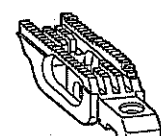
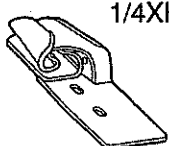
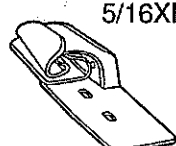
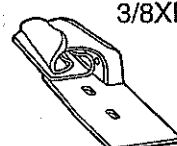
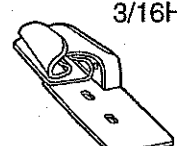
9280. 仕様別部品一覧表 / DIFFERENT PARTS LIST

参照番号 Ref.No.	-5 厚物用 / -5 Heavy materials					
	2.8mm×2 [7/64×2]	3.2mm×2 [1/8×2]	3.2mm×2 [1/8×2]	4.0mm×2 [5/32×2]	4.8mm×2 [3/16×2]	4.8mm [3/16]
G-1 ハリダキ ネジツキ Needle clamp with screw	 183952-001	 181716-001	←	 181723-001	 181722-001	 183954-001
G-2 ハリ / Needle 針数 (本) No. of needles	TVX5#130 (3) S43401-021	←	←	←	←	TVX5#130 (2) S43401-021
G-3 ハリイタ Needle plate	 S40790-001	 S13042-001	←	 S40787-001	 S40783-001	 159583-001
G-5 オサエクミ Presser foot assy	 S40788-001	 S40386-001	←	 S40785-001	 S40781-001	 159584-201
G-7 オクリバ Feed dog	 S13045-101	←	←	 S40784-001	←	 159588-001
G-14 ラッパーキ Lapper assy	 111171-101	 101561-001	 101564-001	 111177-001	 111183-001	 159609-001
G-18-1 ルーパー-S Looper (S)	 S40375-001	←	←	 S40395-001	←	 S40375-001
G-18-2 ルーパー-M Looper (M)	 S40376-001	←	←	←	←	
G-18-3 ルーパー-L Looper (L)	 S40377-001	←	←	 S40396-001	←	 S40377-001

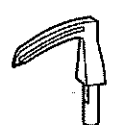
9280. 仕様別部品一覧表 / DIFFERENT PARTS LIST

-7					-C	参照番号 Ref.No.
デニム用 / Extra heavy materials					厚物 / Heavy materials	
6.4mm [1/4]	3.2mm×2 [1/8×2] 段差 1.0 / Height Difference 1.0	3.2mm×2 [1/8×2] 段差 1.9 / Height Difference 1.9	4.0mm×2 [5/32×2]	4.8mm×2 [3/16×2]	4.8mm [3/16]	
 183978-001	 181716-001	←	 181723-001	 181722-001	 183954-001	G-1 ハリダキ ネジツキ Needle clamp with screw
TVX5#140 (2) S43401-022	TVX5#140 (3) S43401-022	←	←	←	TVX5#140 (2) S43401-021	G-2 ハリ / Needle 針数 (本) No. of needles
 147867-001	 S18086-001	 148864-001	 148944-001	 148927-001	 159614-001	G-3 ハリイタ Needle plate
 147868-201	 S18081-201	 148865-201	 148945-201	 148928-201	 159615-101	G-5 オサエクミ Presser foot assy.
 148971-001	 S18084-101	 148867-101	 148932-101	←	 159616-001	G-7 オクリバ Feed dog
 147302-001	←	←	 148951-001	 148936-001	 159609-001	G-14 ラッパークミ Lapper assy
 S40375-001	←	←	 S40395-001	←	 S40375-001	G-18-1 ルーパー-S Looper (S)
/	 S40376-001	←	←	←	/	G-18-2 ルーパー-M Looper (M)
 S40377-001	←	←	 S40396-001	←	 S40377-001	G-18-3 ルーパー-L Looper (L)

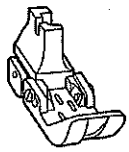

参照番号 Ref.No.	-C		-D			
	厚物 / Heavy materials	デニム / Extra heavy	デニム用 / Extra heavy materials			
	3.2mm×2 [1/8×2] 段差 0 / Height Difference 0	6.4mm [1/4]	3.2mm×2 [1/8×2] 段差 1.0 / Height Difference 1.0	3.2mm×2 [1/8×2] 段差 1.9 / Height Difference 1.9	4.0mm×2 [5/32×2]	4.8mm×2 [3/16×2]
G-1 ハリダキ ネジツキ Needle clamp with screw	 181716-001	 183978-001	←	←	 181723-001	 181722-001
G-2 ハリ / Needle 針数 (本) No. of needles	TVX5#130 (3) S43401-021	TVX5#140 (2) S43401-022	TVX5#140 (3) S43401-022	←	←	←
G-3 ハライタ Needle plate	 156175-001	 150666-001	 S01634-001	 150667-001	 151486-001	 151478-001
G-5 オサエクミ Presser foot assy	 156179-101	 150668-101	 S01632-101	 150672-101	 151487-101	 151479-101
G-7 オクリバ Feed dog	 156182-101	 150673-001	 S01635-101	 150675-101	 151483-101	←
G-14 ラッパークミ Lapper assy	 101564-001	 147302-001	 147302-001	←	 148951-001	 148936-001
G-18-1 ルーパーS Looper (S)	 S40375-001	←	←	←	 S40395-001	←
G-18-2 ルーパーM Looper (M)	 S40376-001	/		 S40376-001	←	←
G-18-3 ルーパーL Looper (L)	 S40377-001	←	←	←	 S40396-001	←

9280. オプション部品 / OPTION PARTS LIST

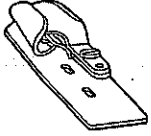
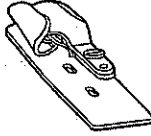
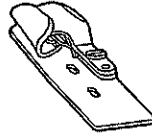
G-5 オサエクミ Presser foot assy	厚物 / Heavy materials 3.2mm×2 [1/8×2]
	 S13043-101

G-14 ラッパークミ Lapper assy	中厚物用 / Medium materials		
	7/32MH  111168-001	5/16MH  111174-001	3/8MH  111180-001

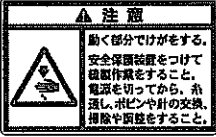
警告ラベル / Warning labels

警告ラベル / Warning labels	品名 / Name of parts	Size(mm)	Code
 <p>▲ 注意 動く部分でけがをする。 安全保護装置をつけて 修理作業をすること。 電源を切ってから、糸 通し、ボビンや針の交換、 掃除や調整をすること。</p>	<p>操作注意ラベル・和</p>	<p>40×64</p>	<p>S38350-001</p>
 <p>▲ CAUTION Moving parts may cause injury. Operate with safety devices. Turn off main switch before threading, changing bobbin and needles, cleaning etc.</p>	<p>Label, operation Eng.</p>	<p>40×64</p>	<p>S38349-001</p>
	<p>アースマーク Mark, grounding</p>	<p>ø12</p>	<p>S37060-001</p>

索引 / INDEX

CODE	REF.NO.	Page
SS4037700	G-20-2	56
SS4340102	G-2	58
S01295001	G3 -5-1-3	16
	G4 -5-3	18
	G5 -5-3	20
S01632101	G-5	59
S01634001	G-3	59
S01635101	G7 -7-2	24
	G-7	59
S01637001	G5 -7-2-1	20
	G7 -7-2-1	24
S01943001	Z1 -2-3	50
S02775001	Z2 -9-1-4	52
	Z2 -9-2-4	54
S02778002	Z2 -9-1-13	52
S02779009	Z2 -9-2-15	54
S02783001	Z2 -9-2-6	54
S02786002	Z2 -9-1-14	52
S02788009	Z2 -9-2-16	54
S04109001	Z2 -9-1-5	52
	Z2 -9-2-5	54
S05946101	G-3	55
	G-3	55
	G-3	56
S05947001	G-7	56
S06259001	D1 -1-1	4
	D2 -1-1	6
S06260001	D2 -1-3	6
S06261001	D1 -1-2	4
	D2 -1-2	6
S06303101	G2 -5-1	14
	G-5	56
S06309001	G2 -5-1-2	14
	G2 -5-2-2	14
S06310001	G-10	55
	G-10	55
	G-10	56
S06311201	H -5-22-1	28
S06314001	G1 -22-2	12
	G2 -22-2	14
S06315001	G1 -22-1	12
	G2 -22-1	14
S06318101	G-3	56
S06319101	G-7	56
S06704001	Z1 -29	50
S08758009	Z1 -24	50
S08761100	Z1 -26	50
S08969101	Z1 -27	50
S08987001	M1 -22-1	44
	M1 -22-2	44
	M1 -54	44
	M2 -22-1	48
	M2 -22-2	48
S09180101	G2 -5-1-5	14
	G2 -5-2-4	14
S09397001	G3 -5-2-1	16
S09672101	G-3	56
S09673101	G-5	56
S09678001	G-7	56
S09679001	G1 -13-3	12
	G2 -13-2	14
	G-13	55
	G-13	56

CODE	REF.NO.	Page
S11508101	G-3	55
	G-3	56
S11509001	G-7	56
S13042001	G-3	57
S13043101	G-5	60
S13045101	G-7	57
S16475101	G-3	56
S16476001	G-7	56
S16477101	G-5	56
S16482001	G-10	56
S16487151	M1 -47-2	44
S16488001	H -10	28
S16490101	K -16-2	32
S16500001	G-1	56
S18018201	G-5	58
S18084101	G5 -7-2	20
	G-7	58
S18086001	G-3	58
S18874001	C -7	4
S21798001	Z2 -9-1-10	52
	Z2 -9-2-10	54
S25125001	H -1-7	26
S25126001	H -1-20	26
S29854109	Z2 -9-1	52
S29864109	Z2 -9-2	54
S30564000	L1 -7-1-1-8	34
	L1 -7-2-1-8	34
	L2 -7-1-1-8	38
	L2 -7-2-1-8	40
S30565002	L1 -7-1-1-9	34
	L1 -7-2-1-9	34
	L2 -7-1-1-9	38
	L2 -7-2-1-9	40
S30565003	L1 -7-1-1-10	34
	L1 -7-2-1-10	36
	L2 -7-1-1-10	38
	L2 -7-2-1-10	40
S30565004	L1 -7-2-1-11	36
	L2 -7-2-1-11	40
S36058001	H -1-15	26
S36061001	H -1-24	26
S36861012	G-2	55
S36861014	G-2	55
	G-2	56
S36861016	G-2	56
S36861031	G-2	56
	G-2	56
S36862001	K -29	32
S37037001	Z2 -9-1-15-3	52
	Z2 -9-1-16-3	52
	Z2 -9-1-17-3	52
	Z2 -9-2-17-3	54
	Z2 -9-2-18-3	54
	Z2 -9-2-19-3	54
S37038001	Z2 -9-1-15-2	52
	Z2 -9-1-16-2	52
	Z2 -9-2-17-2	54
	Z2 -9-2-18-2	54
S37060001		61
S37186001	L1 -23	34
	L2 -34	38
S38309001	F -1-1-3	10
	F -1-2-3	10

CODE	REF.NO.	Page
S38309001	F -1-3-3	10
S38349001		61
S38350001		61
S38648001	Z2 -9-1-4-2	52
	Z2 -9-2-4-2	54
S39585001	F -1-1-4	10
	F -1-2-4	10
	F -1-3-4	10
S39586001	F -1-1-5	10
	F -1-2-5	10
	F -1-3-5	10
S40258001	E -8	8
S40259001	E -10	8
S40261001	E -17	8
S40262001	E -18	8
S40264001	E -25	8
S40265001	E -3-1	8
S40266051	M1 -32	42
	M2 -32	46
S40268001	C -1	4
S40271051	C -9-1	4
S40272051	C -9-2	4
S40273051	C -9-3	4
S40274001	F -1-1	10
S40274002	F -1-2	10
S40279001	D1 -16	4
	D2 -22	6
S40280001	E -1-1	8
S40281001	E -1-2	8
S40282000	F -3	10
S40285001	F -5	10
S40288000	F -6	10
S40289051	F -7	10
S40290051	F -12	10
S40291001	F -1-3	10
S40298051	D1 -6	4
S40299001	D1 -2	4
S40300001	D1 -13	4
	D2 -19	6
S40301001	D1 -14	4
	D2 -20	6
S40302000	K -2	32
S40303001	K -7	32
S40306001	K -20	32
S40307001	K -21	32
S40308001	K -24	32
S40310001	L1 -12	34
	L2 -12	38
S40312001	L1 -12-1	34
	L2 -12-1	38
S40313051	L1 -13	34
	L2 -13	38
S40314001	B -1	2
S40315051	B -5	2
S40316051	B -6	2
	J -8	30
S40317001	B -9	2
S40318051	B -8	2
S40319001	M1 -10	42
	M2 -10	46
S40320051	M1 -11	42
	M2 -11	46
S40321051	M1 -13	42

CODE	REF.NO.	Page
S40321051	M2 - 13	46
S40322051	M1 - 15	42
	M2 - 15	46
S40323001	M1 - 21	42
	M2 - 21	46
S40324001	M1 - 25-1	44
	M1 - 25-2	44
	M1 - 57	44
	M2 - 25-1	48
	M2 - 25-2	48
S40325001	M1 - 28	42
	M2 - 28	46
S40326051	M1 - 32-6	42
	M2 - 32-6	46
S40327051	M1 - 32-10	42
	M2 - 32-10	46
S40328051	M1 - 32-14	42
	M2 - 32-14	46
S40329051	M1 - 32-16	42
	M2 - 32-16	46
S40330051	M1 - 35	42
S40335051	M1 - 42	42
	M2 - 42	46
S40336051	M2 - 42-1	48
S40337051	M2 - 42-2	48
S40338051	M1 - 43	42
	M2 - 43	46
S40339051	M2 - 43-1	48
S40340051	M2 - 43-2	48
S40341001	M1 - 49	44
S40342051	M2 - 35	46
S40355001	G-5	55
	G-5	55
S40358001	G1 - 5-3-2	12
S40360001	G1 - 5-3-4	12
S40363001	G-5	55
S40365001	G-5	55
S40367001	G-5	55
S40369001	G-7	55
	G-7	55
S40370001	G-7	55
	G-7	56
S40371001	G-3	55
S40372001	G-7	55
S40373001	G-3	55
S40374001	G1 - 5-3-6	12
S40375001	G2 - 20-3	14
	G4 - 18-1	18
	G5 - 18-1	20
	G6 - 18-1	22
	G-18-1	57
	G-18-1	57
	G-18-1	58
	G-18-1	58
	G-18-1	59
	G-20-1	56
S40376001	G2 - 20-4	14
	G5 - 18-2	20
	G-18-2	57
	G-18-2	58
	G-18-2	59
	G-20-1	56
S40377001	G2 - 20-5	14

CODE	REF.NO.	Page
S40377001	G4 - 18-3	18
	G5 - 18-3	20
	G6 - 18-3	22
	G-18-3	57
	G-18-3	57
	G-18-3	58
	G-18-3	58
	G-18-3	59
S40378051	G2 - 22-3	14
	G3 - 20-1	16
	G4 - 20-1	18
	G5 - 20-1	20
	G6 - 20-1	22
	G7 - 20-1	24
S40379051	G2 - 22-4	14
	G3 - 20-2	16
	G5 - 20-2	20
	G7 - 20-2	24
S40380051	G2 - 22-5	14
	G3 - 20-3	16
	G4 - 20-3	18
	G5 - 20-3	20
	G6 - 20-3	22
	G7 - 20-3	24
S40383001	B - 10-1	2
S40386001	G-5	57
S40389001	G-20-1	55
S40390001	G-20-2	55
S40391001	G-20-1	55
	G-20-1	55
	G-20-1	56
	G-20-1	56
S40392001	G-20-2	55
	G-20-2	55
	G-20-2	56
	G-20-2	56
S40393001	G-20-1	55
	G-20-1	56
	G-20-1	56
S40394001	G-20-2	55
	G-20-2	56
	G-20-2	56
S40395001	G-18-1	57
	G-18-1	58
	G-18-1	59
S40396001	G-18-3	57
	G-18-3	58
	G-18-3	59
S40399001	G1 - 11	12
	G2 - 11	14
	G3 - 11	16
	G4 - 11	18
	G5 - 11	20
	G6 - 11	22
	G7 - 11	24
S40640001	Z2 - 9-1-7	52
	Z2 - 9-2-7	54
S40641001	Z2 - 9-1-15	52
	Z2 - 9-2-17	54
S40642001	Z2 - 9-1-16	52
	Z2 - 9-2-18	54
S40643001	Z2 - 9-1-17	52
	Z2 - 9-2-19	54

CODE	REF.NO.	Page
S40644001	Z2 - 9-2-20	54
S40781001	G-5	57
S40783001	G-3	57
S40784001	G-7	57
S40785001	G-5	57
S40787001	G-3	57
S40788001	G3 - 5-2	16
	G-5	57
	G-3	57
S40790001	K - 7-3	32
S40792001	K - 8	32
S40795101	M1 - 32-12	42
	M2 - 32-12	46
S40796001	E - 14	8
S40797000	E - 21	8
S40798050	D1 - 4	4
	D2 - 4	6
S40799051	M1 - 45	42
	M2 - 45	48
S40800001	F - 13	10
S40804001	G3 - 5-1-7	16
S40812001	B - 10	2
S40818001	E - 5	8
S40819000	E - 7	8
S41311051	F - 9	10
S41312001	E - 3-2	8
S41314000	H - 5-3	26
S41315001	H - 5-22-2	28
S41316009	L2 - 7-1	38
S41318009	L2 - 7-2	40
S43401021	G3 - 2	16
	G-2	57
	G-2	57
	G-2	58
	G-2	59
S43401022	G-2	58
	G-2	59
	G-2	59
S43446009	L1 - 7-1	34
S43448009	L1 - 7-2	34
0B0622502	A - 4	2
0B1512502	Z1 - 17	50
012060632	F - 2	10
013760610	L2 - 22	38
	M1 - 38	42
	M2 - 38	46
014060632	Z2 - 9-1-17-1	52
	Z2 - 9-2-19-1	54
014680422	H - 1-27	26
	H - 5-15	28
	H - 5-20	28
	H - 5-23	28
	M1 - 35-1	42
	M2 - 35-1	46
014680622	H - 5-23	28
014760622	E - 23	8
	F - 8	10
	H - 1-5	26
	H - 1-10	26
	H - 1-16	26
	H - 1-17	26
	H - 1-23	26
	H - 1-25	26

CODE	REF.NO.	Page
014760622	H - 11	28
	H - 11	28
	D1 - 5	4
	D2 - 5	6
	G2 - 6	14
	G6 - 6	22
	G7 - 6	24
014761030	F - 11	10
	K - 14	32
014770622	E - 4	8
	E - 6	8
	F - 4-1-1	10
	F - 4-2-1	10
	H - 5-12	28
014771022	C - 10	4
014781032	E - 2	8
017821813	H - 3	26
017822212	H - 2	26
021400106	Z1 - 21	50
021500106	Z2 - 9-1-10-3	52
	Z2 - 9-1-15-1	52
	Z2 - 9-1-16-1	52
	Z2 - 9-1-17-2	52
	Z2 - 9-2-10-3	54
	Z2 - 9-2-17-1	54
	Z2 - 9-2-18-1	54
	Z2 - 9-2-19-2	54
	Z2 - 9-2-20-1	54
021670102	G1 - 18	12
	G2 - 18	14
	G3 - 16	16
	G4 - 16	18
	G5 - 16	20
	G6 - 16	22
	G7 - 16	24
021680202	M1 - 23-1	44
	M1 - 23-2	44
	M2 - 23-1	48
	M2 - 23-2	48
021710212	D2 - 11	6
025060232	H - 5-29	28
025080132	H - 4	26
025710132	F - 15	10
026030136	M1 - 32-21	42
	M2 - 32-21	46
028050246	Z2 - 9-1-10-2	52
	Z2 - 9-2-10-2	54
031452206	Z2 - 9-2-20-2	54
047200842	M1 - 44	42
047201640	H - 1-1-1	26
047301242	F - 1-1-1-1	10
	F - 1-1-2-1	10
	F - 1-2-1-1	10
	F - 1-2-2-1	10
	F - 1-3-1-1	10
	F - 1-3-2-1	10
047501242	M1 - 33	42
	M2 - 33	46
048040342	F - 16	10
	H - 1-44	26
048420242	B - 4	2
	J - 7	30
060660416	M1 - 32-11	42

CODE	REF.NO.	Page
060660416	M1 - 32-13	42
	M2 - 32-11	46
	M2 - 32-13	46
060660512	G2 - 5-1-6	14
	G2 - 5-2-5	14
	G6 - 5-5	22
	G7 - 5-1-5	24
	G7 - 5-2-5	24
	G7 - 5-3-6	24
060670512	M1 - 12	42
	M2 - 12	46
060670612	L2 - 19	38
060670812	G1 - 6	12
	G3 - 6	16
	G4 - 6	18
	G5 - 6	20
	L1 - 16	34
060680712	Z1 - 28	50
062401406	Z1 - 22	50
062501006	Z2 - 9-2-20-3	54
062501406	Z2 - 9-1-15-4	52
	Z2 - 9-2-17-4	54
062630412	L1 - 3	34
	L1 - 18	36
	L2 - 3	38
	L2 - 16	40
	M1 - 50	44
	M1 - 52	44
	M2 - 52	48
062630612	G2 - 5-1-4	14
062660412	M1 - 32-15	42
	M1 - 32-17	42
	M2 - 32-15	46
	M2 - 32-17	46
062660512	G3 - 5-1-10	16
	G4 - 5-10	18
	G5 - 5-10	20
	L1 - 12-2	34
	L2 - 12-2	38
062660612	M1 - 48-1	44
062670412	G1 - 13-1-1	12
	M1 - 5	42
	M2 - 5	46
062670512	K - 25	32
	L1 - 5	34
	L2 - 5	38
	M1 - 6	42
	M2 - 6	46
062670612	C - 5	4
	M1 - 14	42
	M1 - 16	42
	M1 - 27	42
	M1 - 29	42
	M1 - 32-7	42
	M1 - 41	42
	M2 - 14	46
	M2 - 16	46
	M2 - 27	46
	M2 - 29	46
	M2 - 32-7	46
	M2 - 41	46
062670712	H - 1-8	26
	H - 1-21	26

CODE	REF.NO.	Page
062670712	L1 - 14	34
	L2 - 14	38
	M1 - 46	44
062670812	M1 - 9	42
	M2 - 9	46
062671012	H - 1-39	26
	G1 - 19	12
	G2 - 19	14
	G2 - 23-2	14
	G3 - 17	16
	G3 - 21	16
	G4 - 17	18
	G4 - 21	18
	G5 - 17	20
	G5 - 21	20
	G6 - 17	22
	G6 - 21	22
	G7 - 17	24
	G7 - 21	24
	M1 - 7	42
	M1 - 20	42
	M2 - 7	46
	M2 - 20	46
062671412	M1 - 48-2	44
	M2 - 48	48
062680512	H - 1-29	26
	D1 - 17	4
	D2 - 23	6
062680612	G1 - 21	12
	G2 - 21-1	14
062680712	E - 19	8
	H - 5-8-1	26
062680812	E - 26	8
	K - 19-1	32
062681012	H - 5-1	26
	D1 - 15	4
	D2 - 21	6
	G1 - 23	12
	G2 - 23-1	14
062710812	E - 13	8
	L1 - 24	34
	L2 - 35	38
062711012	B - 7	2
	J - 9	30
062711612	E - 9	8
062712012	L1 - 6	34
	L2 - 6	38
062761012	H - 5-30	28
071063550	D2 - 27	6
072600040	H - 1-2	26
072620070	J - 2	30
072620180	J - 3	30
072630260	B - 3	2
	J - 6	30
076302850	B - 2	2
081003670	H - 1-42	26
	K - 13	32
081005070	F - 14	10
081006070	F - 10	10
081007070	K - 27	32
081010870	K - 10	32
081014670	B - 10-3	2
081025570	H - 1-18	26

CODE	REF.NO.	Page
100022004	K -15-2	32
100032004	G1 -4	12
	G2 -4	14
	G3 -4	16
	G4 -4	18
	G5 -4	20
	G6 -4	22
	G7 -4	24
100058003	L2 -33-1	38
100064005	L1 -12-6	34
	L2 -12-6	38
	L2 -21-2	38
	M1 -34	42
	M2 -34	46
100251001	C -11-1	4
	C -11-1	4
	C -11-2	4
100257010	B -10-5	2
100260001	K -11	32
100279109	H -5-4	26
100366001	K -12-1	32
100463001	Z1 -14	50
100645003	L2 -31	38
100887001	Z1 -3-2	50
101488001	G-13	55
101491101	G1 -5-1	12
	G-5	56
101494001	G2 -13-1	14
	G-13	55
	G-13	56
101497001	G-13	55
	G-13	56
101561001	G-13	56
	G-14	57
101564001	G-14	57
	G-14	59
101572101	Z1 -2-2	50
101949001	G-13	55
102630001	C -3	4
102716004	J -5	30
102921002	D1 -10	4
	D2 -16	6
103408002	G1 -1-1	12
	G2 -1-1-1	14
	G4 -1-1	18
	G6 -1-1	22
104449009	A -13	2
104547001	B -10-2	2
105071001	B -10-7	2
105073001	L2 -27	38
105091001	D2 -2	6
105094009	D2 -6	6
105095001	D2 -7	6
105096009	D2 -8	6
105100001	D2 -9	6
105103001	D1 -7	4
	D2 -13	6
105104001	D1 -8	4
	D2 -14	6
105105009	D1 -9	4
	D2 -15	6
105106001	D1 -11	4
	D2 -17	6

CODE	REF.NO.	Page
105113001	H -1-45	26
105118000	G1 -5-1-1	12
	G1 -5-2-1	12
105129001	G1 -12	12
	G2 -12	14
	G3 -12	16
	G4 -12	18
	G5 -12	20
	G6 -12	22
	G7 -12	24
105130001	G1 -13-2-1	12
	G1 -14	12
	G2 -13-1-1	14
	G2 -14	14
	G3 -13	16
	G3 -14-1-1	16
	G4 -13	18
	G5 -13	20
	G6 -13	22
	G7 -13	24
105141001	E -12	8
105144001	E -15	8
105146001	A -3	2
105147101	J -1	30
105150000	J -4	30
105155001	J -10	30
105156002	J -11	30
105173004	G1 -8	12
	G2 -8	14
	G3 -8	16
	G4 -8	18
	G5 -8	20
	G6 -8	22
	G7 -8	24
105176001	K -3-1	32
	K -15-1-1	32
105177001	K -4	32
105178100	K -5	32
105179001	K -6	32
105183001	K -7-1	32
105184000	K -7-2	32
105191001	K -9	32
105193101	K -15	32
105198000	K -15-3	32
105200101	K -16-1	32
105201000	K -17	32
105215001	H -1-46	26
105216001	K -22	32
105217059	K -23	32
105221001	L1 -2-1	34
	L1 -2-2	34
	L2 -2-1	38
	L2 -2-2	40
	M1 -2-1	44
	M1 -2-2	44
105222001	L1 -4	34
	L2 -4	38
105231000	L1 -7-1-2	34
	L1 -7-2-2	36
	L2 -7-1-2	38
	L2 -7-2-2	40
105233002	L1 -7-1-4	34
	L1 -7-2-4	36

CODE	REF.NO.	Page
105233002	L2 -7-1-4	40
	L2 -7-2-4	40
105234003	L1 -7-1-5	34
	L1 -7-2-5	36
	L2 -7-1-5	40
	L2 -7-2-5	40
	L2 -32	38
105235251	L1 -8	34
	L2 -8	38
105236001	L1 -10	34
	L2 -10	38
105237002	L1 -11	34
	L2 -11	38
105243001	L1 -12-3	34
	L2 -12-3	38
105244000	L1 -12-4	34
	L2 -12-4	38
105245001	L1 -12-5	34
	L2 -12-5	38
105251009	M1 -8-1	44
	M2 -8-1	48
105257009	M1 -18	42
	M2 -18	46
105260009	M1 -19	42
	M2 -19	46
105277001	L2 -30	38
105280009	M1 -32-1	42
	M2 -32-1	46
105281001	M1 -32-2	42
	M2 -32-2	46
105284101	M1 -32-4	42
	M2 -32-4	46
105285000	M1 -32-5	42
	M2 -32-5	46
105287001	M1 -32-8	42
	M2 -32-8	46
105288001	M1 -32-9	42
	M1 -32-20	42
	M2 -32-9	46
	M2 -32-20	46
105296001	M1 -32-18	42
	M2 -32-18	46
105300101	M1 -36	42
	M2 -36	46
105301001	M1 -37-1	44
105302001	G-10	56
105303001	G1 -9-1	12
105304001	M1 -47-1	44
105333001	D1 -12	4
	D2 -18	6
105337001	A -2	2
105341051	A -5	2
105344001	Z1 -2-1	50
105359001	Z1 -18	50
106062009	Z1 -15	50
106160101	G1 -5-2	12
	G-5	56
106170001	G-10	56
106568003	H -5-17	28
106794001	H -5-6	26
107153001	C -2	4
108960002	M1 -31	42
	M2 -31	46

CODE	REF.NO.	Page
109153001	H -1-26	26
109656009	Z1 -13	50
109657009	Z1 -16	50
109993001	C -16	4
110813001	L1 -7-1-1-3	34
	L1 -7-2-1-3	34
	L2 -7-1-1-3	38
	L2 -7-2-1-3	40
110832009	L1 -7-1-1-4	34
	L1 -7-2-1-4	34
	L2 -7-1-1-4	38
	L2 -7-2-1-4	40
111024101	C -8	4
111025001	D1 -3-1	4
	D2 -3-1	6
111070109	L1 -1	34
	L2 -1	38
111072009	L1 -17	36
	L2 -15	40
	M1 -51	44
	M2 -51	48
111073001	L1 -19	36
	L2 -17	40
	M1 -3	42
	M1 -53	44
	M2 -3	46
	M2 -53	48
111075059	L1 -7-1-1-1	34
	L1 -7-2-1-1	34
	L2 -7-1-1-1	38
	L2 -7-2-1-1	40
111076151	L1 -7-1-3	34
	L1 -7-2-3	36
	L2 -7-1-3	40
	L2 -7-2-3	40
111077001	L1 -15	34
	L2 -18	38
111078051	L2 -20	38
111079001	L2 -21-1	38
111082051	L2 -21-5	38
111083001	L1 -20	34
	L2 -23	38
111084001	L1 -22	34
	L2 -25	38
111089001	L2 -26	38
111093001	L2 -29	38
111095009	M1 -1	42
	M2 -1	46
111096009	M1 -4	42
	M2 -4	46
111097009	M1 -8-2	44
	M2 -8-2	48
111105002	G1 -5-3-3	12
	G3 -5-1-12	16
	G4 -5-12	18
	G5 -5-12	20
111112001	M1 -32-19	42
	M2 -32-19	46
111113101	M1 -39	42
	M2 -39	46
111114101	M1 -40	42
	M2 -40	46
111128022	G5 -2	20

CODE	REF.NO.	Page
111140001	G1 -5-2-2	12
111168001	G-14	60
111171001	G-14	57
111174001	G-14	60
111177001	G-14	57
111180001	G-14	60
111183001	G-14	57
111188001	L1 -21	34
	L2 -24	38
111189001	L2 -28	38
111193001	B -10-6	2
111194001	B -10-8	2
111443003	G1 -9-2	12
	G2 -9	14
	G2 -21-2	14
	G2 -21-2	14
	G3 -10	16
	G3 -19	16
	G4 -10	18
	G4 -19	18
	G5 -10	20
	G5 -19	20
	G6 -10	22
	G7 -10	24
	G7 -19	24
111506101	L2 -21	38
111863001	C -13	4
112618001	H -5-9	26
112658001	M1 -30	42
	M2 -30	46
113605051	C -6	4
114483002	Z1 -6	50
115132002	L2 -21-4	38
116016001	Z1 -20	50
116577051	E -11	8
117437109	Z1 -12	50
117466000	Z1 -5	50
117934009	H -1-12	26
	D1 -19	4
	D2 -25	6
122771001	G3 -14-2-1	16
	G4 -14-1-1	18
	G5 -14-1	20
	G6 -14-1-1	22
	G7 -14-1	24
122771002	M1 -32-3	42
	M2 -32-3	46
122991001	Z1 -1	50
123006001	C -12	4
126863001	Z2 -9-1-3	52
	Z2 -9-2-3	54
133636009	Z1 -10	50
138843001	Z2 -9-1-12	52
	Z2 -9-2-12	54
140004001	C -1-2	4
140518001	K -26	32
140890009	C -14	4
141099001	H -5-7	26
142274009	C -1-1	4
	M1 -17	42
	M2 -17	46
142627001	E -16	8
142721001	Z1 -3-1	50

CODE	REF.NO.	Page
142747002	G7 -5-3-2	24
142998101	Z2 -9-1-6	52
144103009	L1 -7-1-1-6	34
	L1 -7-2-1-6	34
	L2 -7-1-1-6	38
	L2 -7-2-1-6	40
144104001	L1 -7-1-1-7	34
	L1 -7-2-1-7	34
144228001	Z1 -8	50
144504001	M1 -24-1	44
	M1 -24-2	44
	M1 -56	44
	M2 -24-1	48
	M2 -24-2	48
145440001	L1 -7-1-1-2	34
	L1 -7-2-1-2	34
	L2 -7-1-1-2	38
	L2 -7-2-1-2	40
145446001	L1 -7-1-1-5	34
	L1 -7-2-1-5	34
	L2 -7-1-1-5	38
	L2 -7-2-1-5	40
145688000	C -4	4
146354001	M1 -55	44
146427001	G2 -1-2-1	14
	G3 -1-1	16
	G5 -1-1	20
	G7 -1-1	24
147291001	M1 -37-2	44
	M2 -37	46
147302001	G4 -14-1	18
	G6 -14-1	22
	G-14	58
	G-14	59
	G-14	59
147307001	G4 -7-1-1	18
	G5 -7-1-1	20
	G6 -7-1-1	22
	G7 -7-1-1	24
147865001	D2 -3-2	6
147867001	G-3	58
147868201	G-5	58
147871001	G1 -5-3-1	12
	G2 -5-1-1	14
	G2 -5-2-1	14
	G3 -5-1-1	16
	G4 -5-1	18
	G5 -5-1	20
147872001	G3 -5-1-2	16
	G4 -5-2	18
	G5 -5-2	20
147875001	G3 -5-1-6	16
	G4 -5-6	18
	G5 -5-6	20
147876001	G3 -5-1-7	16
	G4 -5-7	18
	G5 -5-7	20
147877001	G3 -5-1-8	16
	G4 -5-8	18
	G5 -5-8	20
147878001	G3 -5-1-9	16
	G4 -5-9	18
	G5 -5-9	20

CODE	REF.NO.	Page
147879001	G4 - 5-11	18
	G5 - 5-11	20
147880001	G4 - 7-1-2	18
	G4 - 7-2-2	18
	G5 - 7-1-2	20
	G5 - 7-2-2	20
	G6 - 7-1-2	22
	G6 - 7-2-2	22
	G7 - 7-1-2	24
	G7 - 7-2-2	24
147890001	G3 - 5-1-4	16
	G4 - 5-4	18
	G5 - 5-4	20
147932001	G1 - 5-3-5	12
	G2 - 5-1-3	14
	G2 - 5-2-3	14
	G3 - 5-1-5	16
	G4 - 5-5	18
	G5 - 5-5	20
	G6 - 5-3	22
	G7 - 5-1-3	24
	G7 - 5-2-3	24
	G7 - 5-3-4	24
148006001	D2 - 10	6
148007051	D2 - 12	6
148294001	H - 1-33	26
148298001	Z1 - 23	50
148851001	L2 - 7-1-1-7	38
	L2 - 7-2-1-7	40
148864001	G-3	58
148865201	G-5	58
148867101	G-7	58
148875001	G3 - 9	16
	G5 - 9	20
	G7 - 9	24
148876001	G1 - 17	12
	G2 - 17	14
	G3 - 15	16
	G4 - 15	18
	G5 - 15	20
	G6 - 15	22
	G7 - 15	24
148877100	K - 18	32
148927001	G-3	58
148928201	G-5	58
148932101	G-7	58
148936001	G-14	58
	G-14	59
148944001	G-3	58
148945201	G-5	58
148951001	G-14	58
	G-14	59
148971001	G4 - 7-1	18
	G-7	58
148973001	G4 - 9	18
	G6 - 9	22
	G-10	55
	G-10	56
	G-10	56
149011051	L2 - 21-3	38
150173003	Z2 - 9-1-9	52
	Z2 - 9-2-9	54
150174000	Z2 - 9-1-7-1	52

CODE	REF.NO.	Page
150174000	Z2 - 9-2-7-1	54
150179002	Z2 - 9-1-10-1	52
150179002	Z2 - 9-2-10-1	54
150180001	Z2 - 9-1-1	52
	Z2 - 9-2-1	54
150182000	Z2 - 9-1-2	52
	Z2 - 9-2-2	54
150185009	Z2 - 9-1-11	52
	Z2 - 9-2-11	54
150188009	Z2 - 9-2-13	54
150194009	Z2 - 9-2-14	54
150206002	Z2 - 9-1-4-1	52
	Z2 - 9-2-4-1	54
150608001	H - 1-22	26
150611001	H - 1-28	26
150612001	H - 1-30	26
150613001	H - 1-31	26
150614001	H - 1-32	26
150641001	H - 1-40	26
150659001	E - 22	8
150661001	E - 24	8
150665001	D1 - 3-2	4
	D2 - 3-3	6
150666001	G-3	59
150667001	G-3	59
150668101	G-5	59
150670001	G6 - 5-1	22
	G7 - 5-1-1	24
	G7 - 5-3-1	24
150671001	G6 - 5-2	22
	G7 - 5-1-2	24
	G7 - 5-3-3	24
150672101	G7 - 5-1	24
	G-5	59
150673001	G6 - 7-1	22
	G-7	59
150675101	G-7	59
150679001	H - 1-1	26
150682000	H - 1-3	26
150683000	H - 1-4	26
150684001	H - 1-6	26
150686101	H - 1-9	26
150687000	H - 1-11	26
150688101	H - 1-13	26
150690101	H - 1-14	26
150693000	H - 1-19	26
150695000	H - 1-34	26
150696001	H - 1-35	26
150697001	A - 12	2
	H - 1-36	26
150698009	H - 1-37	26
150699000	H - 1-38	26
150700001	H - 1-41	26
150701001	H - 1-43	26
150704001	H - 5-2	26
150705001	H - 5-10	28
150706001	H - 5-11	28
150711001	H - 5-13	28
150712001	H - 5-14	28
150715001	H - 5-16	28
150716001	H - 5-18	28
150717000	H - 5-19	28
150718001	H - 5-21	28

CODE	REF.NO.	Page
150719001	H - 9-2	28
150720001	H - 5-24	28
150721001	H - 5-25	28
150722001	H - 5-26	28
150723001	H - 5-27	28
150725001	H - 6	28
150726001	H - 7	28
151074009	B - 10-4	2
151478001	G-3	59
151479101	G-5	59
151481001	G7 - 5-2-1	24
151482001	G7 - 5-2-2	24
151483101	G-7	59
151486001	G-3	59
151487101	G7 - 5-2	24
	G-5	59
151571001	G3 - 5-2-3	16
151572101	G3 - 5-1-13	16
	G4 - 5-13	18
	G5 - 5-13	20
151602002	L1 - 9	34
	L2 - 9	38
151604001	Z1 - 11-1	50
151927001	C - 15	4
153675001	K - 1-1	32
	K - 29-1	32
153787001	G3 - 5-2-2	16
153965001	H - 5-28	28
154344201	H - 9-1	28
155510001	M1 - 26-1	44
	M1 - 26-2	44
	M1 - 58	44
	M2 - 26-1	48
	M2 - 26-2	48
155558001	E - 20	8
156112003	Z2 - 9-1-8	52
	Z2 - 9-2-8	54
156175001	G-3	59
156179101	G-5	59
156182101	G7 - 7-3	24
	G-7	59
156211101	G6 - 5-4	22
	G7 - 5-1-4	24
	G7 - 5-2-4	24
	G7 - 5-3-5	24
156792001	G1 - 5-1-2	12
	G1 - 5-2-3	12
159150009	D1 - 20	4
	D1 - 21	4
	D2 - 26	6
	D2 - 28	6
159583001	G-3	57
159584201	G-5	57
159587001	G4 - 5-7	18
159588001	G4 - 7-2	18
	G-7	57
159590001	G4 - 7-2-1	18
	G6 - 7-2-1	22
159609001	G4 - 14-2	18
	G6 - 14-2	22
	G-14	57
	G-14	58
159614001	G-3	58

brother®

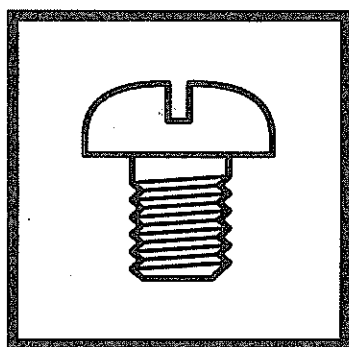

パーツブック
PARTS BOOK

ブラザー工業株式会社

BROTHER INDUSTRIES, LTD