

Teileliste und Näheinrichtungen
Spare Parts List and Sewing Equipment

269

DÜRKOPP ADLER AG

Postfach 17 03 51, D-33703 Bielefeld • Potsdamer Straße 190, D-33719 Bielefeld
Telefon (05 21) 9 25 - 0 • Telefax (05 21) 9 25 24 35



Teileliste und Näheinrichtungen
Spare Parts List and Sewing Equipment

269

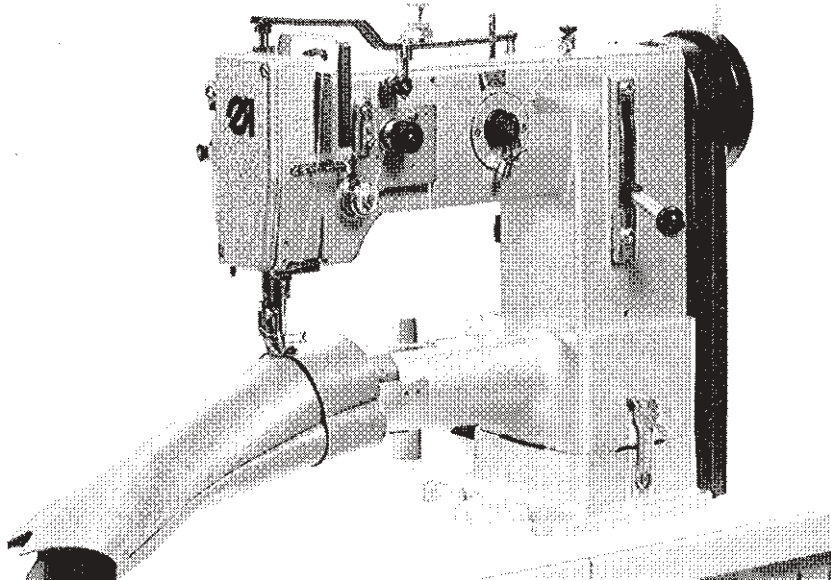

INFORMATION ZUR HANDHABUNG DER TEILELISTE

1. Allgemeines

1.1 Im Inhaltsverzeichnis sind die Teile-Nr. nach steigenden Nr. geordnet.

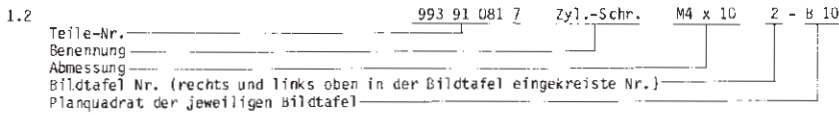

1.4 Bei Bestellung bitte Teile-Nr. mit Benennung angeben.

1.5 Zu einer Einheit gehörende Einzelteile sind durch eine strichpunktierte Linie eingerahmt. Die Einheit kann auch komplett unter der voll eingerahmten Teile-Nr. bestellt werden. Zu dieser Einheit gehören keine Teile, deren Nr. außerhalb der strichpunktierten Linie steht.

2.1 Verwendete Bildzeichen

N = nicht als Einzelteil lieferbar

Mg = mustergebunden, bei Ersatzteilebestellung bitte Muster einschicken oder Form-Nr. angeben

= siehe Mechanikeranleitung

= flüssig sichern, kleben, dichten
Loctite 270, Nr.990 49 034 6



= Länge oder Fläche



= ohne Fadenabschneider



= mit Fadenabschneider



= links



= rechts

← = Hinweis auf Unterscheidungsmerkmal

mm = Maße

V = veraltete Ausführung

a.W. = auf Wunsch



1 Nadel



2 Nadeln

2.3 Sollten Sie ein Teil nicht in der Ersatzteilliste auffinden, was durch technische Änderungen vorkommen kann, dann geben Sie uns bitte zur Teile- und Funktionsbeschreibung, evtl. Teil skizzieren, die genaue Unterklasse und Fabrik-Nr. lt. Typenschild bekannt.

3. Elektro-Teile

3.1 Bei Elektrokabeln und pneumatischen Schläuchen ist es erforderlich, die gewünschte Meterzahl anzugeben.

3.2 Bei Bestellungen von Elektroteilen bitten wir die zusätzlichen Angaben, die in Klammern hinter der Teile-Nr. stehen, mit anzugeben.

3.3 Elektroteile sind zum schnellen Auffinden im Lageplan mit einer Positions-Nr. gekennzeichnet. Die Teile sind wie in Punkt 1.5 beschrieben aufgeführt.

3.4 Nicht nummerierte Elektroteile können nach der Bezeichnung z.B. "Transistor T6" oder "Widerstand 1KΩ 0,5W" und der dazugehörigen Stromlaufplan-Nr. bestellt werden.

4. Auf Anfrage stehen weitere Ersatzteillisten zur Verfügung, zB.: für "Näharnaturen", "Apparate", "Zusatzeinrichtungen für Nähmaschinen" (elektrische und pneumatische Ausstattungen wie RAP, Antriebe usw.), Gestelle usw.

5. Jeder Nachdruck, auch der auszugsweise, ist nur mit unserer Genehmigung gestattet. Änderungen behalten wir uns vor.

INFORMATION ON USING THE SPARE PARTS LIST

1. In general

1.1 The part numbers are listed in numerical order in the table of contents.

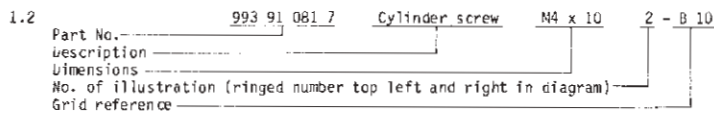

1.4 When ordering please quote the part number together with description.

1.5 The component parts belonging to a "unit" are shown enclosed within a dot-dash frame. A "unit" can also be ordered complete by quoting the fully enclosed number within the dot-dash frame. Any parts, the numbers of which are shown outside the dot-dash frame, are not included with the "unit" and must be ordered separately.

2.1 Symbols applied

N = not available as separate part

Mg = calls for a sample; when ordering a spare part please submit a sample or indicate the number of the shape

= see mechanics manual

= secure by glueing, seal
Loctite 270, No 990 49 034 6



= declare length or area



= without thread cutter



= with thread cutter



= left



= right

← = point of alteration

mm = measurement

V = obsolete

a.W. = on request



1 needle



2 needles

2.3 Should a part not be found in the spare parts list, possibly due to technical alteration, please describe the part and its function as fully as possible when ordering. Please quote also the sub-class and serial number according to the specification plate.

3. Electrical parts

3.1 Please quote the required length in meters for electric cables and pneumatic hoses.

3.2 When ordering electrical parts, please include the additional data in brackets behind the part number.

3.3 To facilitate quick location, electrical components are marked with a position number in the situation-plan in the upper right hand corner of each electro sheet. Please order as in 1.5.

3.4 Electrical parts which are not numbered can be ordered according to their specification, e.g. "Transistor T6" or "Resistor 1 KΩ 0.5 W" and the appropriate circuit plan.

4. On request, further spare parts lists are available, e.g. "Sewing components", "Attachments", Additional equipment for sewing machines" (electrical and pneumatic equipment, RAP, motors etc.), "Stands" etc.

5. All reproductions, whether whole or in part, require our permission. Technical specifications subject to alteration.

INSTRUCTIONS RELATIVES À L'UTILISATION DE LA LISTE DE PIÈCES DE RECHANGE

1. Généralités

1.1 Dans la table des matières, les numéros de pièces sont classés dans l'ordre croissant:

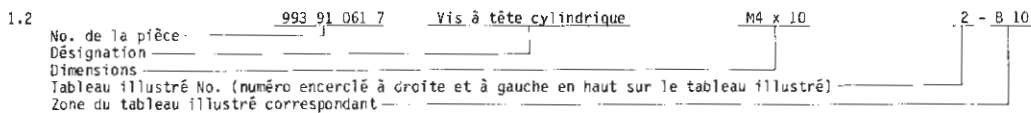

1.4 En cas de commandes indiquer sur le bon de commande le numéro de la pièce et la désignation correspondante.

1.5 Les pièces détachées faisant partie d'une unité sont encadrées d'une ligne en traits et points. L'unité peut aussi être commandée, sous le numéro entièrement encadré (dans une case), comme unité complète. Cette unité ne comprend pas les pièces dont le numéro est marqué à l'extérieur de la ligne en traits et points.

2.1 Symboles utilisés

N = non livrable comme pièce indivie

MG = nécessite un échantillon; lorsque vous commandez une pièce de rechange veuillez soumettre un échantillon ou spécifiez le numéro de la forme

= voir instructions pour le mécanicien

= coller, fermer hermétiquement
Loctite 270, No. 99049 034 6



= indiquer longueur ou surface



= sans coupe-fil



= avec coupe-fil



= gauche



= droite

= indication pour point de variation

mm = mesures

V = ancien model

Q.W. = sur demande



1 aiguille



2 aiguilles

2.3 Pour le cas où vous ne trouveriez pas une pièce dans la liste des pièces de rechange, ce qui pourrait arriver à la suite de modifications techniques, nous vous prions de nous fournir, avec la description des pièces et du fonctionnement, des croquis des pièces éventuels, la sous-classe exacte et le numéro d'usine, tel qu'il est marqué sur la plaquette de type.

3. Pièces de la partie électrique

3.1 Pour les câbles électriques et les tuyaux pneumatiques, il est indispensable de nous communiquer le nombre de mètres désiré.

3.2 Veuillez nous préciser, dans les commandes de pièces pour la partie électrique, les indications supplémentaires marquées entre parenthèses après les numéros de pièces.

3.3 Les pièces de la partie électrique sont repérées par un numéro de position, afin qu'il soit possible de les trouver rapidement sur le plan de position. Les pièces sont indiquées comme mentionné au point 1.5.

3.4 Les pièces de la partie électrique non numérotées peuvent être commandées selon la désignation, par exemple "Transistor T6" ou "Résistance 1 K Ω 0,5 W" et le numéro du schéma développé correspondant.

4. Sur demande, d'autres listes de pièces de rechange sont mise à votre disposition, par exemple "Garnitures de couture", "Appareils", "Équipement supplémentaires pour les machines à coudre" (équipement électrique et pneumatique comme RAP, moteurs etc.) bâtis etc.

5. Toute réimpression, même partielle, est interdite sans notre autorisation. Nous nous réservons le droit de procéder à des changements.

INFORMACIONES RELATIVAS A LA UTILIZACIÓN DE LA LISTA DE LAS PIEZAS DE RECAMBIO

1. Informaciones generales

1.1 En el índice, los números de las piezas de recambio están especificados en el orden creciente.

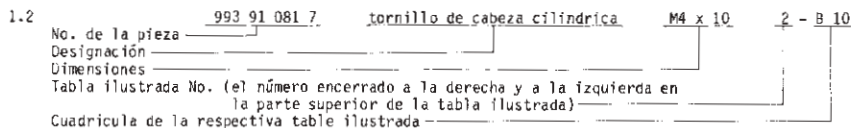

1.4 Indicar en el pedido el número de la pieza y la designación.

1.5 Las piezas individuales que pertenecen a una unidad están encerrados por una línea de trazos y puntos. Es también posible pedir la unidad completa precisando el número de la pieza enteramente encerrado. Esta unidad no incluye las piezas cuyo número se encuentra fuera de la línea de trazos y puntos.

2.1 Símbolos empleados

N = No se entrega como pieza individual

MG = Exige la muestra, al pedir la pieza de recambio hay que someter la muestra o precisar el número de la forma

= Véase Instrucciones para el mecánico

= Asegurar con líquido, pegar, obturar
Loctite 270, no990 49 034 6



= Indicar largo y superficie



= Sin cortahilos



= Con cortahilos



= izquierda



= derecha

= Advertencia de que hay

mm = medidas

V = Estado de fabricación anticuado

Q.W. = a petición



1 aguja



2 agujas

2.3 Si Ud. no puede encontrar una pieza en la lista de las piezas de recambio, lo que es posible en caso de modificaciones técnicas, entonces rogamos describir la pieza y el funcionamiento y bosquejar eventualmente la pieza y especificar la sub-clase y el número de fabricación según la placa indicadora de tipo.

3. Piezas del sistema eléctrico

3.1 En caso de cables eléctricos y de tubos neumáticos hay que indicar el largo deseado en metros.

3.2 Al pedir piezas eléctricas, precisar también los detalles contenidos entre paréntesis detrás del número de la pieza.

3.3 Las piezas del sistema eléctrico llevan un número de referencia. Así es posible localizarlas más rápidamente en el plano de posición. Las piezas son indicadas según el punto 1.5.

3.4 Las piezas eléctricas no numeradas pueden ser pedidas indicando la designación, por ejemplo "Transistor T6" o "resistencia 1K Ω 0,5 W" así como el número del esquema de los circuitos.

4. A petición, se tiene además a su disposición listas de las piezas de recambio, por ejemplo "Equipo de coser", "Aparatos", "Equipo suplementario para máquinas de coser" (equipo eléctrico y neumático como RAP, motores etc.) las bancadas etc.

5. Está prohibida toda reproducción, incluso parcial, sin nuestra autorización. Nos reservamos el derecho de proceder a modificaciones.

INFORMAZIONE PER L'UTILIZZAZIONE DEL LIBRETTO PARTI DI RICAMBIO

1. Generalità

1.1 Nell'indice i numeri dei pezzi sono ordinati secondo numero progressivo.

1.2

	993 91 081 7	vite-cil.	M4 x 10	2 - B 10
Numero del pezzo				
Denominazione				
Misure				
Numero della tavola di raffigurazione (Numero nel cerchio a sinistra od a destra della tavola di raffigurazione).				
Quadrato di localizzazione nella tavola di raffigurazione corrispondente				

1.4 Per l'ordine indicare il numero del pezzo e la sua denominazione.

1.5 Pezzi singoli componenti un gruppo sono racchiusi in una linea a punti e tratti. Il gruppo può essere anche ordinato completo indicando all'ordine il numero di pezzo incorniciato da una linea continua. I pezzi il cui numero è situato fuori della linea a punti e tratti non appartengono al gruppo.

2.1 Abbreviazioni e simboli utilizzati:

N = Non fornibile come pezzo singolo

MG = Dipendente dal campione, ordinando i pezzi di ricambio. Inviare un campione oppure indicare il numero di forma

= vedi libretto istruzioni per, meccanici

= Fissaggio, incollaggio o tenuta del pezzo tramite liquido Loctite 270, Nr. 990 48 034 6



= Indicare la lunghezza o la superficie



= Senza rasafilo



= Con rasafilo



= Sinistra (o)



= Destra (o)

= Indicazione per notare le differenze tra i pezzi

mm = Misura

V = Esecuzione invecchiata

d.W. = A richiesta



1 ago



2 aghi

2.3 Nel caso che un pezzo non si trovi nel libretto parti di ricambio, caso che può accadere a causa delle continue innovazioni tecniche, indicate, accanto alla descrizione della funzione del pezzo e l'eventuale schizzo o descrizione minuta del pezzo, la classe e sottoclasse esatta ed il numero di fabbricazione riportati in targhetta

3. Componenti elettrici

3.1 Ordinando cavi elettrici o tubi pneumatici è necessario indicare la lunghezza in metri.

3.2 Ordinando componenti elettrici indicare i dati suppletivi segnati in parentesi dietro il numero del pezzo.

3.3 I componenti elettrici sono contrassegnati con un numero di posizione nella planimetria per facilitare e sveltire la loro localizzazione. I pezzi sono contraddistinti come descritto nel punto 1.5.

3.4 Componenti elettrici non numerati possono essere ordinati sotto il simbolo dello schema elettrico per esempio "Transistor T6" oppure "Resistenza 1KΩ 0,5W" indicando suppletivamente il numero dello schema elettrico al quale i componenti appartengono.

4. A richiesta, esistono ulteriori libretti di parti di ricambio per esempio "Organi di cucitura", "Apparecchiature", "Apparecchiature supplementari per le macchine per cucire" (equipaggiamenti elettrici e pneumatici, RAP, motori etc.) sostegni etc.

5. Ogni riproduzione intera o parziale è permessa solo con la nostra approvazione. Ci riserviamo ogni diritto di modifica.

Gruppe : B

AUFTEILUNG UND REIHENFOLGE DER BILDTAFELN

Breakdown and sequence of the illustrations

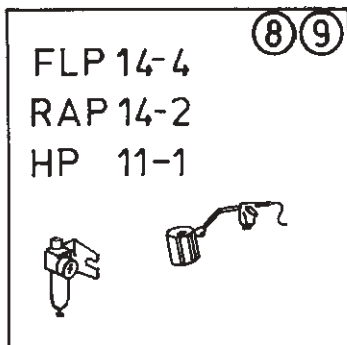
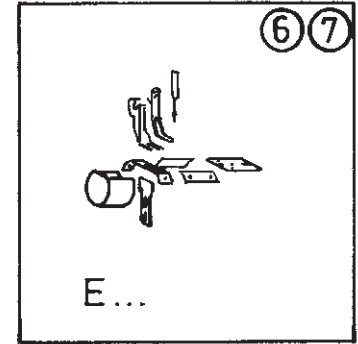
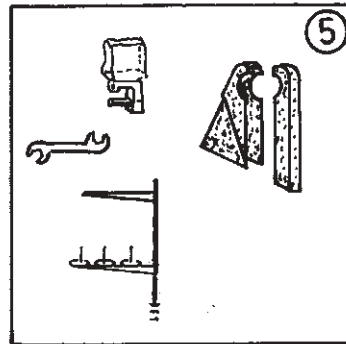
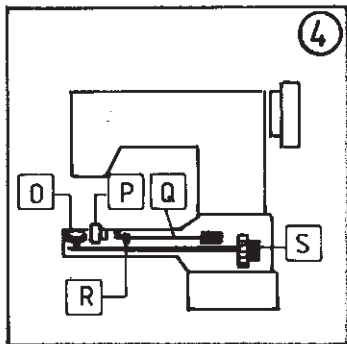
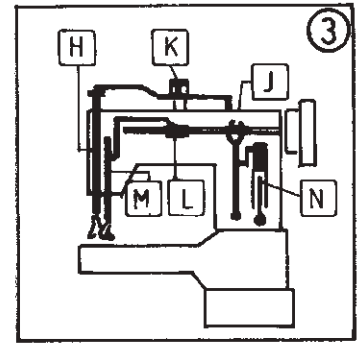
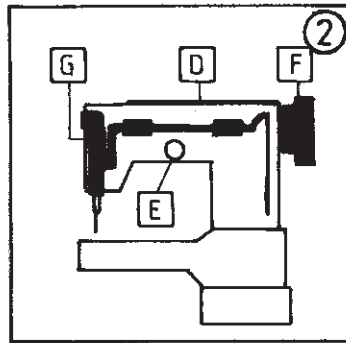
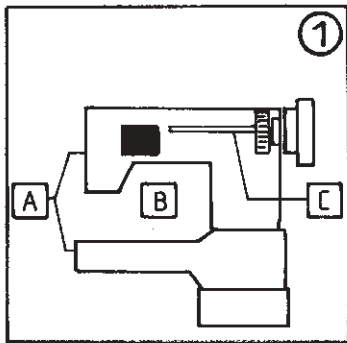

Unterklassen Tabelle, Table of sub classes

269		Gruppenaufstellung der Unterklassen z.B: A1 Table of sub class (for example A 1)																	E...					
		A	B	C	D	E	F	G	H	J	K	L	M	N	O	P	Q	R	S	X	(6)	(7)	(8)	(9)
1	-73	1	2	1	1	1	1	2	3	1	1	1	1	1	1	1	1	1	1	X	X			
2	-363	2	2	1	1	1	1	1	2	1	2	1	1	1	3	1	1	1	1	X	X			
3	-373	1	2	1	1	1	1	2	3	1	1	1	1	1	2	1	1	1	1	X	X		X	X
4																								
5																								
6																								
7																								
8	-262	3	1	1	1	1	1	1	1	1	1	1	1	4	1	2	1	1	X	X				
9	-273	4	1	1	1	1	1	3	3	1	1	1	1	1	4	1	2	1	X	X	X	X	X	

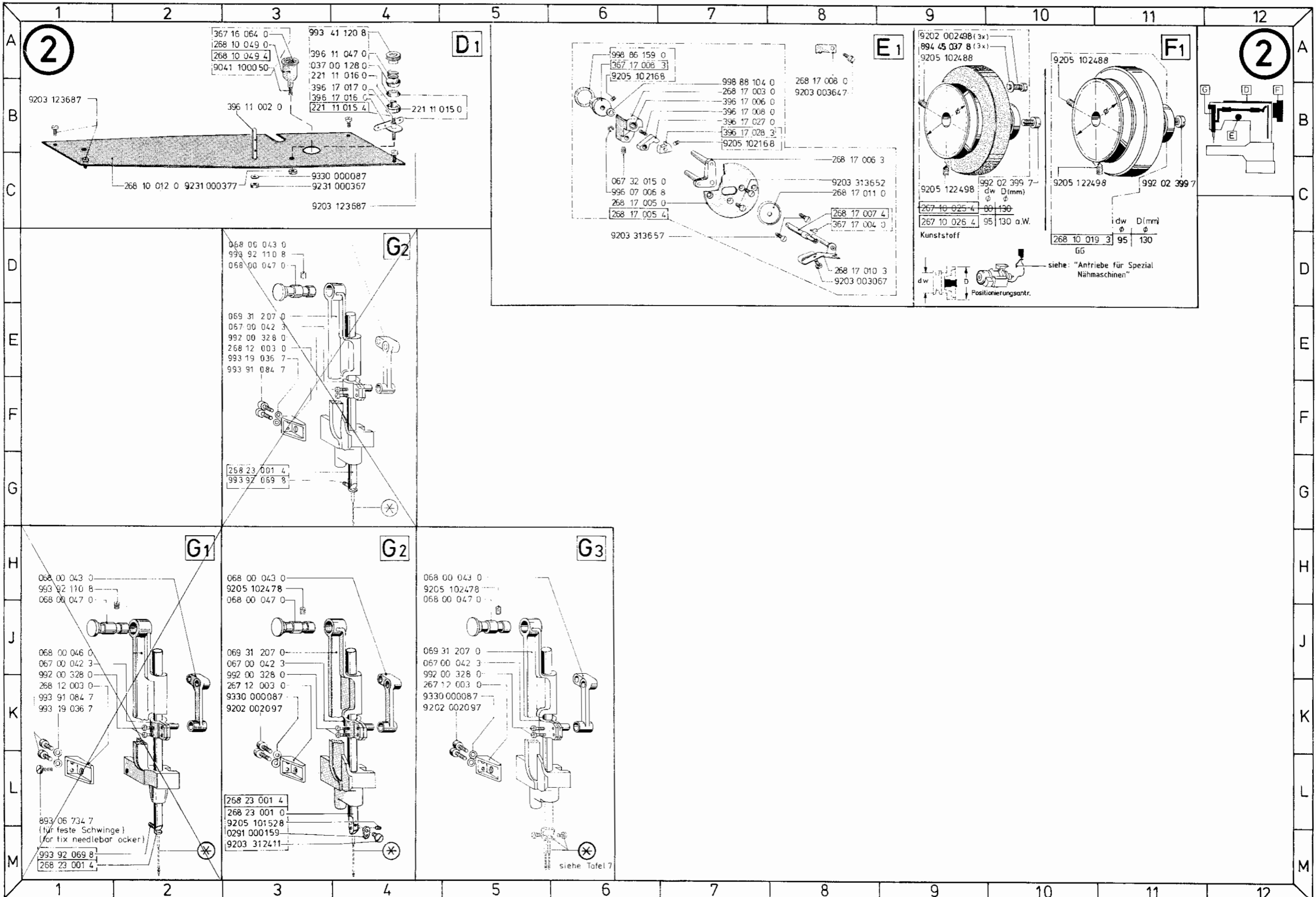

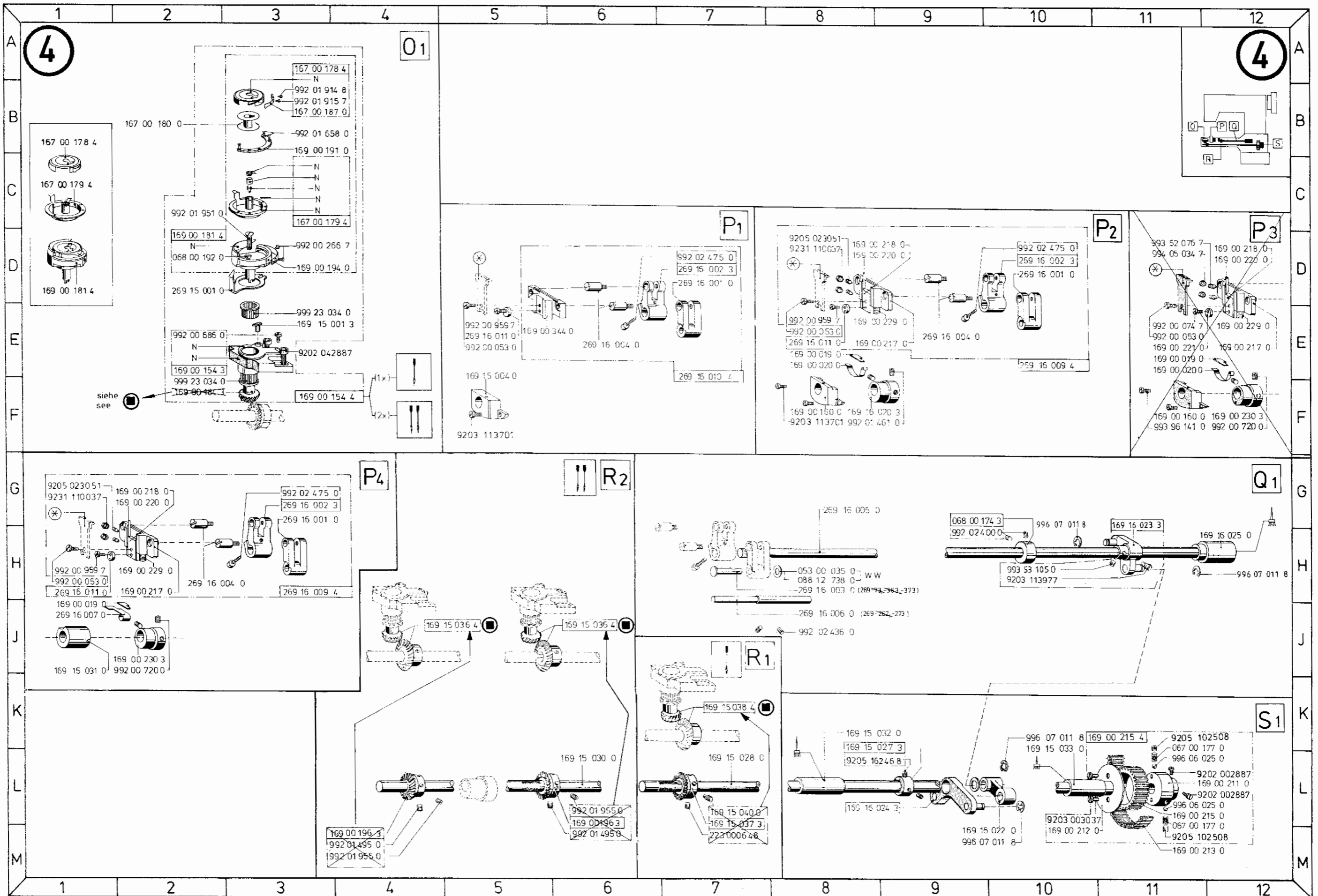

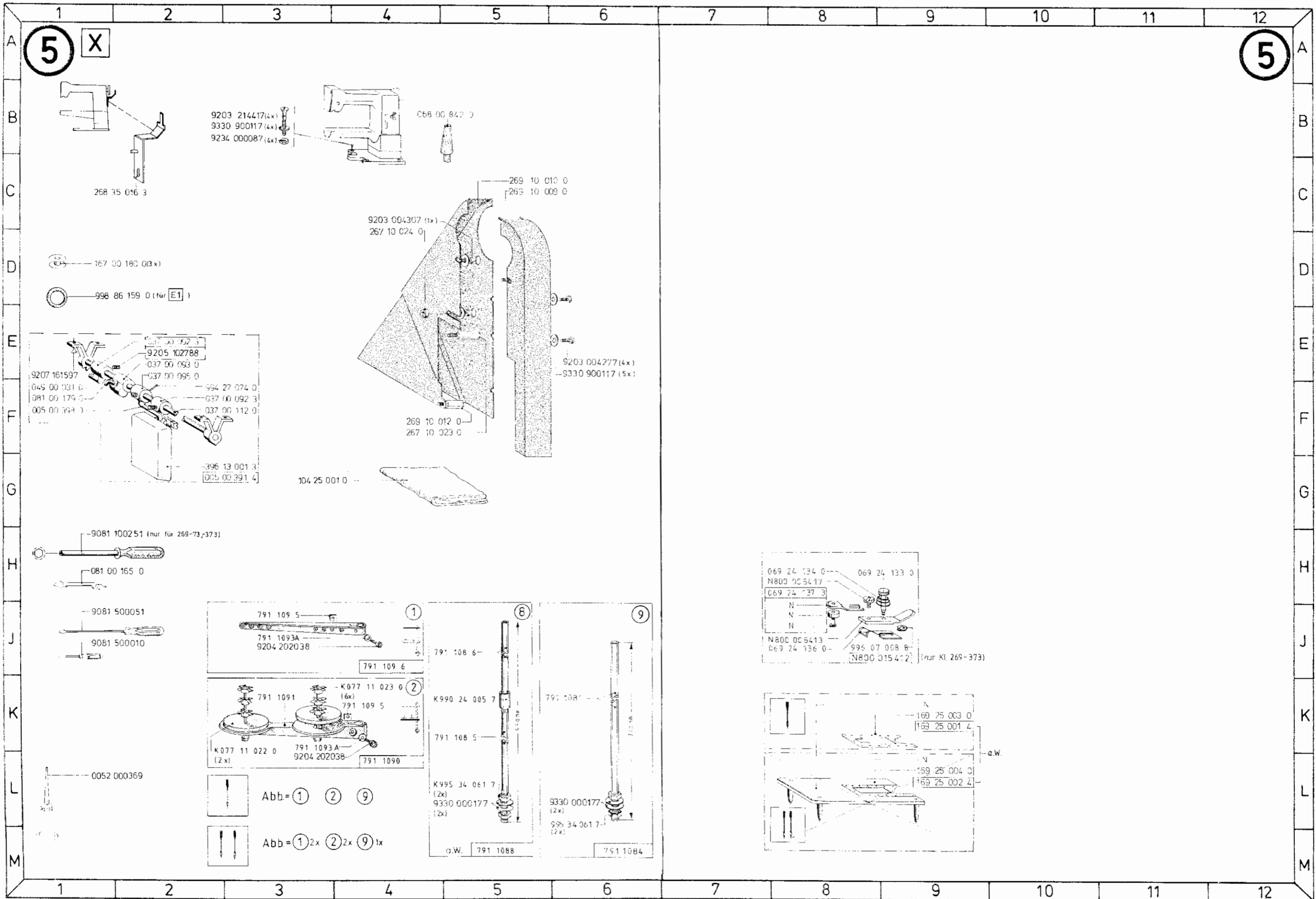

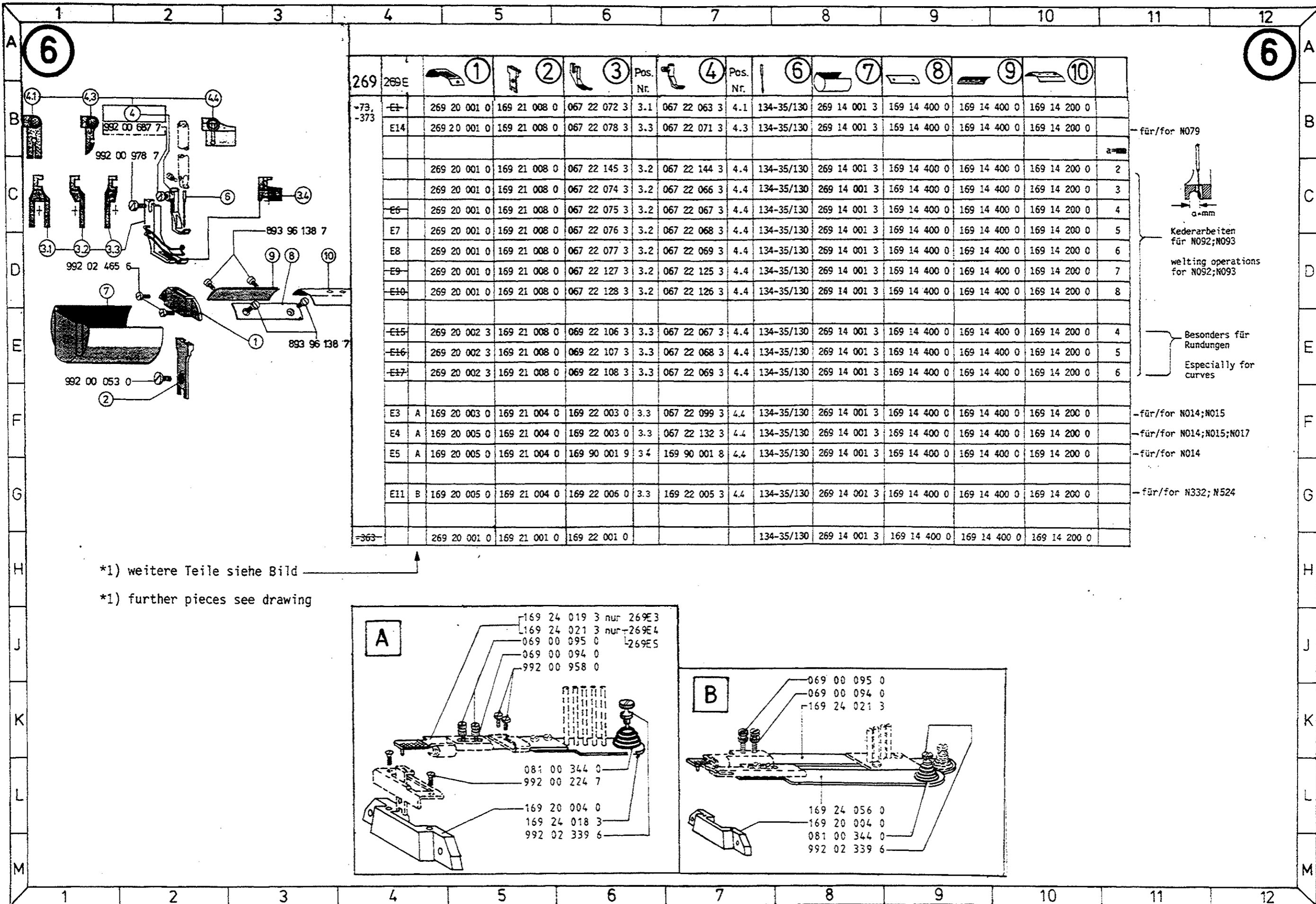

269	269E	①	②	③	Pos. Nr.	④	Pos. Nr.	⑥	⑦	⑧	⑨	⑩
-73, -373	E1	269 20 001 0	169 21 008 0	067 22 072 3	3.1	067 22 063 3	4.1	134-35/130	269 14 001 3	169 14 400 0	169 14 400 0	169 14 200 0
	E14	269 20 001 0	169 21 008 0	067 22 078 3	3.3	067 22 071 3	4.3	134-35/130	269 14 001 3	169 14 400 0	169 14 400 0	169 14 200 0
		269 20 001 0	169 21 008 0	067 22 145 3	3.2	067 22 144 3	4.4	134-35/130	269 14 001 3	169 14 400 0	169 14 400 0	169 14 200 0
		269 20 001 0	169 21 008 0	067 22 074 3	3.2	067 22 066 3	4.4	134-35/130	269 14 001 3	169 14 400 0	169 14 400 0	169 14 200 0
	E6	269 20 001 0	169 21 008 0	067 22 075 3	3.2	067 22 067 3	4.4	134-35/130	269 14 001 3	169 14 400 0	169 14 400 0	169 14 200 0
	E7	269 20 001 0	169 21 008 0	067 22 076 3	3.2	067 22 068 3	4.4	134-35/130	269 14 001 3	169 14 400 0	169 14 400 0	169 14 200 0
	E8	269 20 001 0	169 21 008 0	067 22 077 3	3.2	067 22 069 3	4.4	134-35/130	269 14 001 3	169 14 400 0	169 14 400 0	169 14 200 0
	E9	269 20 001 0	169 21 008 0	067 22 127 3	3.2	067 22 125 3	4.4	134-35/130	269 14 001 3	169 14 400 0	169 14 400 0	169 14 200 0
	E10	269 20 001 0	169 21 008 0	067 22 128 3	3.2	067 22 126 3	4.4	134-35/130	269 14 001 3	169 14 400 0	169 14 400 0	169 14 200 0
		269 20 002 3	169 21 008 0	069 22 106 3	3.3	067 22 067 3	4.4	134-35/130	269 14 001 3	169 14 400 0	169 14 400 0	169 14 200 0
	E15	269 20 002 3	169 21 008 0	069 22 107 3	3.3	067 22 068 3	4.4	134-35/130	269 14 001 3	169 14 400 0	169 14 400 0	169 14 200 0
	E16	269 20 002 3	169 21 008 0	069 22 108 3	3.3	067 22 069 3	4.4	134-35/130	269 14 001 3	169 14 400 0	169 14 400 0	169 14 200 0
	E17	269 20 002 3	169 21 008 0	069 22 108 3	3.3	067 22 069 3	4.4	134-35/130	269 14 001 3	169 14 400 0	169 14 400 0	169 14 200 0
	E3	A 169 20 003 0	169 21 004 0	169 22 003 0	3.3	067 22 099 3	4.4	134-35/130	269 14 001 3	169 14 400 0	169 14 400 0	169 14 200 0
	E4	A 169 20 005 0	169 21 004 0	169 22 003 0	3.3	067 22 132 3	4.4	134-35/130	269 14 001 3	169 14 400 0	169 14 400 0	169 14 200 0
	E5	A 169 20 005 0	169 21 004 0	169 90 001 9	3.4	169 90 001 8	4.4	134-35/130	269 14 001 3	169 14 400 0	169 14 400 0	169 14 200 0
	E11	B 169 20 005 0	169 21 004 0	169 22 006 0	3.3	169 22 005 3	4.4	134-35/130	269 14 001 3	169 14 400 0	169 14 400 0	169 14 200 0
-363-		269 20 001 0	169 21 001 0	169 22 001 0				134-35/130	269 14 001 3	169 14 400 0	169 14 400 0	169 14 200 0

-für/for N079

Kederarbeiten für N092;N093
welding operations for N092;N093

Besonders für Rundungen
Especially for curves

*1) weitere Teile siehe Bild
*1) further pieces see drawing

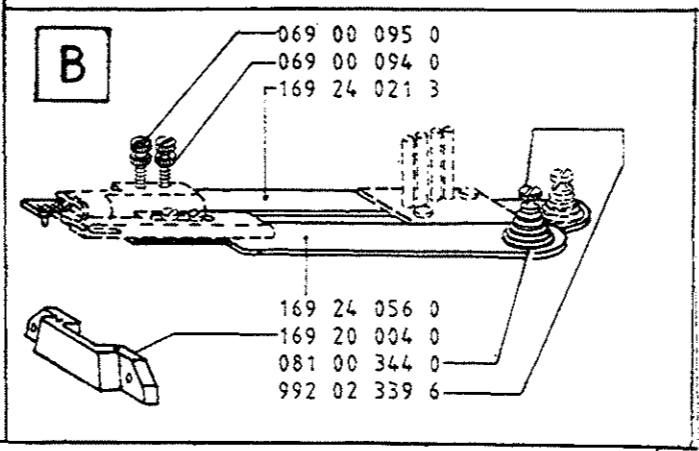
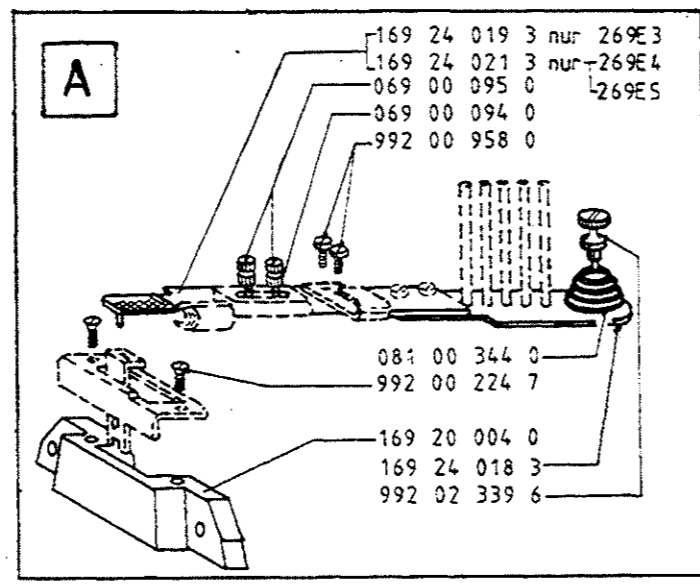

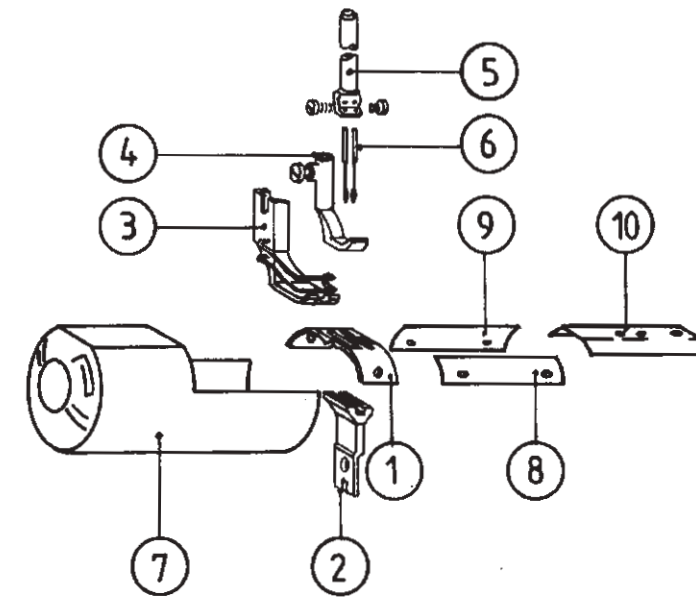

1	Stichplatte	Throat Plate	Plaque Aiguille	Placa Aguja
2	Transporteur	Feed Dog	Griffe	Arrastre
3	Druckerfuss	Presser Foot	Pied Presseur	Prensatela
4	Transportfuss	Foot	Pied Presseur	Pie Arrastre
5	Nadelstange	Needle Bar	Barre A Aiguill	Barra Aguja
6	Nadel	Needle	Aiguille	Aguja
7	Kappe	Cap	Capuchon	Tapa
8	Traeger	Carrier	Support	Soporte
9	Traeger	Carrier	Support	Soporte
10	Schieber	Slide	Coulisseau	Pasador

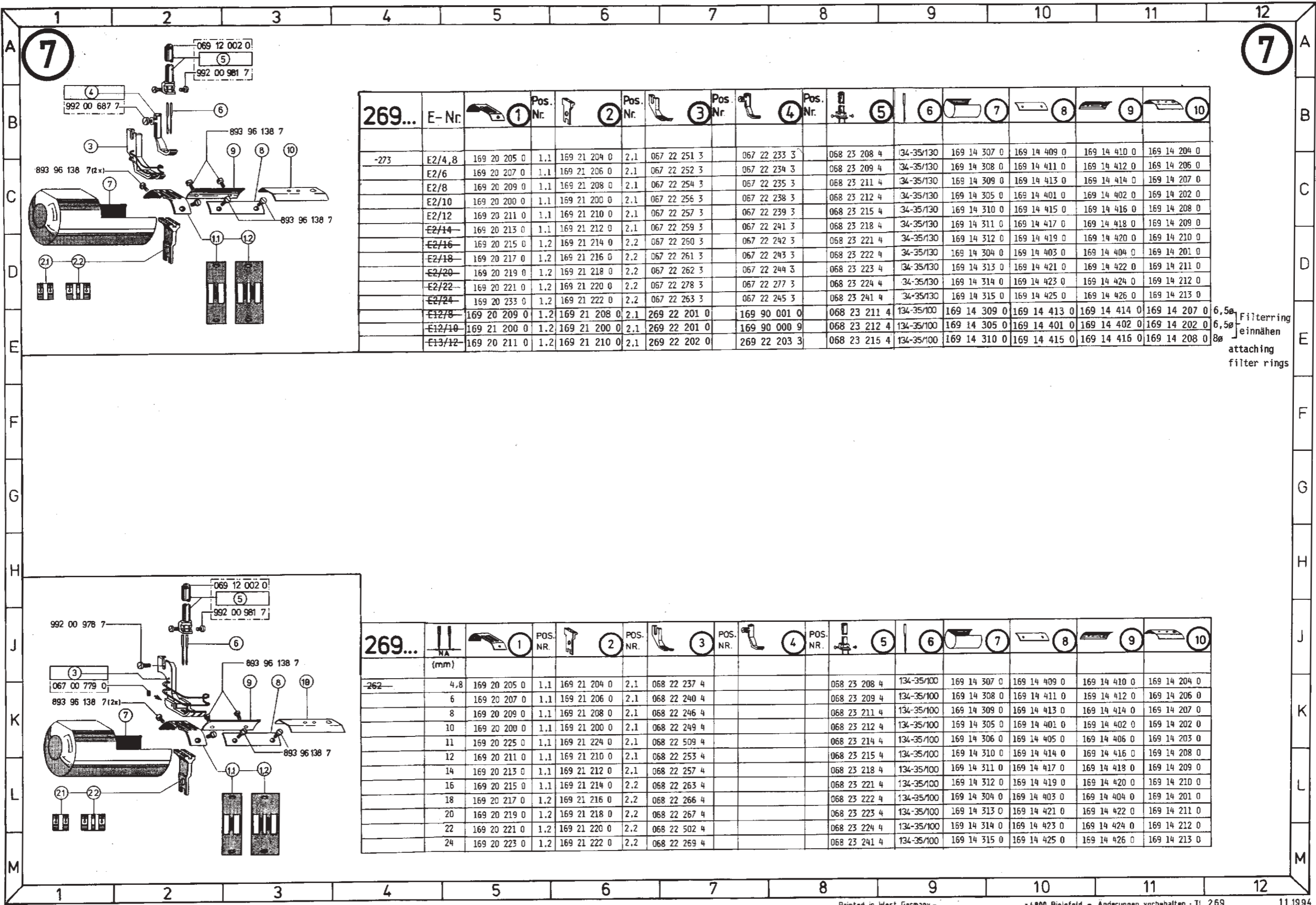

269...	E-Nr.	1	Pos. Nr.	2	Pos. Nr.	3	Pos. Nr.	4	Pos. Nr.	5	6	7	8	9	10
-273	E2/4,8	169 20 205 0	1.1	169 21 204 0	2.1	067 22 251 3		067 22 233 3		068 23 208 4	34-35/130	169 14 307 0	169 14 409 0	169 14 410 0	169 14 204 0
	E2/6	169 20 207 0	1.1	169 21 206 0	2.1	067 22 252 3		067 22 234 3		068 23 209 4	34-35/130	169 14 308 0	169 14 411 0	169 14 412 0	169 14 206 0
	E2/8	169 20 209 0	1.1	169 21 208 0	2.1	067 22 254 3		067 22 235 3		068 23 211 4	34-35/130	169 14 309 0	169 14 413 0	169 14 414 0	169 14 207 0
	E2/10	169 20 200 0	1.1	169 21 200 0	2.1	067 22 256 3		067 22 238 3		068 23 212 4	34-35/130	169 14 305 0	169 14 401 0	169 14 402 0	169 14 202 0
	E2/12	169 20 211 0	1.1	169 21 210 0	2.1	067 22 257 3		067 22 239 3		068 23 215 4	34-35/130	169 14 310 0	169 14 415 0	169 14 416 0	169 14 208 0
	E2/14	169 20 213 0	1.1	169 21 212 0	2.1	067 22 259 3		067 22 241 3		068 23 218 4	34-35/130	169 14 311 0	169 14 417 0	169 14 418 0	169 14 209 0
	E2/16	169 20 215 0	1.2	169 21 214 0	2.2	067 22 260 3		067 22 242 3		068 23 221 4	34-35/130	169 14 312 0	169 14 419 0	169 14 420 0	169 14 210 0
	E2/18	169 20 217 0	1.2	169 21 216 0	2.2	067 22 261 3		067 22 243 3		068 23 222 4	34-35/130	169 14 304 0	169 14 403 0	169 14 404 0	169 14 201 0
	E2/20	169 20 219 0	1.2	169 21 218 0	2.2	067 22 262 3		067 22 244 3		068 23 223 4	34-35/130	169 14 313 0	169 14 421 0	169 14 422 0	169 14 211 0
	E2/22	169 20 221 0	1.2	169 21 220 0	2.2	067 22 278 3		067 22 277 3		068 23 224 4	34-35/130	169 14 314 0	169 14 423 0	169 14 424 0	169 14 212 0
	E2/24	169 20 233 0	1.2	169 21 222 0	2.2	067 22 263 3		067 22 245 3		068 23 241 4	34-35/130	169 14 315 0	169 14 425 0	169 14 426 0	169 14 213 0
	E12/8	169 20 209 0	1.2	169 21 208 0	2.1	269 22 201 0		169 90 001 0		068 23 211 4	134-35/100	169 14 309 0	169 14 413 0	169 14 414 0	169 14 207 0
	E12/10	169 21 200 0	1.2	169 21 200 0	2.1	269 22 201 0		169 90 000 9		068 23 212 4	134-35/100	169 14 305 0	169 14 401 0	169 14 402 0	169 14 202 0
	E13/12	169 20 211 0	1.2	169 21 210 0	2.1	269 22 202 0		269 22 203 3		068 23 215 4	134-35/100	169 14 310 0	169 14 415 0	169 14 416 0	169 14 208 0

6,5a } Filterring
 6,5b } einnähen
 8a } attaching
 filter rings

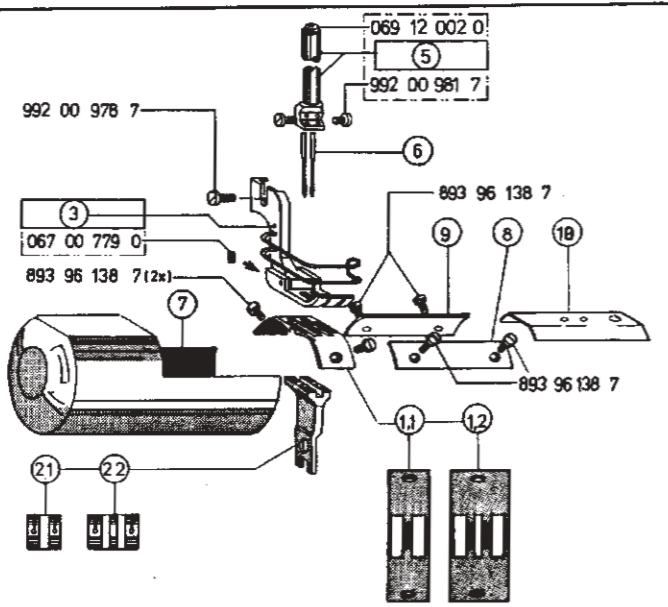

269...	NA (mm)	1	Pos. Nr.	2	Pos. Nr.	3	Pos. Nr.	4	Pos. Nr.	5	6	7	8	9	10
-262-	4,8	169 20 205 0	1.1	169 21 204 0	2.1	068 22 237 4				068 23 208 4	134-35/100	169 14 307 0	169 14 409 0	169 14 410 0	169 14 204 0
	6	169 20 207 0	1.1	169 21 206 0	2.1	068 22 240 4				068 23 209 4	134-35/100	169 14 308 0	169 14 411 0	169 14 412 0	169 14 206 0
	8	169 20 209 0	1.1	169 21 208 0	2.1	068 22 246 4				068 23 211 4	134-35/100	169 14 309 0	169 14 413 0	169 14 414 0	169 14 207 0
	10	169 20 200 0	1.1	169 21 200 0	2.1	068 22 249 4				068 23 212 4	134-35/100	169 14 305 0	169 14 401 0	169 14 402 0	169 14 202 0
	11	169 20 225 0	1.1	169 21 224 0	2.1	068 22 509 4				068 23 214 4	134-35/100	169 14 306 0	169 14 405 0	169 14 406 0	169 14 203 0
	12	169 20 211 0	1.1	169 21 210 0	2.1	068 22 253 4				068 23 215 4	134-35/100	169 14 310 0	169 14 414 0	169 14 416 0	169 14 208 0
	14	169 20 213 0	1.1	169 21 212 0	2.1	068 22 257 4				068 23 218 4	134-35/100	169 14 311 0	169 14 417 0	169 14 418 0	169 14 209 0
	16	169 20 215 0	1.1	169 21 214 0	2.2	068 22 263 4				068 23 221 4	134-35/100	169 14 312 0	169 14 419 0	169 14 420 0	169 14 210 0
	18	169 20 217 0	1.2	169 21 216 0	2.2	068 22 266 4				068 23 222 4	134-35/100	169 14 304 0	169 14 403 0	169 14 404 0	169 14 201 0
	20	169 20 219 0	1.2	169 21 218 0	2.2	068 22 267 4				068 23 223 4	134-35/100	169 14 313 0	169 14 421 0	169 14 422 0	169 14 211 0
	22	169 20 221 0	1.2	169 21 220 0	2.2	068 22 502 4				068 23 224 4	134-35/100	169 14 314 0	169 14 423 0	169 14 424 0	169 14 212 0
	24	169 20 223 0	1.2	169 21 222 0	2.2	068 22 269 4				068 23 241 4	134-35/100	169 14 315 0	169 14 425 0	169 14 426 0	169 14 213 0

8

8

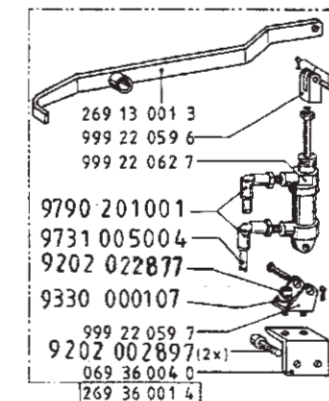
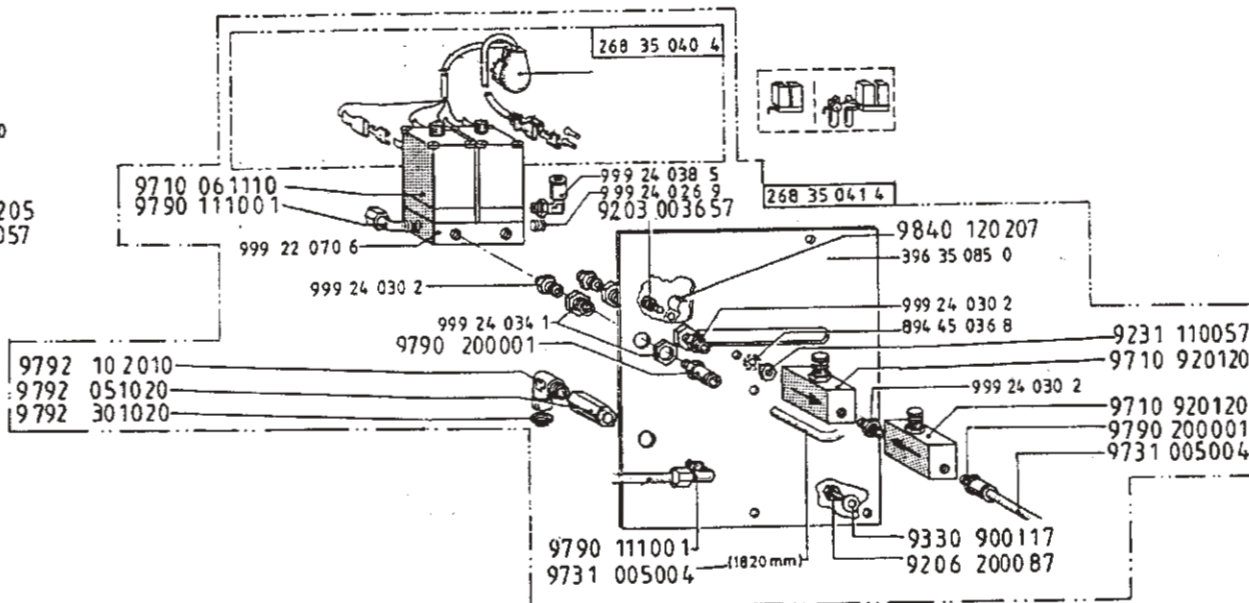
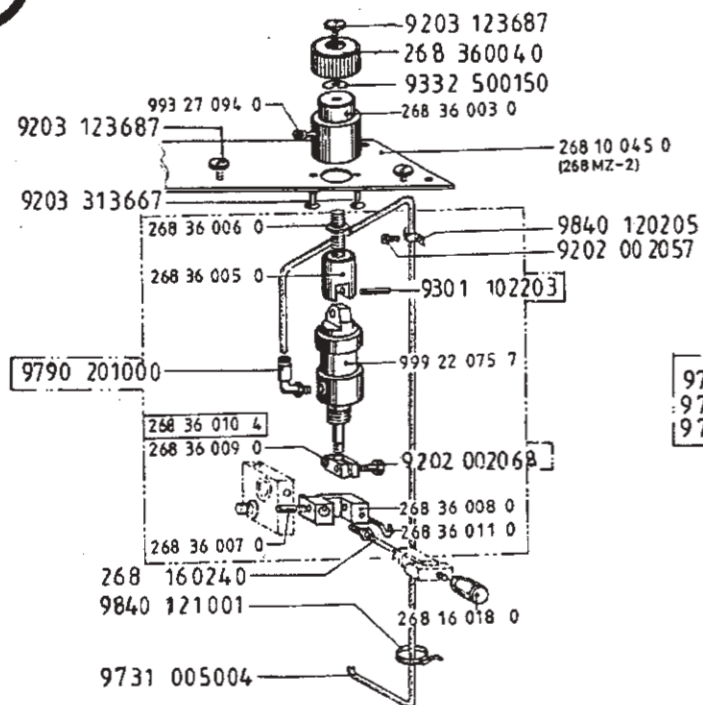

RAP 14-2
269 36 7819

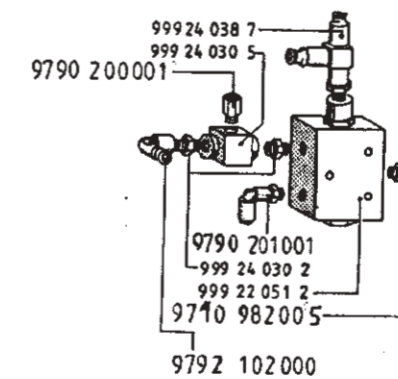
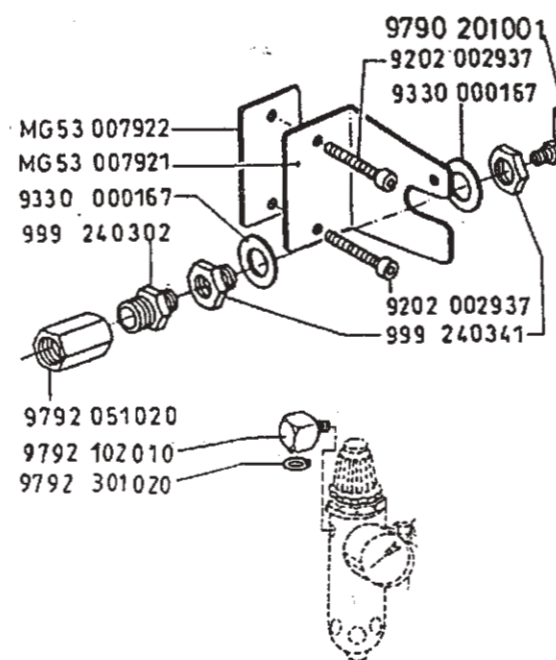
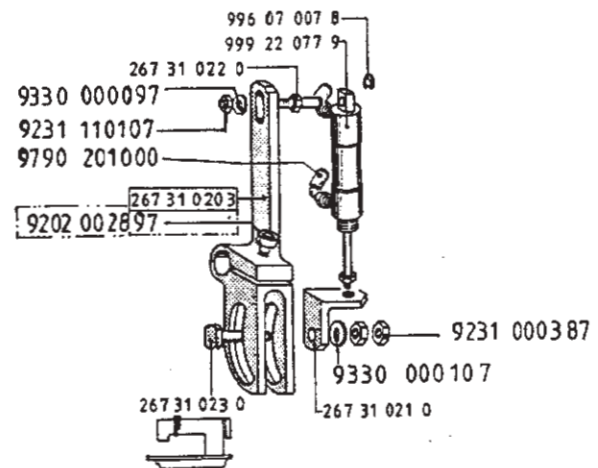
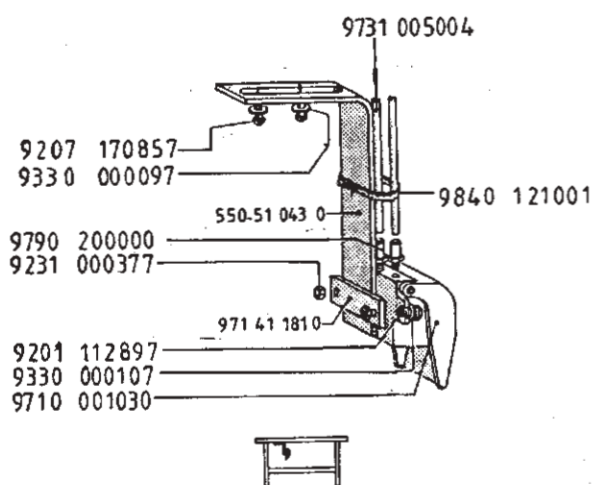

HP 11-1
267 36 7529

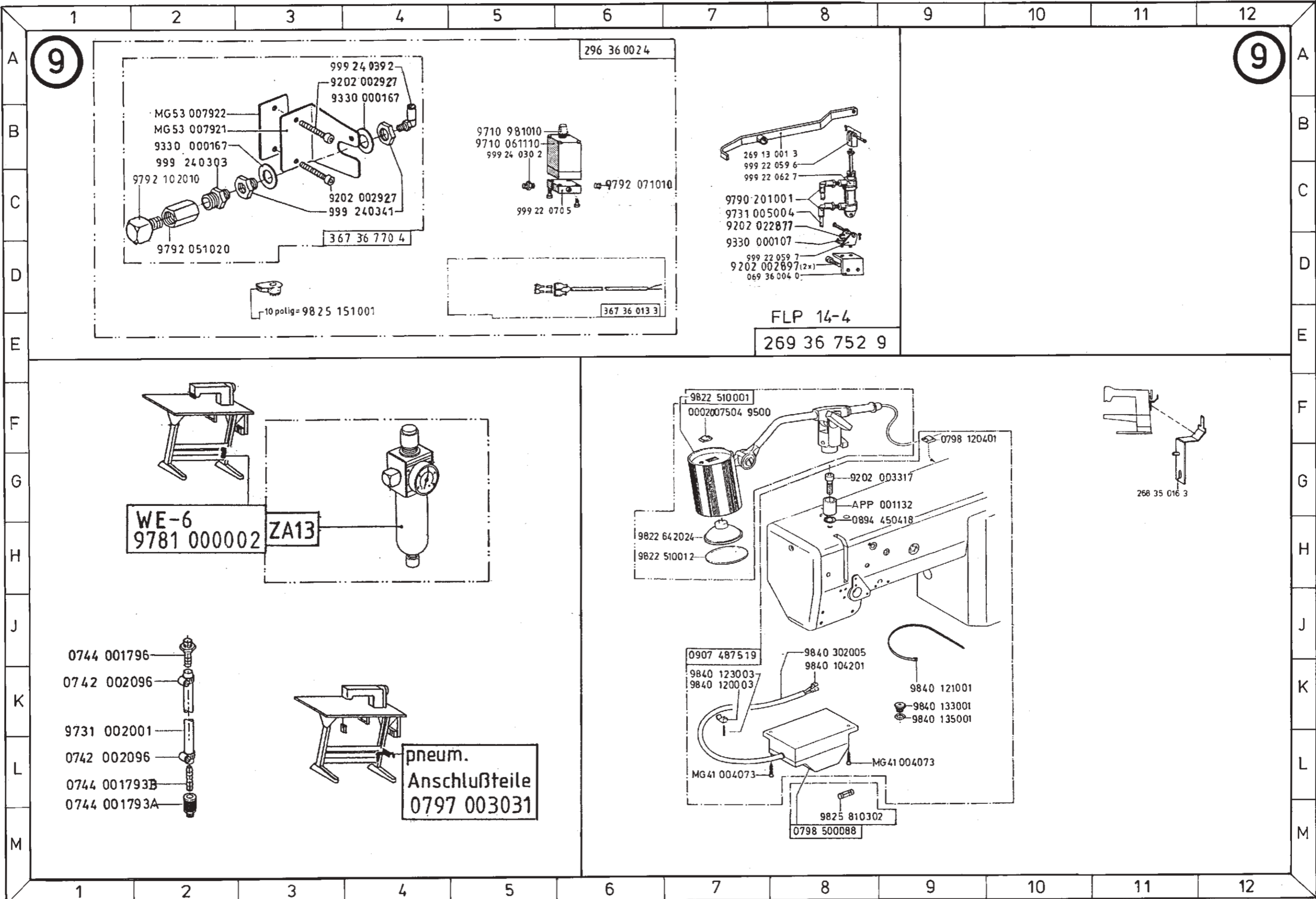

9

9

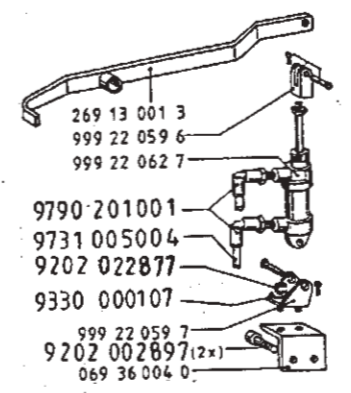
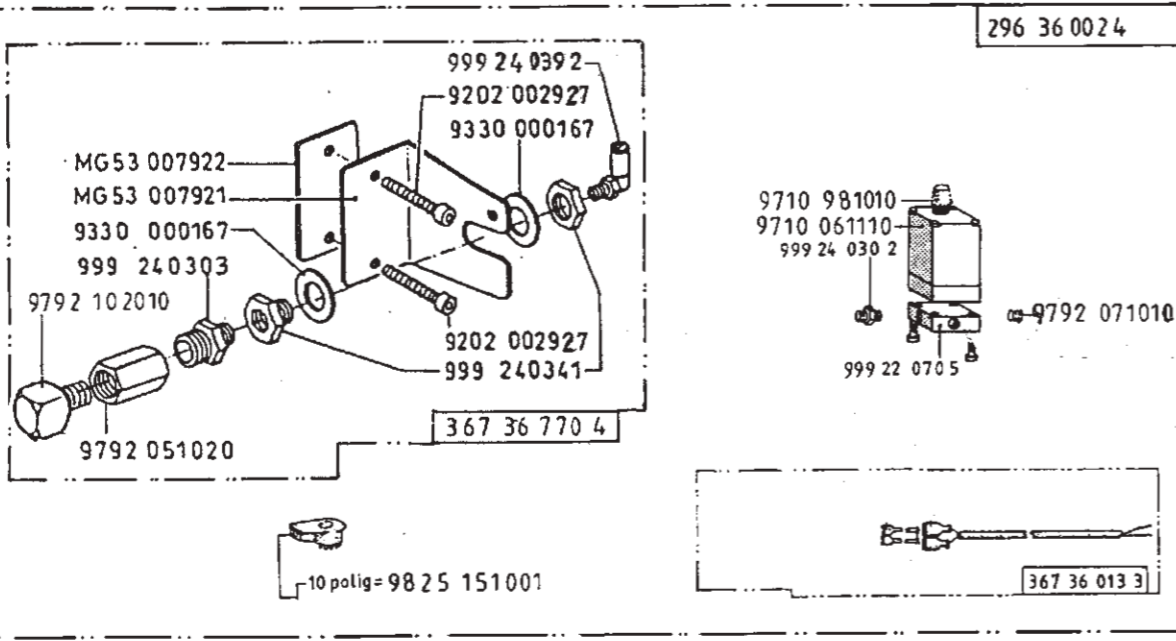

FLP 14-4
269 36 752 9

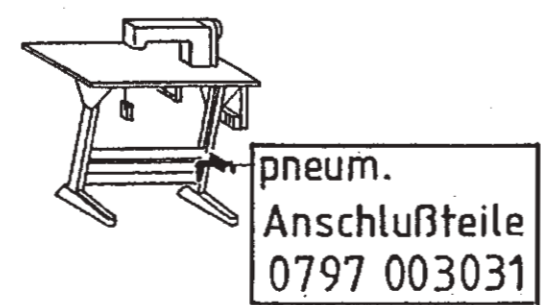
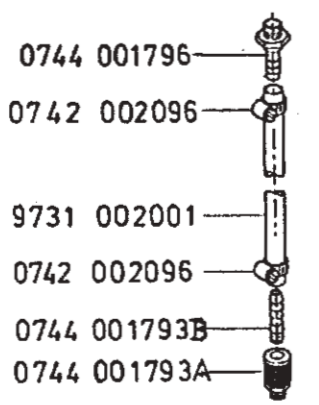
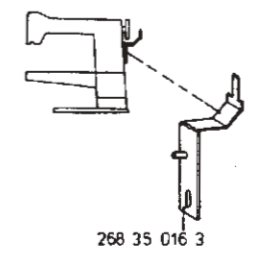
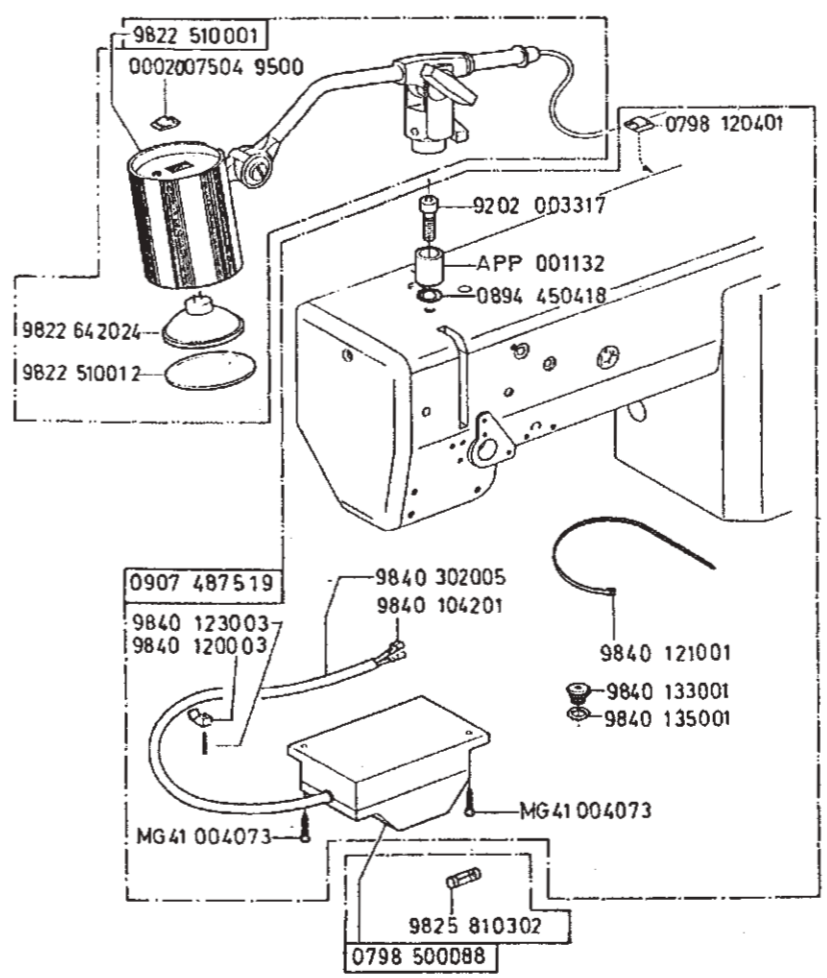
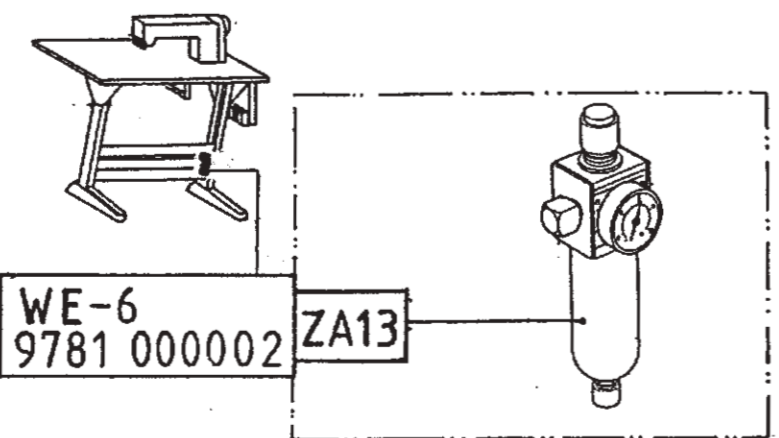

Teile-Nr.	Benennung	Bildtafel	Teile-Nr.	Benennung	Bildtafel
K1. 269					
K005 00 391 4	KNIEHEBEL KNEE LEVER	5G3	K067 00 456 0	SCHEIBE DISC	3B5
K005 00 398 0	STANGE ROD	5F5	K067 10 001 4	ARMWELLE ARM SHAFT	1M3
K016 00 401 0	SCHEIBE DISC FILZ	1D8 1D11	K067 10 005 0	SCHEIBE DISC	1K5
K037 00 015 0	STOFFOR STANGE FOOT BAR	3B2 3B4 3B6	K067 10 060 0	EINSATZ INSERT	1J5
K037 00 020 0	DRUCKFEDER	3B4	K067 10 061 0	SCHEIBE DISC	1J5
K037 00 021 0	SCHEIBE	3B2 3B4	K067 13 014 0	FEDERSCHEIBE SPRING DISC	3A10
K037 00 022 0	HUELSE	3B4	K067 16 001 3	EXZENTER ECCENTRIC	1L5
K037 00 092 3	ANSCHLAGNOCKEN CAM	5E2 5F3	K067 16 053 3	KURBEL CRANK	3G2
K037 00 093 0	STELLKLOBEN BLOCK	5E2	K067 16 060 0	GLEITSTEIN SLIDE STONE SINT C 51	3G1
K037 00 095 0	KLOBEN BLOCK	5E2	K067 31 002 3	EXZENTER 8MM	3K3
K037 00 112 0	WELLE SHAFT	5F3	K067 31 201 3	HEBEL LEVER	3H1
K037 00 193 0	MUTTER NUT	3C10	K067 31 203 0	ZUGSTANGE PULL ROD	3K1
K049 00 031 0	LAGER BEARING	5F1	K067 31 205 0	WELLE SHAFT	3H2
K053 00 035 0	SCHEIBE DISC	4H8	K067 31 207 0	BOLZEN BOLT	3K4
K061 00 105 0	STEGSCHEIBE DISC	1D8 1D11	K067 31 217 0	HALTER HOLDER	3A6
K061 00 241 0	LUEFTERHEBEL	3E1 3E3 3E5	K067 31 217 4	HALTER HOLDER	3B5
K067 00 018 0	GLEITHUELSE SLIDE BUSH D=6,35	1L2	K067 31 221 3	FUSSSTANGE FOOT BAR	3L1
K067 00 042 3	KLOBEN BLOCK	2J1 2J3	K067 31 221 4	FUSSSTANGE FOOT BAR	3L1
K067 00 177 0	DRUCKFEDER PRESSURE SPRING	4K11 4M11	K067 31 224 0	BUCHSE BUSHING	3H2
K067 00 232 0	SPEZIALBOLZEN BOLT	3H10	K067 31 225 0	BUCHSE BUSHING	3H3
K067 00 233 0	FEDERSCHEIBE SPRING DISC	3H10	K067 32 015 0	DRUCKFEDER PRESSURE SPRING	2C6
K067 00 238 0	EXZ.-GLEITRING	3J8	K068 00 012 0	ARMDECKEL ARM COVER HI	1C3
K067 00 241 0	KLAMMER CLAMP	3J3	K068 00 017 0	BOLZEN BOLT	1J2
K067 00 246 0	ZUGFEDER SPRING	3L10	K068 00 018 0	GLEITHUELSE	1L2
K067 00 247 0	HAKEN HOOK	3M10	K068 00 021 3	DECKSCHEIBE COVER DISC	1E8
K067 00 312 3	ZUGSTANGE PULL ROD	3K3	K068 00 028 0	FADENANZUGFEDER TENSION SPRING	1E6
K067 00 313 3	KULISSENHEBEL CRANK LEVER	3H4	K068 00 029 0	AUFLAGE SUPPORT	1D3
K067 00 329 3	KLOBEN BLOCK	3B6	K068 00 030 0	BOLZEN BOLT	1E6
K067 00 332 0	GLEITSTUECK SLIDE PIECE	3B5			

Teile-Nr.	Benennung	Bildtafel	Teile-Nr.	Benennung	Bildtafel
K068 00 034 0	FADENOESE THREAD LOOP	1D1	K069 25 001 0	HAUBE COVER	5A4
K068 00 043 0	GELENK JOINT	2H1 2H3	G-4		
K068 00 044 0	GELENKBOLZEN JOINT BOLT	1K4	K069 31 203 0	BOLZEN BOLT	3L1
K068 00 046 0	NADELSTG.SCHW.	2J1	K069 31 204 0	GELENK JOINT	3K1
K068 00 047 0	BOLZEN BOLT	2H1 2H3	K069 31 205 3	WINKELHEBEL LEVER	3K1
K068 00 066 0	DRUCKFEDER PRESSURE SPRING	3C2 3C4 3D6	K069 31 207 0	NADELSTGSCHWINGE OSCILLATOR	2J3
K068 00 068 0	FUEHRUNG GUIDE	3B2 3C4 3C6	K077 11 022 0	AUFLAGE SUPPORT	5L3
K068 00 174 3	STELLRING ADJ RING	4G9	K077 11 023 0	ZENTRIERSTUECK CENTERING PIECE	5K4
K068 00 192 0	OELFILZ OIL FELT	4D2	K081 00 166 0	MAULSCHLUESSEL WRENCH	5H1
K068 00 238 0	BOLZEN BOLT	3K9	K081 00 179 0	DRUCKSTANGE PRESSURE ROD	5F5
K068 00 240 0	GELENK JOINT	3L10	K088 12 738 0	DISTANZSCHEIBE DISTANCE DISC	4H8
K068 00 332 0	BOLZEN BOLT	3D5 3E1 3E3	K095 00 011 0	OELFILZ OIL FELT	3J3
K068 00 490 0	BOLZEN BOLT	1D10	K098 00 016 0	FADENHEBEL	1K2
K068 00 491 0	FADENANZUGFEDER TENSION SPRING	1D10	K098 00 068 3	STOFFSTG.KLOBEN	3B1 3B3
K068 00 842 0	OBERTEILSTUETZE SUPPORT HOLZ	5B5	K098 10 100 0	OELFILZ OIL FELT	1K5
K068 10 035 0	OELROHR OIL PIPE	1E3	K099 00 233 0	BOLZEN BOLT	3G1
K068 10 214 0	KLASSENSCHILD NUMBER PLATE		K099 00 480 0	SPANNUNGSFEDER TENSION SPRING	1D8 1E11
K068 10 214 2	KLASSENSCHILD NUMBER PLATE		K099 00 481 0	STIFT PIN 1,8M6X9J14	1C8 1D11
K069 00 165 0	HAKEN HOOK	1G4	K099 00 483 0	DRUCKFEDER PRESSURE SPRING 0,45 C DIN 2076 C	1C5 1D9
K069 00 308 4	KETTE CHAIN	3D11	K099 00 489 3	DECKSCHEIBE COVER DISC	1E10
K069 13 002 0	FRUCKFEDER	3B2	K167 00 067 0	HUELSE BUSH	3E10 3G10
K069 14 025 0	STAENDER STAND	1G3	K167 00 178 0	SPULENGEH.OBERT	4B3
K069 14 028 0	SCHARNIER HINGE	1F3	K167 00 178 2	SPULENGEH.OBERT	
K069 24 132 0	LINEAL GUIDE	5J8	K167 00 178 4	SPULENGEHAEUSE BOBBIN CASE	4A3 4B1
K069 24 133 0	SCHRAUBE SCREW	5H8	K167 00 179 4	SPULENGEHAEUSE BOBBIN CASE	4C1 4C3
K069 24 134 0	FEDER SPRING	5H8	K167 00 180 0	SPULE BOBBIN	4C2 5D1
K069 24 136 0	FUEHRUNGSBLECH GUIDE PLATE	5J8	K169 00 019 0	OELFILZ OIL FELT 30X8,5X2	4E8 4E11 4J1
K069 24 137 3	ANSCHLAG GUIDE	5H8	K169 00 020 0	KLAMMER CLAMP	4E8 4E11
K069 24 139 0	SCHRAUBE SCREW	5H8	K169 00 064 0	LUEFTERHEBEL LIFTER LEVER 13MM	3D5

Teile-Nr.	Benennung	Bildtafel	Teile-Nr.	Benennung	Bildtafel
K169 00 153 0	ARRETIERSTUECK CLAMP	1E3	K169 15 028 0	GREIFERWELLE HOOK SHAFT	4L7
K169 00 154 3	GREIFERBOCK HOOK SUPPORT	4E2	K169 15 029 3	KEGELRAD BEVEL GEAR	4L7
K169 00 154 4	GREIFERBOCK KPL HOOK SUPP CPL	4F3	K169 15 030 0	GREIFERWELLE	4L6
K169 00 160 0	LAGER BEARING	4F8 4F11	K169 15 031 0	GREIFERW.LAGER	4J1
K169 00 162 0	BLATTFEDER LEAF SPRING	1F1	K169 15 032 0	BUCHSE BUSHING	4K8
K169 00 181 4	GREIFER HOOK	4D1 4D2	K169 15 033 0	BUCHSE BUSHING	4K10
K169 00 184 3	KEGELRAD BEVEL GEAR	4F2	K169 16 020 3	HUBEXZENTER STROKECAM	4F8
K169 00 191 0	DECKRING COVER RING	4B3	K169 16 022 0	GELENK JOINT	4M9
K169 00 194 0	BLECH PLATE	4D3	K169 16 023 3	WINKELHEBEL LEVER	4G11
K169 00 196 3	KEGELRAD	4L6 4M4	K169 16 024 3	UMLENKSTIFT PIN	4L8
K169 00 211 0	KUPPLUNGSSTUECK COUPLING PIECE	4L12	K169 16 025 0	BUCHSE BUSHING	4H12
K169 00 212 0	SCHEIBE DISC	4M10	K169 25 001 4	HOLZANSCH.TISCH	5K9
K169 00 213 0	ZAHNRIEMEN BELT 14V 620/ 6	1M6 4M11	K169 25 002 4	HOLZANSCH.TISCH	5L9
K169 00 215 0	HUELSE BUSH	4L11	K169 25 003 0	DRUECKERFUSS	5K9
K169 00 215 4	KUPPLUNG COUPLER	4K11	K169 25 004 0	ABDECKBLECH	5L9
K169 00 217 0	GABEL FORK	4E9 4E12 4H2	K267 10 001 0	ARM ARM	1B3
K169 00 218 0	WINKEL ANGLE	4D8 4D12 4G2	K267 10 003 0	ARM	1A3 1B3
K169 00 220 0	KLEMMLEISTE CLAMP RAIL	4D8 4D12 4G2	K267 10 023 0	BOLZEN BOLT	5F4
K169 00 221 0	EXZENTER ECCENTRIC	4E5 4E8 4E11 4H1	K267 10 024 0	BUCHSE BUSHING	5D4
K169 00 229 0	DRUCKFEDER PRESSURE SPRING	4E5 4E11 4H2	K267 10 025 4	HANDRAD K 80 D	2C9
K169 00 230 3	EXENTER	4F12 4J2	K267 10 026 4	HANDRAD K 95 D	2C9
K169 00 234 3	GABEL FORK	3K9	K267 11 001 0	FADENHEBEL THREADLEVER D=6,35	1J2
K169 00 241 0	ZUGSTANGE PULL ROD	3G2	K267 11 003 0	FADENHEBEL THREADLEVER D=6,35	1J2
K169 00 344 0	GABEL FORK	4E5	K267 13 006 0	ZUGSTANGE PULL ROD	3B11
K169 14 006 0	ARM ARM	1A4 1B4	K267 13 006 4	ZUGST OBERTEIL ROD UPPER PART	3B11
K169 14 007 0	UNTERARM	1B4	K267 31 001 3	EXZENTER ECCENTRIC 10MM	3L3
K169 15 001 3	GLEITSTUECK SLIDE PIECE	4E3	K268 10 004 0	KOPFDECKEL HEAD COVER	1C1 1D1
K169 15 003 3	ZAHNRIEMENRAD BELT PULLEY	1M6	K268 10 006 0	BUCHSE BUSHING	1M5
K169 15 004 0	LAGER BEARING	4E5	K268 10 007 0	BUCHSE BUSHING	1K5
K169 15 027 3	STELLRING ADJ RING	4K8	K268 10 012 0	ARMDECKEL ARM COVER	2C2
			K268 10 013 3	LAGERHUELSE BEARING BUSH HI.	1M7

Teile-Nr.	Benennung	Bildtafel	Teile-Nr.	Benennung	Bildtafel
K268 10 013 4	LAGERHUELSE HI.	1M7	K268 16 001 3	STICHST HEBEL LEVER	3K10
K268 10 016 0	BOCK SUPPORT	3F10 3H10	K268 16 002 0	BOLZEN BOLT	3K10
K268 10 019 3	HANDRAD HANDWHEEL	2C10	K268 16 003 0	LASCHE SHACKLE	3L10
K268 10 039 3	HUELSE BUSH	1J5	K268 16 004 0	DRUCKSTUECK PRESSURE PIECE	3K12
K268 10 040 3	STOPFEN PLUG	1J5	K268 16 005 0	BLATTFEDER LEAF SPRING	3K12
K268 10 041 0	FADENHEB SCHUTZ PROTECTOR	1C1	K268 16 006 0	STANGE ROD	3K12
K268 10 049 0	TRICHTER FUNNEL	2A3	K268 16 007 3	GRIFF GRIP	3K12
K268 10 049 4	OELER LUBRICATOR	2A3	K268 16 008 0	ANSCHLAGSTUECK GUIDE PIECE	3K11
K268 11 001 0	TRAEGER CARRIER	1C7 1D11	K268 16 014 0	DRUCKFEDER PRESSURE SPRING	3K12
K268 11 001 4	TRAEGER CARRIER	1C11	K268 16 015 0	ANSCHLAG GUIDE	3L11
K268 11 002 4	1-NADEL CARRIER	1C7	K268 16 023 0	DAEMPfung ABSORBER	3K10
K268 11 003 0	OESE EYELET	1B6 1C10	K268 16 025 4	STICHST KLOBEN LEVER BLOCK	3H12
K268 11 004 0	FADENFUEHRUNG THREAD GUIDE	1B1	K268 17 001 3	MITNAHMERING RING	1M5
K268 11 005 0	BOLZEN BOLT	1C8 1D11	K268 17 003 0	ARM ARM	2B7
K268 11 006 0	AUSLOESEBLECH RELEASE PLATE	1C5 1C10	K268 17 005 0	DECKEL COVER	2C6
K268 11 007 0	AUSLOESESTIFT RELEASE PIN	1D8	K268 17 005 4	SPULER BOBBIN WINDER	2C6
K268 11 008 3	AUSLOESESTIFT RELEASE PIN	3D2 3D4 3D6	K268 17 006 3	SPULERBOCK WINDER BLOCK	2C8
K268 11 022 3	WINKEL ANGLE	3D2 3D4 3D6	K268 17 007 4	SPULERWELLE WINDER SHAFT	2C8
K268 11 024 0	SCHEIBE DISC	1C6 1C10	K268 17 008 0	MESSER KNIFE	2B8
K268 12 003 0	FUEHRUNGSWINKEL GUIDE ANGLE	2K1 2K3	K268 17 010 3	AUSLOESEHEBEL RELEASE LEVER	2C8
K268 13 001 3	HEBEL LEVER	3C10	K268 17 011 0	BUNDBUCHSE	2C8
K268 13 003 0	BOLZEN BOLT	3B10	K268 23 001 4	NADELSTANGE NEEDLE BAR	2M1 2L3
K268 13 007 0	BLATTFEDER LEAF SPRING	3F11 3H11	K268 31 001 3	OELROHR OIL PIPE	3H4
K268 13 008 0	BOLZEN BOLT	3F11 3H11	K268 31 006 3	WELLE SHAFT	3F1
K268 13 012 0	HUELSE BUSH	3A6 3B3	K268 31 008 0	BUCHSE BUSHING	3F2
			K268 35 016 3	HALTER HOLDER	5C2
			K269 10 002 4	OBERTEIL K	1A3
			K269 10 003 4	OBERTEIL	1B3
			K269 10 004 4	OBERTEIL HEAD	1B3
			K269 10 005 4	OBERTEIL K	1B3

Teile-Nr.	Benennung	Bildtafel	Teile-Nr.	Benennung	Bildtafel
K269 10 009 0	RIEMENSCHUTZ BELT GUARD VO.	5C5	K381 11 004 3	RAENDELMUTTER KNURLED NUT	1A8 1E11
K269 10 010 0	RIEMENSCHUTZ BELT GUARD HI.	5C5	K396 11 002 0	FADENLEITSTIFT GUIDE PIN	1B8 1C12 2B3
K269 10 012 0	BOLZEN BOLT	5F4	K396 11 026 0	SPANNBUCHSE TENSION BUSHING	2A4
K269 13 002 0	DREHFEDER SPRING	3B10	K396 11 031 0	BUCHSE BUSHING	1A8 1C12 2A4
K269 13 003 4	ZUGSTANGE PULL ROD	3C11	K396 11 047 0	DRUCKFEDER PRESSURE SPRING	1B8 1C12 2A4
K269 15 001 0	LUEFTERHEBEL LIFTER LEVER	4D2	K396 13 001 3	KNIEPLATTE	5G3
K269 16 001 0	HEBEL LEVER VO.	4D7 4D10 4G3	K396 17 006 0	HUELSE BUSH	2B7
K269 16 002 3	HEBEL LEVER HI.	4D7 4D10 4G3	K396 17 008 0	DRUCKFEDER PRESSURE SPRING DRAHT 0,6	2B7
K269 16 003 0	BOLZEN BOLT	4H8	K396 17 015 4	SPANNUNG TENSION	1A6 1A8 1B12 2B4
K269 16 004 0	LAGERBOLZEN BEARING BOLT	4E6 4E9 4H2	K396 17 016 0	FADENFUEHRUNG THREAD GUIDE	1A8 1B11 2B4
K269 16 005 0	WELLE SHAFT	4G8	K396 17 017 0	GEWINDEBOLZEN THREADED BOLT	1A7 1B12 2B4
K269 16 006 0	VORSCHUBWELLE	4J8	K396 17 027 0	KLOBEN BLOCK	2B7
K269 16 008 4	STICHSTELLER	3K9	K396 17 028 3	NOCKEN CAM	2B7
K269 16 009 4	VORSCHUBGABEL	4E10 4H3	K467 11 022 0	SPANNSCHEIBE TENSION WASHER	1D8 1D11
K269 16 010 4	VORSCHUBGABEL	4E7	K699 99 158 7	OELDOCHT	2A3
K296 16 067 0	BUCHSE BUSHING	1D6 1D9	K893 03 765 6	SENKSCRAUBE SCREW M4X8	2C8
K367 11 012 0	BOLZEN BOLT	1D8	K893 06 714 7	SCHRAUBE SCREW M4X6	1D3
K367 11 014 0	SCHEIBE DISC DELRIN	1D8	K893 06 734 7	ZYL.SCHR. M5 X 6	2L1
K367 11 023 0	UMLENKSTIFT PIN	1C7 1D11	K893 23 049 8	FEDERSCHEIBE SPRING DISC A8	3A10
K367 11 024 0	DRUCKKNOPF PUSHBUTTON	1C8	K893 33 103 0	GEWINDESTIFT THREADED PIN M6X6	4L8
K367 11 034 0	ROLLE ROLLER	1E6 1E9	K893 96 146 0	SCHRAUBE SCREW M4X25	1E3
K367 11 035 0	ZWISCHENSCHIEBE WASHER	1E6 1E9	K894 45 037 8	FAECHERSCHIEBE A5,3	2A9
K367 11 036 0	FUEHRGS SCHEIBE GUIDE DISC	1E6 1E9	K973 43 133 0	DRUCKFEDER PRESSURE SPRING	1B8 1C12 2A4
K367 11 051 0	KLEMMPLATTE CLAMPING PLATE	1B5 1C9	K990 24 018 1	VERSCHL STOPFEN PLUG 9,5X9/7,5	1M3
K367 11 056 0	DREHFEDER SPRING	1C8 1C11	K990 42 005 5	DOCHT WICK 12-FAEDIG	1L2 1M4
K367 16 064 0	STOPFEN PLUG	2A3			
K367 17 004 0	KLEMMFEDER CLAMPING SPRING	2C8			
K367 17 008 3	SPULERRAD WINDER WHEEL	2A6			

Teile-Nr.	Benennung	Bildtafel	Teile-Nr.	Benennung	Bildtafel
K990 81 001 9	OELER	5L1	K992 01 215 7	SCHEIBE	3H4
	LUBRICATOR			DISC	
	LEER MOD250			6,1	
K990 81 003 8	KASTEN	5L1	K992 01 243 0	GEWINDESTIFT	4M7
	BOX			THREADED PIN	
K990 81 006 1	SCHRAUBENDREHER	5J1		NR.18X 7,5	
	SCREWDRIIVER		K992 01 443 0	GEWINDESTIFT	3L3
	A 0,4X 2,5			NR.14X6,5X7	
K990 81 006 2	SCHRAUBENDREHER	5J1	K992 01 461 0	GEWINDESTIFT	4F8
	SCREWDRIIVER			THREADED PIN	
	A 0,8X 5,5			NR.28X 3,5	
K992 00 053 0	SCHRAUBE	4E5 4E8	K992 01 480 0	GEWINDESTIFT	1K6
	SCREW	4E11 4H1		THREADED PIN	
	NR.40X7			NR.18X 4	
K992 00 074 7	SCHRAUBE	4E11	K992 01 495 0	GEWINDESTIFT	1K4 3B6 3C1
	SCREW			THREADED PIN	3C3 4M4 4M6
	NR.88X1,5			NR.18X 6	
K992 00 090 0	SCHRAUBE	4L7	K992 01 658 0	SCHRAUBE	4B3
	SCREW			SCREW	
	NR.18X 10			M2X5,0	
K992 00 181 0	SENKSCHRAUBE	1G4	K992 01 756 7	MUTTER	1E8 1E11
	SCREW			NUT	
	NR.28X5,47			NR.18	
K992 00 266 7	SENKSCHRAUBE	4D3	K992 01 914 8	SENKSCHRAUBE	4B3
	SCREW			SCREW	
	NR.50X 4,			NR.9X1,	
K992 00 328 0	SCHRAUBE	2J1 2J3	K992 01 915 7	LINSENSCHRAUBE	4B3
	SCREW			SCREW	
	NR.40X9X7			NR.9X2,5	
K992 00 386 7	MUTTER	3C11	K992 01 951 0	SENKSCHRAUBE	4C2
	NUT			SCREW	
	NR.30			NR.40X27	
K992 00 388 7	SCHRAUBE	1E1	K992 01 995 0	GEW.STIFT	4L6 4M4
	SCREW			NR.18X6	
	NR.40X8,		K992 02 367 7	SCHRAUBE	1E3 1F1
K992 00 447 7	MUTTER	3J9		SCREW	
	NUT			M4X4,3	
	NR.23 3,8		K992 02 399 7	SCHRAUBE	2C10 2C11
K992 00 566 0	SCHRAUBE	3K12		SCREW	
	SCREW			NR.24X14 LONGLOK	
	NR.28X11,		K992 02 400 0	GEWINDESTIFT	4H10
K992 00 680 0	ROLLE	3C6		THREADED PIN	
	ROLLER			M5X4	
K992 00 686 0	SCHRAUBE	4E2	K992 02 403 0	SCHRAUBE	5C1
	SCREW			SCREW	
	NR.40X10X8			M3X3	
K992 00 687 7	SCHRAUBE	3M1	K992 02 407 7	SCHRAUBE	1C6 1C9
	SCREW			SCREW	
	NR.32X6			M3X2,3	
K992 00 720 0	GEW.STIFT	4F12 4J2	K992 02 436 0	GEWINDESTIFT	4J8
K992 00 721 7	SCHRAUBE	2L3 2M1		THREADED PIN	
	SCREW		K992 02 465 6	SCHRAUBE	1D1 1E1
	NR.88X3X1			SCREW	
K992 00 959 7	FL.KOPFSCHR.	4E5 4E8 4H1		M4X6	
	NR. 88X1,7		K992 02 475 0	ZYL.SCHR.	4D7 4D10 4G3
K992 00 978 7	SCHRAUBE	3E1 3E3 3E6		M5X14	
	SCREW		K993 03 095 7	SENKSCHRAUBE	1B1
	NR.86X9,			SCREW	

Teile-Nr.	Benennung	Bildtafel	Teile-Nr.	Benennung	Bildtafel
K993 03 135 7	M3X8 SENKSCHRAUBE SCREW	2D6	K993 34 059 7	MUTTER NUT M8	3J10
K993 06 096 7	M4X8 SCHRAUBE SCREW	2D8	K993 43 121 7	SCHRAUBE SCREW M8X16	5E2
K993 06 134 7	M3X10 SCHRAUBE SCREW	2B8	K993 52 076 7	GEWINDESTIFT THREADED PIN M3X8	4D8 4D11 4G1
K993 06 135 7	M4X6 SCHRAUBE SCREW	1B3 1B6 1C10	K993 52 096 0	GEW.STIFT M4X8	1C7
K993 06 177 7	M4X8 SCHRAUBE SCREW	5E6	K993 52 119 0	GEW.STIFT M6X16	3J12
K993 06 673 7	M6X12 SCHRAUBE SCREW	4L10	K993 52 119 7	GEWINDESTIFT THREADED PIN M6X16	4K11 4M11
K993 06 715 7	M3X5 SCHRAUBE SCREW	1D1	K993 53 105 7	GEWINDESTIFT THREADED PIN M5X8	4H10
K993 06 737 7	M4X8 SCHRAUBE SCREW	1D1	K993 67 163 4	RAENDELSCHRAUBE KNURLED SCREW M6X28	3E11 3G11
K993 06 759 7	M5X12 SCHRAUBE SCREW	5C4	K993 67 163 7	RAENDELSCHRAUBE KNURLED SCREW M6X28	3E11 3G11
K993 16 135 0	M6X18 SCHRAUBE SCREW	5C4	K993 90 400 8	SCHRAUBENDREHER SCREWDRIVER F.I.6KT.SW 1,5 X40	5H1
K993 19 036 7	SENKHOLZSCHR. 4,5X20	5E1	K993 91 081 7	SCHRAUBE SCREW M4X8	1B1
K993 19 037 7	SCHRAUBE SCREW	1D1	K993 91 084 7	SCHRAUBE SCREW M4X16	2K1 2K3
K993 19 038 7	SCHRAUBE SCREW	5C4	K993 91 103 8	ZYL.SCHR. M5X12	3A6 3B2 3B4 3C6
K993 19 040 7	SCHRAUBE SCREW	1D1	K993 91 104 8	ZYL.SCHR. M5X16	2A9
K993 19 046 7	SCHRAUBE SCREW	5L5 5L6	K993 91 123 7	SCHRAUBE SCREW M6X12	3F10 3H1 3H4 3H10 3H12 4L12
K993 26 128 7	FLUEGELSCHEIBE FLY SCREW M8X20	1G4	K993 91 123 8	SCHRAUBE SCREW M6X12	3K12
K993 33 081 0	GEWINDESTIFT THREADED PIN M4X4	3J12	K993 91 124 8	SCHRAUBE SCREW M6X16	3G2
K993 34 056 7	MUTTER NUT M4	2C4	K993 91 146 7	SCHRAUBE SCREW M8X20	1F3
K993 34 057 7	MUTTER NUT M5	1A5 1A7 1B10 2C2	K993 91 180 8	ZYL.SCHR. M10X35	1E4
			K993 92 069 8	GEWINDESTIFT THREADED PIN M3X3	2L3 2M1
			K993 92 099 8	GEW.STIFT M5X6 45H SCHWARZ	2A6

Teile-Nr.	Benennung	Bildtafel	Teile-Nr.	Benennung	Bildtafel
K993 92 109 8	GEW.STIFT M6X6	3D6 3E1 3E3 3L3	K994 80 146 7	SCHEIBE DISC B6,4	5B3 5E6
K993 92 110 8	GEW.STIFT M6X8	1J3 1K8 2H1 2H3	K995 14 021 7	RAENDELMUTTER KNURLED NUT M6	3E11 3G11
K993 92 111 8	GEW.STIFT M6X10	1K6 1L5 1M5 2A9 2A10	K995 14 035 0	MUTTER NUT M5 /PA	1B8 1C12 2A4
K993 93 110 8	GEWINDESTIFT THREADED PIN M6X8	1M8	K995 34 061 7	MUTTER NUT PG11X9	5L5 5L6
K993 93 112 8	GEWINDESTIFT THREADED PIN M6X12	1M6 2C9 2C10	K996 01 096 8	SICHERGS RING CIRCLIP 20X1,2	1K7
K993 95 092 8	GEW.STIFT M5X6	2B7	K996 01 105 8	SICHERGS RING CIRCLIP 32X1,5	3J8
K993 96 141 0	SCHRAUBE SCREW M4X12	4F5 4F8 4F11	K996 06 025 0	KUGEL BALL 6,350	4L11
K993 96 158 7	SCHRAUBE SCREW M5X6	4H10	K996 07 006 8	SICHERGSSCHEIBE SAFETY DISC 3,2	2C6
K993 97 098 7	SCHRAUBE SCREW M4X8	1B5 1D12 2B1 2C4	K996 07 007 8	SICHERGSSCHEIBE SAFETY DISC 4	3L1
K993 99 189 7	SCHRAUBE SCREW M6X5	3B10	K996 07 008 8	SICHERGSSCHEIBE SAFETY DISC 5	5J9
K994 05 034 7	MUTTER NUT M3	4D8 4D11 4G1	K996 07 009 8	SICHERGSSCHEIBE SAFETY DISC 6	3J1 3K3
K994 05 038 7	MUTTER NUT M6	3J4	K996 07 011 8	SICHERGSSCHEIBE SAFETY DISC 8	3E2 4G10 4H12 4K10 4M9
K994 27 074 0	KERBSTIFT DOWEL PIN 3X18	5F5	K996 07 012 8	SICHERGSSCHEIBE SAFETY DISC 9	3C6
K994 27 095 0	KERBSTIFT DOWEL PIN 4X20	3F1	K996 08 699 0	KUGELLAGER BALLBEARING 6204.2ZRN	1M7
K994 27 136 0	KERBSTIFT DOWEL PIN 6X22	1M4	K996 10 106 8	SPRENGRING SPRING RING SP47	1M7
K994 38 109 8	SPANNHUELSE CLAMPING SLEEVE 5X20	3H12	K996 13 136 0	KUGELKNOPF SPHERIC BUTTON C 25 M 6	3L12
K994 46 102 7	SCHRAUBE SCREW M5X16	3B5	K998 82 024 8	GREIFRING RING G 3,5X0,6	3D2 3D4 3D6
K994 46 110 7	SCHRAUBE SCREW M6X10	3J10	K998 86 159 0	O-RING RING 19X4	2A6 5D1
K994 46 111 7	SCHRAUBE SCREW M6X12	4E3	K999 19 022 9	VERSCHL STOPFEN PLUG NR 211/7	1F3
K994 46 112 7	SCHRAUBE SCREW M6X16	3M11			

Teile-Nr.	Benennung	Bildtafel	Teile-Nr.	Benennung	Bildtafel
K999 23 034 0	NADELKAEFIG NEEDLE CAGE K12X15X9	4E3 4F2			
0791 00 108 1	GARNST ROHR YARN SUPP TUBE LANG	5K6			
0791 00 108 4	GARNST.ROHR KPL	5M6			
0791 00 108 5	GARNST.ROHR KURZ UNTEN	5K5			
0791 00 108 6	GARNST.ROHR	5J5			
0791 00 108 8	GARNST.ROHR KPL	5M5			
0791 00 109 0	GARNHALTER KPL	5L4			
0791 00 109 1	GARNHALTER KPL YARNHOLDER CPL	5K3			
0791 00 109 3	SCHEIBE	5J3 5K3			
0791 00 109 4	LINSENK.ZYL.SCHR.	5J3 5L3			
0791 00 109 5	MUTTER	5J3 5K4 5K5			
0791 00 109 6	FADENFUEHRG KPL THREADGUIDE CPL	5J4			
0791 26 963 1	B ANL 269 INSTR. 269 269 D/GB/F/E/I				
0798 44 651 1	SCHILD PLATE D725/DE				

Teilenummern neu hinzu: 03/00

0APP	001132	Haltestück	9G8	0269	130013	Hebel	8C10, 9B7
MG41	004073	Spanpl. Schr.	9L7, 9L9	0269	130034 M	Zugst. Unterteil V	3C11
MG53	007921	Winkel	8H7, 9B2	0269	160084	Stichsteller K	3K9
MG53	007922	Lasche	8H7, 9B2	0269	160094	Vorschubgabel K	4E10, 4H3
N800	005413	Lineal-Körper	5J8	0269	160104	Vorschubgabel K	4E7
N800	005417	Schraube	5H8	0269	160110	Verstellexzenter	4E5, 4E6, 4H11
N800	015412	Rollenlineal	5J9	0269	160130	Anschlagstück	3K11
0002	007504	9500 Wippschalter	9F7	0269	360014	Obert. Satz K	8E10
0037	001280	Fadensp. Scheibe	1B8, 1C12, 2A4	0269	367529	Pn. Fußlüft. K	9E8
0067	000423	Nadelstang. Kloben	2J5	0269	367819	Pn. Verriegelung K	8F12
0067	003123	Zugstange K	3K3	0291	000159	Fadenfuehrung	2M3, 2M5
0067	100014	Armwelle K	1M3	0296	360024	Gestellsatz K	9A6
0067	312174	Gleitst. Halter K	3B6	0367	360133	Magnetleitung	9D6
0068	000430	Nadelstang. Gelenk	2H5	0367	367704	Anschlußteile K	9C4
0068	000470	Bolzen	2H5	0396	350650	Tragplatte	8C8
0069	312070	Nadelstg. Schwinge	2J5	0550	510430	Winkel	8J2
0069	360040	Winkel	8E10, 9D7	0742	002096	Ideal-Schelle	9K1
0104	250010	Haube	5G4	0744	001793 A	Kuppl. Dose	9L1
0167	001870	Spulengeh. Oberteil	4B3	0744	001793 B	Kuppl. Stecker	9L1
0169	001544	Greiferlager K	4F3	0744	001796	Schlauchtülle	9J1, 9L1
0169	150364	Kegelradpaar K	4J4, 4J6	0797	003031	Druckleitung K	9L5
0169	150384	Kegelradpaar K	4K7	0798	120401	Cord-Clip	9F9
0221	110150	Scheibe	1B8, 1C12	0798	500088	Trafo, Nählicht	9M8
0221	110154	Vorspannung K	1A6, 1A8, 1B12	0894	450368	Fächerscheibe	8D8
0221	110160	Buchse	1B8, 1C12, 2A4	0894	450418	Fächerscheibe	9G8
0241	001067	Fadenführung	1D1	0907	487519	Anbausatz K	9J7
0267	120030	Führ. Winkel	2K3, 2K5	0971	411810	Zwischenblech	8K2
0267	130064	Zugst. Obert. K	3B11	0992	003280	Li. Zyl. Schr.	2J5
B267	310203	Kulissenhebel K	8J4	0992	007200	Gew. Stift	4J2
0267	310210	Winkel	8K5	0992	019550	Gew. Stift	4M4, 4M6
0267	310220	Bolzen	8H4	0993	190367	Scheibe	2K5
0267	310230	Paszschraube	8K4	0993	270940	Gew. Stift	8B2
0267	367529	Pn. Hubverst. K	8M12	0993	411208	Rändelmutter	2A4, 1B8, 1C12
0268	100134	Lagerhülse K Hi.	1M7	0993	531050	Gew. Stift	4H10
0268	100393	Hülse K	1J5	0993	910847	Zyl. Schr.	2K5
0268	100403	Dichtstopfen K	1J5	0993	921108	Gew. Stift	2H5
0268	100450	Armdeckel	8B4	0993	931108	Gew. Stift	1M6
0268	110014	Fadensp. Träg. K	1C11	0994	050377	6kt. Mutter	3C12
0268	110024	Fadensp. Träg. K	1C7	0996	070078	Sich. Scheibe	8H5
0268	120030	Führ. Winkel	2K5	0998	220597	Befestigung L	9D7
0268	130140	Verb. Mutter	3C10	0998	881040	Paszscheibe	2B7
0268	160073	Griff K	3L12	0999	220512	Ventil	8J10
0268	160180	Griff	8E3	0999	220596	Befestigung F	8C10, 9B8
0268	160240	Griffstange	8E2	0999	220597	Befestigung L	8D10
0268	230010	Nadelstange	2L3, 2L5	0999	220627	Zylinder, doppel	8C10, 9C7
0268	230014	Nadelstange	2L5	0999	220705	Anschlußplatte	9C5
0268	310063	Nadeltr. Welle K	3F2	0999	220706	Anschlußplatte	8C5
0268	350163	Posi. Halter	9G11	0999	220757	Zylinder, einf.	8D3
0268	350404	Leitung K	8B7	0999	220779	Zylinder, doppelt	8H5
0268	350414	Tragplatte K	8C7	0999	240302	Doppelnippel	8C5, 8C8 8D8, 8J7, 8J10, 9B5
0268	360030	Führ. Buchse	8B3	0999	240303	Doppelnippel	9B2
0268	360040	Rändelkopf	8B3	0999	240305	Vert. Block	8G10
0268	360050	Gabel	8C2	0999	240341	Schottverschr.	8D6, 9C4, 8J9
0268	360060	Stellschr.	8C2	0999	240385	Wi-E-Verschr.	8C7
0268	360070	Gew. Bolzen	8E2	0999	240387	T-Es-Verschr.	8G10
0268	360080	Kloben	8E3	0999	240392	Wi.-E-Verschr.	9A4
0268	360090	Klemmkloben	8D2	9041	100050	Oeldocht, rund	2A3
0268	360104	Klemmkloben	8D2	9041	100212	Baumwolldocht	1L2, 1M3
0268	360110	Haken	8E3	9081	100251	Schr. Dreher gerade	5H2
0269	120010	Schwinge	2J5	9081	500010	Schraubendreher	5J2
				9081	500051	Schraubendreher	5J2

9201	112897	6kt. Schr.	8K1	9234	000087	6kt. Mutter	5B3, 2C4, 2K3, 2K5
9202	002057	Zyl. Schr.	8C4	9301	102203	RGKPF. Zyl. Stift	8C3
9202	002067	Zyl. Schr.	1B1	9305	603270	Spannstift	3H12
9202	002068	Zyl. Schr.	8D3	9330	000087	Scheibe	1E1
9202	002097	Zyl. Schr.	2K3, 2K5	9330	000097	Scheibe	3B6, 8H4, 8J1
9202	002488	Zyl. Schr.	3A6, 3C6	9330	000107	Scheibe	3M10, 8K1, 8K5 8D10, 9D7
9202	002498	Zyl. Schr.	2A9	9330	900117	Scheibe	5E6, 8E8
9202	002887	Zyl. Schr.	4L12, 3H10, 3H12, 3F10 3H1, 3H4, 8D10	9330	900127	Scheibe	1F3
9202	002888	Zyl. Schr.	3K12	9330	000167	Scheibe	8J7, 8H9, 9A4, 9B2
9202	002897	Zyl. Schr.	8J7, 9D7	9330	000177	Scheibe	5L5, 5L6
9202	002927	Zyl. Schr.	9A4, 9C4	9332	500150	Federscheibe	3A1, 8B3
9202	002937	Zyl. Schr.	8J9	9352	000200	Sich. Ring	1K6
9202	003307	Zyl. Schr.	1F3	9710	001030	Ventil, Pedal	8K1
9202	003317	Zyl. Schr.	9G8	9710	061110	Ventil, Magnet	8C5, 9B5
9202	003738	Zyl. Schr.	1E4	9710	920120	Ventil	8D9
9202	022877	Zyl. Schr.	9C7	9710	981010	Schalldämpfer	9B5
9202	022937	Zyl. Schr.	8H9	9710	982005	Schalldämpfer	8J10
9202	042497	Zyl. Schr.	3B6	9731	002001	Schlauch	9K1
9202	042887	Zyl. Schr.	3J11, 3H1, 3H4, 4E3	9731	005004	Schlauch	8D9, 8D10, 8F2, 8H2, 8E7, 9C7
9202	042897	Zyl. Schr.	3M11, 3G2	9781	000002	Filterregler	9H2
9203	003037	Zyl. Schr.	4L10	9790	111001	L-Verschraubung	8C5, 8E7
9203	003067	Zyl. Schr.	2D8	9790	200000	Versch.-Gd-E	8J1
9203	003642	Zyl. Schr.	1D3	9790	200001	Versch.-Gd-E	8D6, 8D9, 8H10
9203	003647	Zyl. Schr.	2B8	9790	201000	Versch.-Wi-E	8J4, 8D1
9203	003657	Zyl. Schr.	1B. 1B6, 1C10, 8C7	9790	201001	Versch. Wi-E	8D10, 8G9, 8J10, 9C7
9203	004277	Zyl. Schr.	5E6	9792	051020	Muffe	8D4, 8K7, 9D2
9203	004307	Zyl. Schr.	5C4	9792	071010	Blindstopfen	8C7, 9C6
9203	113701	Flachkopfschr.	4F8, 4F5	9792	102000	Wi-Stück	8K10
9203	113764	Flachkopfschr.	1E3	9792	102010	Wi-Stück	8D4, 8K7, 9C2
9203	123687	Flachkopfschr.	1D12, 2B1, 2C4, 8A3, 8B1	9792	301020	Dichtring	8D4, 8K7
9203	214417	Li. Senkschr.	5B3	9822	510001	Nähleuchte	9F7
9203	312411	Senkschr.	2M3, 2M5	9822	510012	Glasscheibe	9H7
9203	313057	Senkschr.	1B1	9822	642024	Halogenlampe	9H7
9203	313652	Senkschr.	2C8	9825	151001	Stecker	9D3
9203	313657	Senkschr.	2D6	9825	810302	Sicherung	9M8
9203	313667	Senkschr.	8C1	9840	104201	Flachst. Hülse	9K8
9205	023051	Gew. Stift	4D8, 4G1	9840	120003	Nagelschelle	9K7
9205	023658	Gew. Stift	1C7	9840	120205	Bef. Schelle	8C4
9205	101528	Gew. Stift	2L5, 2L3	9840	120207	Bef. Schelle	8C8
9205	102168	Gew. Stift	4J2, 2A6, 2B7	9840	121001	Kabelbinder	8E2, 8J3, 9K9
9205	102178	Gew. Stift	3L3	9840	123003	Stahlnadel	9K7
9205	102468	Gew. Stift	3L3, 3D6	9840	133001	Würgenippel	9K9
9205	102478	Gew. Stift	2H3, 2H5, 1J3, 1K6, 1K8	9840	135001	Gegenmutter	9K9
9205	102488	Gew. Stift	2A9, 1L5, 1K6	9840	302005	Leitung	9J8
9205	102508	Gew. Stift	4M11, 4K11				
9205	102788	Gew. Stift	5E2				
9205	122498	Gew. Stift	2O9, 2O10				
9205	162468	Gew. Stift	4L9				
9206	200087	6kt. Blechschr.	8E8				
9207	161597	Spanpl. Schr.	5E1				
9207	179857	Spanpl. Schr.	8J1				
9210	023757	Rändelschr.	3E11				
9217	000627	Flügelschr.	1G3				
9231	000367	6kt. Mutter	2C4				
9231	000377	6kt. Mutter	2C2, 8J1				
9231	000387	6kt. Mutter	8K6				
9231	000397	6kt. Mutter	3J10				
9231	110037	6kt. Mutter	4D8, 4G1				
9231	110057	6kt. Mutter	8D9				
9231	110107	6kt. Mutter	8H4				