

三菱工業用ミシン部品カタログ

MITSUBISHI Industrial Sewing Machine Parts Catalog

Model LT2-220MOB
LT2-220BOB
LT2-230M1TW
LT2-230B1T

目次	INDEX	Page
① 本体部分	Body and it's accessories	2
② 糸調節器部分	Thread tension regulator mechanism	4
③ 上軸・押え・ひざ上げ機構	Upper shaft & Presser foot mechanism	6
④ 天秤・針棒揺動機構	Thread take-up lever & Needle bar rock motion mechanism	8
⑤ 縫目加減機構	Stitch regulator mechanism	10
⑥ 下軸・送り機構	Lower shaft & Feed rock shaft mechanism	12
⑦ カマ台機構	Hook saddle mechanism	14
⑧ 糸切り機構 (I)	Knife mechanism (I)	16
⑨ 糸切り機構 (II)	Knife mechanism (II)	18
⑩ タッチバックおよび検出器機構	Touch back & Detector mechanism	20
⑪ ワイパー機構	Wiper mechanism	22
⑫ 給油機構	Oil lubrication mechanism	24
⑬ 付属品	Accessories	26
⑭ ゲージ部品表	Gauge parts list	28



ミシン用部品コード採番基準 MITSUBISHI SPARE PARTS No.Designation system

注：※欄には英文字(A,B……X,Y,Z)が入る。
Remarks: Alphabet(A,B……X,Y,Z) should be taken at ※ mark.

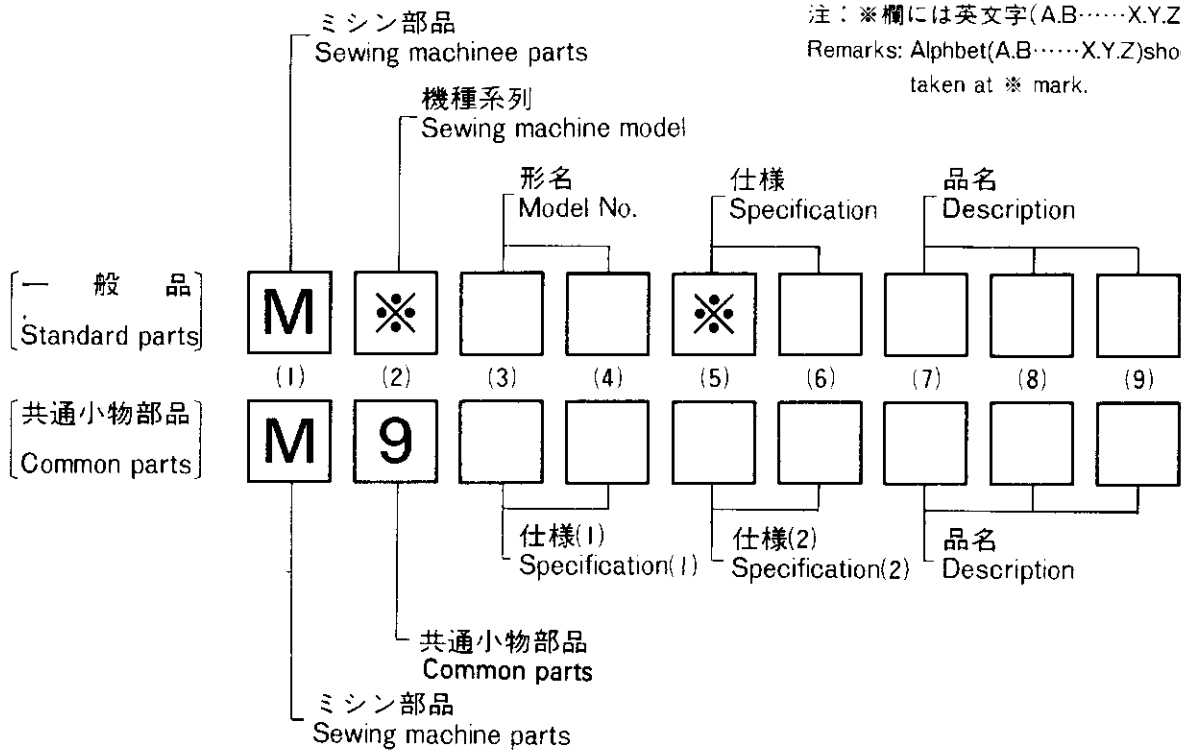

例
Example

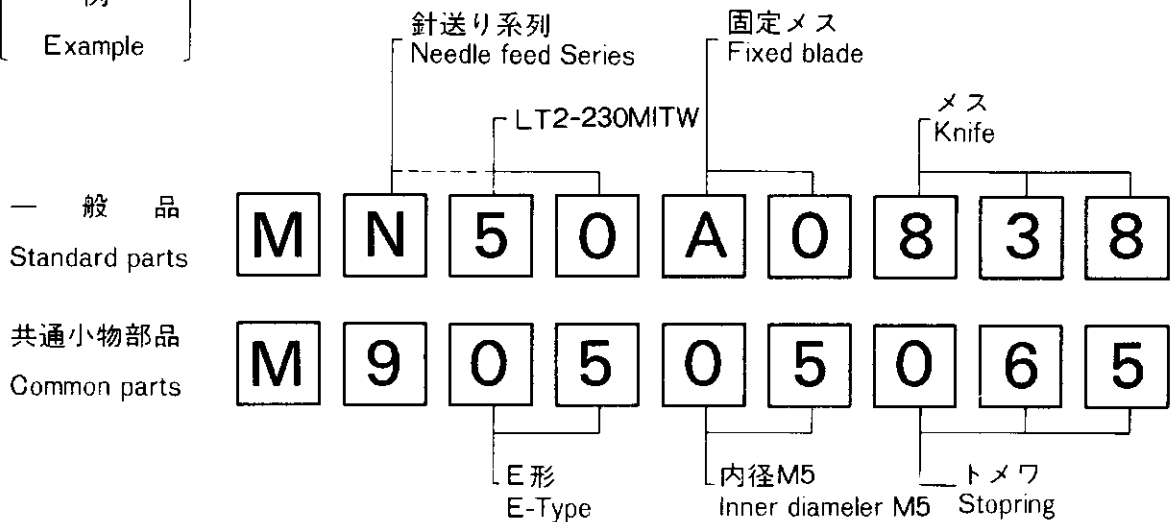

注：一般品についての機種形名は、その部品が最初に使用された機種形名を示します。従って長期に亘る場合は、機種の変更が行われるため、当初の機種以外の機種で使用されている場合があります。
Sewing machine Models, of Standard Parts are indicated model of these parts are registered firstly. Parts are used for not only the indicated model, but also another models. in reason of New development, Improvement after.

● 全体構成
CONSTRUCTION

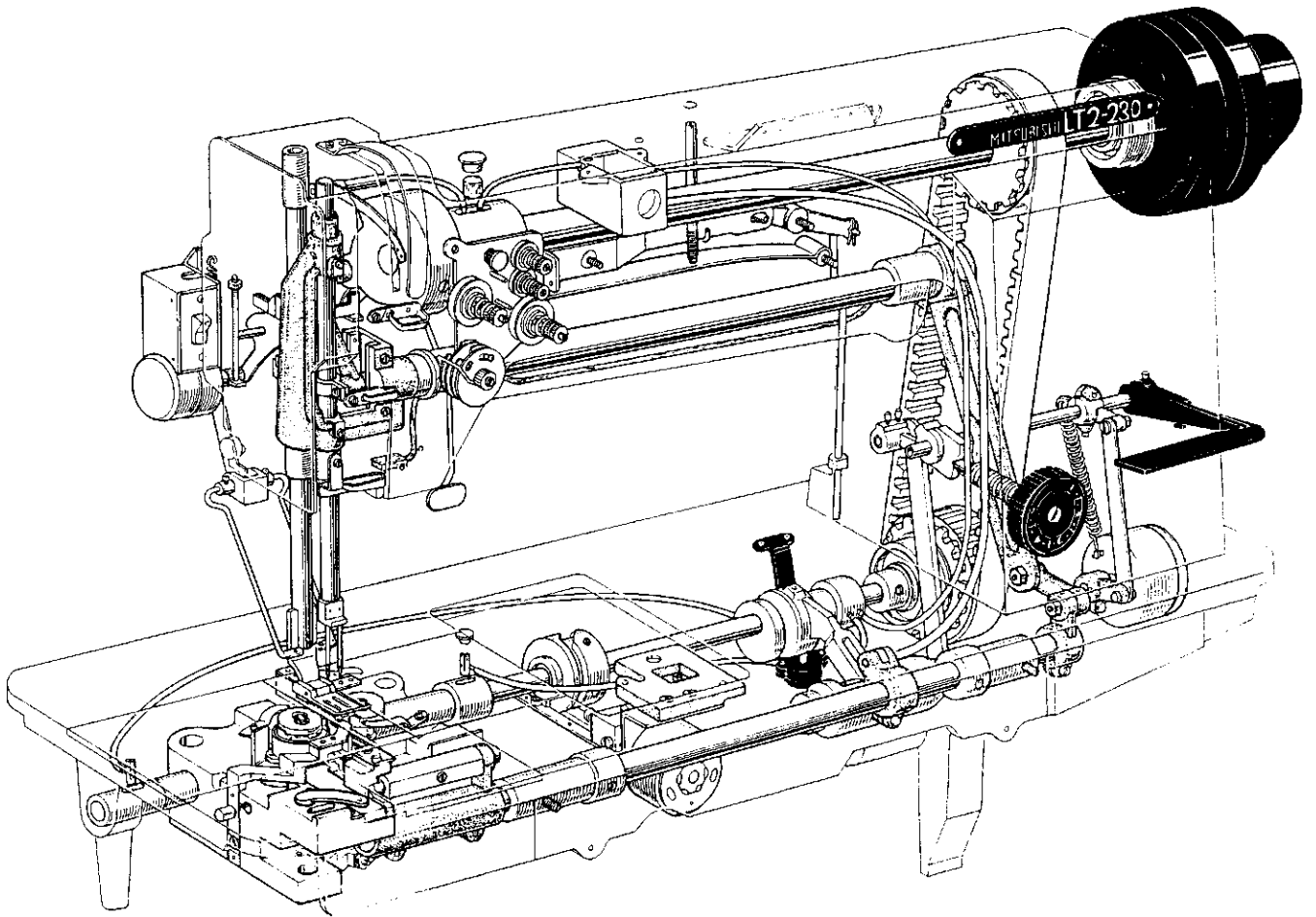

1 本体部分
BODY AND IT'S ACCESSORIES

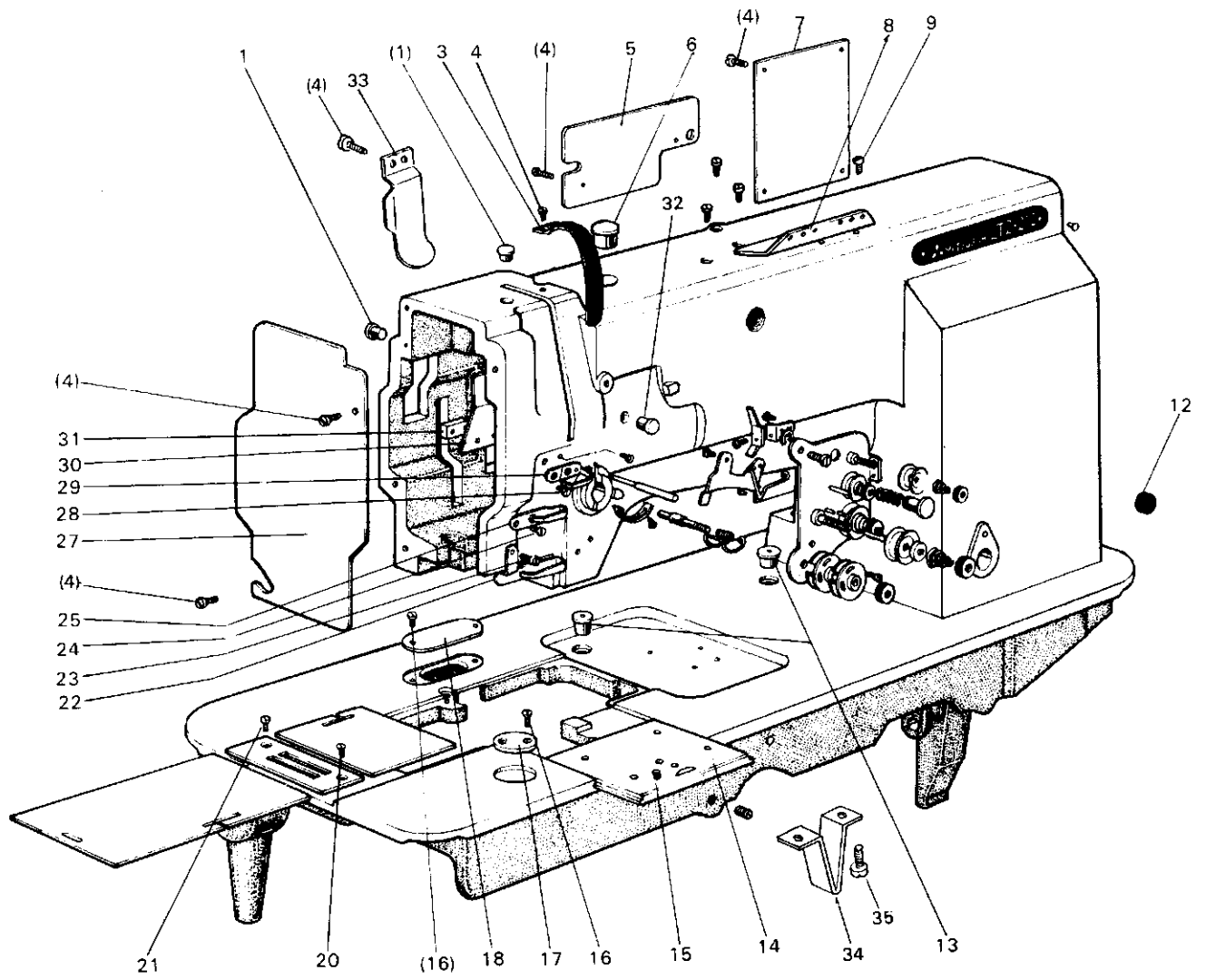

1 本体部分

BODY AND IT'S ACCESSORIES

Fig. No.	部品コード Part.No.	部 品 名	Description	使用個数 Amt. Req.				資財コード Ref. No.
				LIT-220 MOB	LIT-220 BOB	LIT-230 LIT-230 LIT-230	LIT-230 BIT	
1	M9 0880 080	ゴム セン	φ10.8.....Rubber plug φ10.8.....	3	3	3	3	W501320-H01
3	MN 10A0 584	天ビンカバThread take-up cover.....	1	1	1	1	W479316-H01
4	M9 1110 002	平ネ	1/4(40)×8.....Screw 1/4(40)×8.....	11	11	11	11	W500294-H01
5	MN 40A0 880	横蓋Side cover.....	1	1			A140D077H03
	MN 50A0 880	横蓋Side cover.....		1	1		A140D077H04
6	M9 1302 080	ゴム セン	φ13.....Rubber plug φ13.....	1	1	1	1	W488504-H02
7	MN 40A0 237	裏蓋Rear cover.....	1	1	1	1	A140D078H01
8	MN 40A0 180	糸案内Thread guide.....	1	1	1	1	A141D143H01
9	M9 1116 002	平ネ	1/4(40)×8.....Screw 1/4(40)×8.....	2	2	2	2	W501400-H01
12	M9 1603 080	ゴム セン	φ14.....Rubber plug φ14.....	1	1	1	1	W476428-H01
13	MN 10A4 742	蓋	(オイルカップ).....Cap.....	2	2	2	2	W462905-H01
14	MN 40A0 472	スベリ板	(組).....Slide plate (front).....	1	1			A130C019G01
	MN 50A0 472	スベリ板	(組).....Slide plate (front).....		1	1		A130C078G01
15	M9 1301 001	止メネ	1/4(32)×4.8.....Screw 1/4(32)×4.8.....	1	1	1	1	W501005-H01
16	M9 0916 011	皿ネ	1/4(40).....Screw 1/4(40).....	4	4			A140D550H01
17	MN 50A5 742	蓋Cover.....	1	1			A141D103H03
18	MN 50A4 742	蓋Cover.....	1	1			A140D168H01
20	M9 1102 011	丸皿ネ	1/4(40)×8.....Screw 1/4(40)×8.....	1	1	1	1	W502948-H01
21	M9 0951 003	丸平ネ	1/4(36)×6.5.....Screw 1/4(36)×6.5.....	1	1	1	1	W501004-H01
22	MN 10A3 181	糸案内Thread guide.....	1	1	1	1	W446710-H01
23	M9 0920 002	平ネ	1/4(40)×6.5.....Screw 1/4(40)×6.5.....	1	1	1	1	W501523-H01
24	M9 0904 011	丸皿ネ	1/4(40)×6.5.....Screw 1/4(40)×6.5.....	1	1	1	1	W500147-H01
25	MN 10A1 181	糸案内Thread guide.....	1	1	1	1	W445858-H01
26	M9 1101 035	ツマミネ	1/4(40)×8.....Thumb Screw 1/4(40)×8.....	1	1	1	1	A140D338H01
27	MN 40A0 830	面板Face plate.....	1	1	1	1	A130C061H02
28	M9 1201 011	丸皿ネ	3/8(28)×11.....Screw 3/8(28)×11.....	2	2	2	2	W500993-H01
29	MN 10A0 181	糸案内Thread guide.....	1	1	1	1	W445857-H01
30	MN 10A0 131	油受けOil guard plate.....	1	1	1	1	W445863-H01
31	MN 10A0 476	スペーサSpacer.....	1	1	1	1	W445874-H01
32	M9 1303 080	ゴム セン	φ13.....Rubber plug φ13.....	1	1	1	1	A141D577H01
33	MN 40A0 339	カバーCover.....	1	1	1	1	A141D410H01
34	MN 50A0 426	支工Supportor.....	1	1	1	1	A141D142H01
35	M9 1601 003	丸平ネ	1/4(24)×9.....Screw 1/4(24)×9.....	2	2			W466240-H01

2 上糸調節器部分
THREAD TENSION REGULATOR MECHANISM

LT2-230

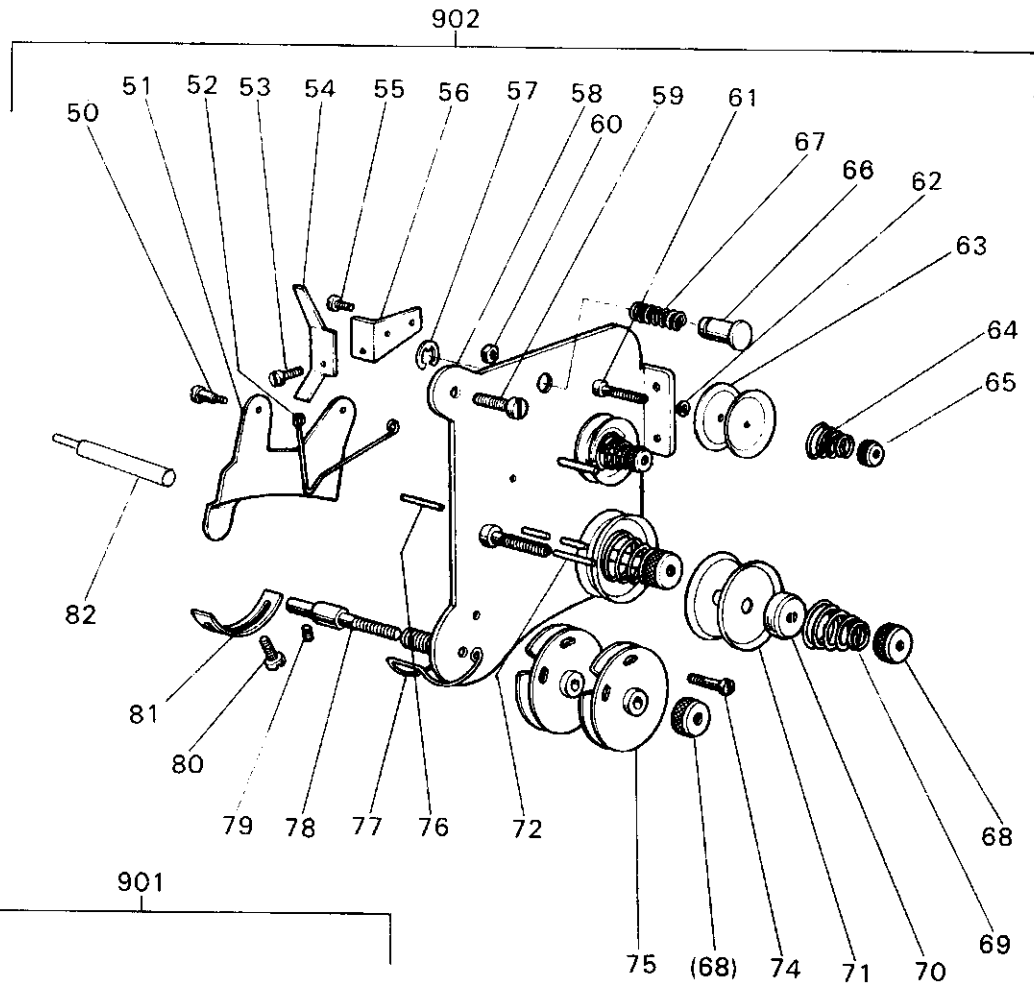

LT2-220

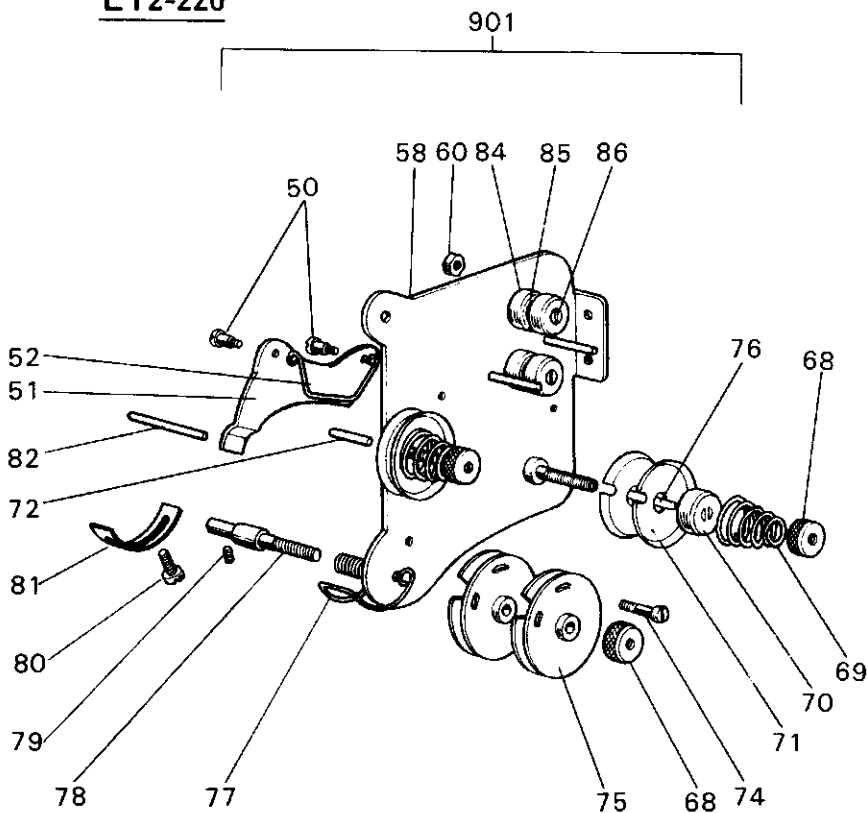

② 上糸調節器部分

THREAD TENSION REGULATOR MECHANISM

Fig. No.	部品コード Part.No.	部 品 名	Description	使用個数 Amt. Req.				資財コード Ref. No.
				LTZ-220 MIB	L12-220 IACB	L12-230 E12-230 BIT		
901	MN 40E0 210	上糸調節器組	Thread tension regulator completem	1				W225101-G05
	MN 42E0 210	上糸調節器組	Thread tension regulator completem	1				W225101-G06
902	MN 50E1 210	上糸調節器組	Thread tension regulator completem	1				A120B194G05
	MN 52E1 210	上糸調節器組	Thread tension regulator completem	1				A120B194G06
50	M9 0902 015	平ネジ段付	1/4(40) Screw 1/4(40)	2	2	2		W501026-H01
51	MN 10A0 220	糸ユルメ	Tension releasing plate	1	1			W450020-H01
	MN 50E0 220	糸ユルメ	Tension releasing plate	1	1			A141D132G01
52	MN 10A0 851	センサイクバネ	Tension releasing spring	1	1	1		W502148-H01
53	M9 0927 015	平ネジ段付	1/4(40)×4.2 Screw 1/4(40)×4.2	1	1	1		A141D135H01
54	MN 50A5 950	レバ	Lever	1	1			A141D133H01
55	M9 0906 002	平ネジ	1/4(40)×4.5 Screw 1/4(40)×4.5	1	1	1		W500791-H01
56	MN 50A6 601	取付板	Mounting plate	1	1	1		A141D134H02
57	M9 0505 065	E形止メ輪	E-type stopring 5	1	1			S592411H05
58	MN 25E0 601	取付板組立	Mounting plate complete	1	1			W462823-G01
	MN 50E0 601	取付板組立	Mounting plate complete	1	1			W462823-G02
59	M9 1110 002	平ネジ	1/4(40)×8 Screw 1/4(40)×8	1	1	1		W500294-G01
60	M9 0901 045	ナット	1/4(40) Nut 1/4(40)	2	2			W500307-H01
	M9 1105 045	ナット	1/4(40) Nut 1/4(40)	1	1			W500657-H01
61	MF 10A1 553	調節子	Thread tension stdnd	2	2			W502171-H01
62	M9 0401 050	座金	Washer 4	1	1			B508956-H01
63	MN 50A0 555	調節子皿	Thread tension disc	4	4			A140D383H01
64	MN 50A1 245	エンスイバネ	Spring	2	2			A140D382H01
65	M9 1609 046	ツマミナット	1/4(40) Thumb nut 1/4(40)	2	2			A140D158H01
66	MP 41A0 270	押しボタン	Push button	1	1			A141D136H01
67	MN 50A4 572	ツル巻バネ	Spring	1	1			A141D137H01
68	M9 1603 046	ツマミナット	1/4(40) Thumb nut 1/4(40)	3	3	3		W502940-H01
69	MN 10A3 245	エンスイバネ	Spring	2	2			W461785-H01
	MF 10A0 245	エンスイバネ	Spring	2				W450071-H01
	MN 52A1 245	エンスイバネ	Spring		2			A140D843H01
70	MN 10A0 556	調節子皿	Thread tension releasing disc	2	2	2		W445934-H01
71	MN 10A0 555	調節子皿	Thread tension disc	4	4	4		W445933-H01
72	M9 0202 060	ピン	Pin	1	1	1		W502064-H01
74	M9 0603 003	丸平ネジ	3/8(56)×12 Screw 3/8(56)×12	1	1	1		W502062-H01
75	MN 10E0 175	取付板組立	Plate complete	2	2	2		W462825-G01
76	MN 25A0 220	ピン	Pin	1	1	1		W462824-H01
77	MN 10A0 187	糸取りバネ	Thread take-up spring	1	1	1		W450012-H02
78	MN 10A0 554	調節子軸	Tension tension stud	1	1	1		W450011-H01
79	M9 1513 001	止メネジ	3/8(28)×11 Screw 3/8(28)×11	1	1	1		B509060-H01
80	M9 0907 002	平ネジ	1/4(40)×5 Screw 1/4(40)×5	1	1	1		W500076-H01
81	MN 10A0 447	ストッパ	Stopper	1	1	1		W445942-H01
82	M9 0514 060	糸ユルメピン	Tension releasing Pin	1	1			A140D199H01
	M9 0516 060	糸ユルメピン	Tension releasing Pin	1	1			A141D094H01
84	MN 10A0 155	案内台	Thread guide bracket	2	2			W502213H01
	MN 10A1 555	案内台	Thread guide disc	2	2			W502212H01
86	M9 0930 016	丸平ネジ段付(組)	Screw	2	2			W462822G01

③ 上軸、押え、ひざ上げ機構

UPPER SHAFT & PRESSER FOOT MECHANISM

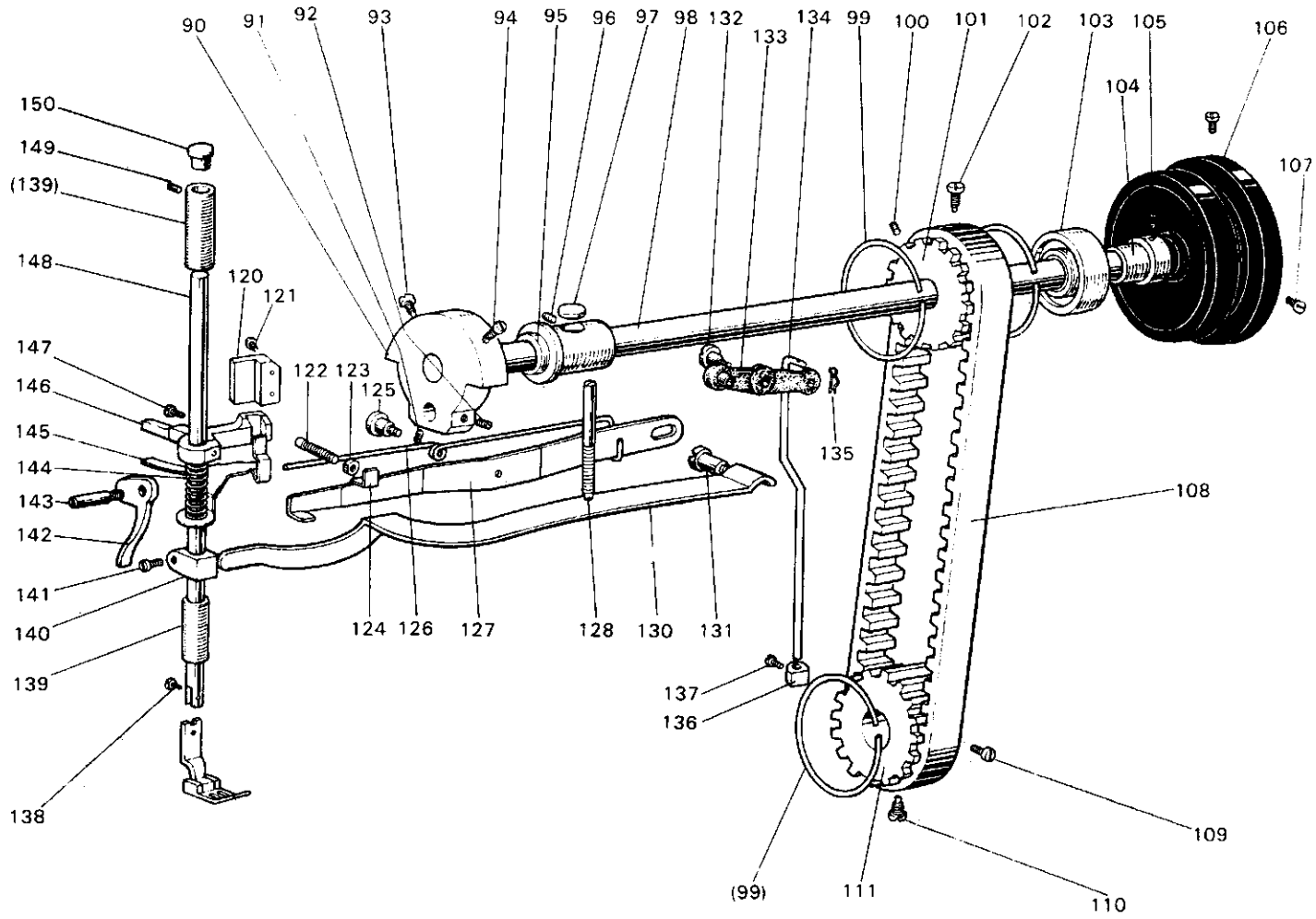

③ 上軸、押え、ひざ上げ機構

UPPER SHAFT & PRESSER FOOT MECHANISM

Fig. No.	部品コード Part.No.	部 品 名	Description	使用個数 Amt. Req.				資材コード Ref. No.
				L77-220 M10B	L177-220 L177-230 BOB	L177-230 L177-250 PLT	BIT	
90	ML 65B0 383	ク ラ ン ク	Crank	1	1			W464419-H01
	MN 42A0 383	ク ラ ン ク	Crank	1	1			W462915-H01
91	M9 1602 001	止 メ ネ ジ	Screw 1/4(40) × 3.5	1	1	1	1	W500036-H01
92	M9 1606 001	止 メ ネ ジ	Screw 1/4(40) × 7	1	1	1	1	B504016-H01
93	M9 1802 006	平 ネ ジ 棒 先	5/8(28) × 14	1	1	1	1	B503851-H01
94	M9 1801 002	平 ネ ジ	5/8(28) × 13	1	1	1	1	W500306-H01
95	MN 40A0 231	上 軸 メ タ ル (左)	Arm shaft bushing (left)	1	1	1	1	W481659-H07
96	M9 1654 001	止 メ ネ ジ	Screw 1/4(24) × 13	1	1	1	1	W501017-H01
97	MN 10A6 740	フ ェ ル ト	Felt	1	1	1	1	W478164-H01
98	MN 40A0 230	上 軸	Arm shaft	1	1			A130C062H03
	MN 50A0 230	上 軸	Arm shaft			1	1	A130C062H04
99	MN 10A1 851	センサイクバネ	Spring flange	3	3	3	3	B411094-H01
100	M9 1513 001	止 メ ネ ジ	5/8(28) × 9	1	1	1	1	B509060-H01
101	MN 40A0 767	歯 型 ベ ル ト 車 (上)	Pully (upper)	1	1			A140D080H01
	MN 50A0 767	歯 型 ベ ル ト 車 (上)	Pully (upper)			1	1	A140D522H01
102	M9 1501 007	丸 平 ネ ジ 棒 先	5/8(28) × 14.5	1	1	1	1	B509256-H01
103	MN 10A1 456	軸 受 ケ	Ball bearing	1	1	1	1	W445869-H01
104	MN 40A1 750	プ ッ シ ュ	Bushing	1	1	1	1	A140D082H01
105	M9 1516 002	平 ネ ジ	5/8(28) × 8.5	2	2	2	2	W502945-H02
106	MN 40A0 682	ハ ズ ミ 車	Balance wheel	1	1			A130C191G02
	MN 50A0 682	ハ ズ ミ 車	Balance wheel			1		A130C191G01
	MN 52A0 682	ハ ズ ミ 車	Balance wheel				1	A130C620G01
107	M9 1520 002	平 ネ ジ	5/8(28) × 12	2	2	2	2	A141D751H01
108	MN 10A0 523	歯 型 ベ ル ト	Cog belt	1	1	1	1	P614007X01
109	M9 1501 003	平 ネ ジ	5/8(28) × 10	1	1	1	1	B508963-H01
110	M9 1503 007	丸 平 ネ ジ 棒 先	5/8(28) × 10.5	1	1	1	1	W501212-H01
111	MN 10A0 768	歯 型 ベ ル ト 車 (下)	Pulley (lower)	1	1			W447044-H01
	MN 50A0 768	歯 型 ベ ル ト 車 (下)	Pulley (lower)			1	1	A140D523H01
120	MN 50A0 265	押エ棒ダキガイド	Guide	1	1	1	1	A140D087H01
121	M9 1112 002	平 ネ ジ	1/2(40) × 12	2	2	2	2	W501889-H01
122	M9 1657 002	平 ネ ジ	1/4(24) × 21.9	1	1	1	1	A140D088H01
123	M9 1601 045	ナ ッ ト	1/4(24)	1	1	1	1	W501989-H01
124	MN 50A1 477	ス ト ッ パ	Stopper			1		A140D619H01
125	M9 1601 016	丸 平 ネ ジ 段 付	1/4(24) × 14	1	1	1	1	W501020-H01
126	MN 10A0 729	ヒ ネ リ バ ネ	Twist spring	1	1	1	1	W445922-H01
127	MN 40A0 725	ヒザ上げレバー	Knee lifter lifting lever	1	1	1	1	A130C068H01
128	M9 1601 033	ピ ン ネ ジ	1/4(40) × 79	1	1	1	1	W445917-H01
130	MN 10A0 258	イ タ バ ネ	Lever spring	1	1	1	1	W319992-H02
131	M9 1602 016	丸 平 ネ ジ 段 付	1/4(24) × 13	1	1	1	1	W501006-H01
132	M9 1606 016	丸 平 ネ ジ 段 付	1/4(24) × 14	1	1	1	1	A140D092H01
133	MN 40E0 724	ヒザ上げ腕 (組)	Knee lifter lifting lever complete	1	1	1	1	A130C081G01
134	MN 40A0 511	操 作 棒	Operation rod	1	1	1	1	A140D093H01
135	M9 0601 065	ス ナ ッ プ ピ ン	Snap pin	1	1	1	1	S921N020P06
136	MN 10A0 352	カ ラ ー	Collar	1	1	1	1	W445924-H02
137	M9 1107 002	平 ネ ジ	1/8(40) × 5.5	1	1	1	1	W500092-H01
138	M9 0851 015	平 ネ ジ 段 付	1/8(44) × 9	1	1	1	1	W501007-H01
139	MP 00B0 267	押エ棒メタル	Bushing	2	2	2	2	W445929-H02
140	MN 10A0 702	バ ネ 受 ケ	Spring bracket	1	1	1	1	W445921-H01
141	M9 0905 002	平 ネ ジ	5/8(40) × 8.5	1	1	1	1	W500470-H01
142	MN 10A0 252	押エ上ゲレバー	Lifter lever	1	1	1	1	W459307-H01
143	M9 1201 033	ピ ン ネ ジ	3/8(28) × 24.5	1	1	1	1	W501024-H01
144	MP 00B0 572	ツルマキバネ	Spring	1	1			W502465H01
145	MN 40A0 221	糸 ユ ル メ	Thread releasing plate	1	1			A130C067H01
146	MN 40A0 265	押エ棒ダキ	Bracket	1	1	1	1	A130C066H01
147	M9 1113 002	平 ネ ジ	1/8(40) × 15	1	1	1	1	W500182-H01
148	MN 10A0 262	押エ棒	Presser bar	1	1	1	1	W445919-H02
149	M9 1653 001	ト メ ネ ジ	1/4(24) × 8	2	2	2	2	W500478-H01
150	M9 0880 080	ゴ ム 栓	Rubber plug φ 10.8	1	1	1	1	W501320-H01

4 天秤・針棒揺動機構

THREAD TAKE-UP LEVER & NEEDLE BAR ROCK MOTION MECHANISM

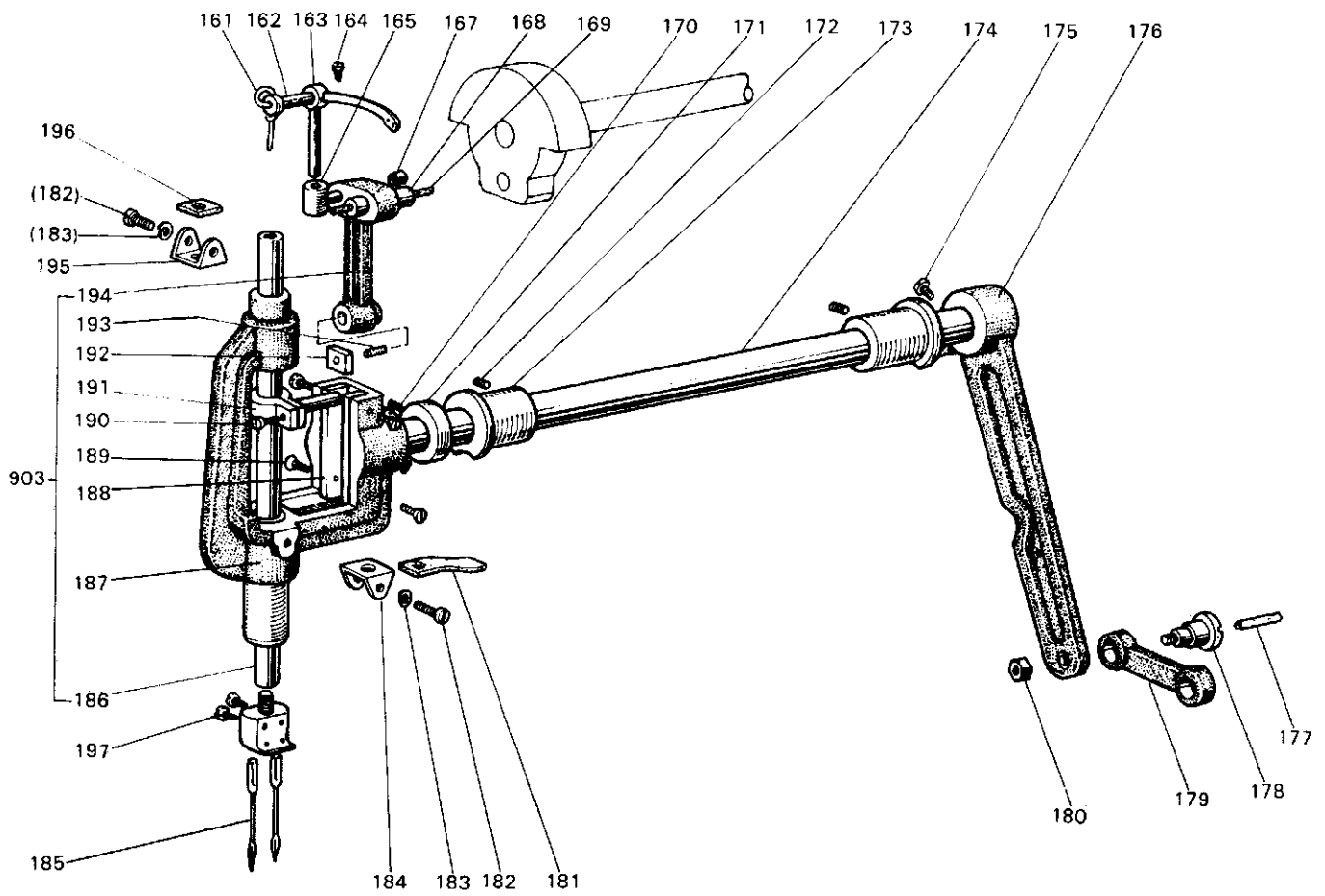

4 天秤・針棒揺動機構

THREAD TAKE-UP LEVER & NEEDLE BAR ROCK MOTION MECHANISM

Fig. No.	部品コード Part.No.	部 品 名	Name of Part	使用個数 Amt. Req.				資財コード Ref. No.	
				L72-220 MOB	L72-220 L72-230 MITW	L72-230 BIT			
161	MF 10E2 148	ヒ モ	2.5 φ × 240	Oil wick φ 2.5 × 240	1	1	1	1	W444138H01
162	MN 10A0 587	支 工 軸		Thread take-up guide bracket pin	1	1	1	1	W445883H1
163	MN 40A0 582	天 ビ ン		Thread take-up lever	1	1			W445882H02
	MN 12B0 582	天 ビ ン		Thread take-up lever		1	1		W462828H01
164	M9 1502 002	平 ネ ジ	5/16(28) × 12	Screw 5/16(28) × 12	1	1	1	1	W500509H01
165	MN 10A0 588	ス ベ リ ガ ネ		Thread take-up link	1	1	1	1	W445881H02
167	MN 10A0 500	セ ネ		Plug	1	1	1	1	W501275H01
168	MN 10A0 387	軸	(クランクピン)	Needle bar crank Pin	1	1	1	1	W445866H01
169	MN 10E3 148	ヒ モ		Oil wick	1	1	1	1	W500231H01
170	M9 1108 001	止 メ ネ ジ	5/16(40)	Screw 5/16(40)	2	2	2	2	B503846H01
171	MN 50A0 352	カ ラ		Collar	1	1	1	1	A140D085H01
172	M9 1653 001	ト メ ネ ジ	1/4(24) × 8	Screw 1/4(24) × 8	2	2	2	2	W500478H01
173	MN 40A0 669	針棒揺動軸メタル		Needle bar rock shaft bushing	2	2	2	2	A140D073H01
174	MN 40A0 668	針 棒 揺 動 軸		Needle bar vibrating shaft	1	1	1	1	A140D084H01
175	M9 1603 003	丸 平 ネ ジ	1/4(24) × 16	Screw 1/4(24) × 16	1	1	1	1	W501009H01
176	MN 40A0 672	針 棒 揺 動 腕		Needle bar rock shaft crank	1	1	1	1	A130C065H02
177	MF 10E2 148	ヒ モ	φ 2.5 × 85	Oil wick φ 2.5 × 85	1	1	1	1	W462978H01
178	M9 2001 015	平 ネ ジ 段 付	5/16(24) × 26.2	Screw 5/16(24) × 26.2	1	1	1	1	W501010H01
179	MN 40A0 956	レ ン セ ッ カ ン		Link	1	1	1	1	A140D086H02
180	M9 2001 045	ナ ッ ト	5/16(24)	Nut 5/16(24)	1	1	1	1	W501512H01
181	MN 50A0 740	フ エ ル ト		Felt	1	1	1	1	W478166H01
182	M9 0805 002	平 ネ ジ	1/8(44) × 4.5	Screw 1/8(44) × 4.5	4	4	4	4	B508852H01
183	M9 0103 053	バ ネ ザ ガ ネ	3	Spring washer 3	4	4	4	4	S913N210P02
184	MN 10A6 689	ホ ル ダ		Holder	1	1	1	1	W445945H01
185	MV 01A0 128	ミ シ ン 針	DP × 5 -14	Needle DP × 5 # 14	2	2			S970004H02
	MN 10A1 128	ミ シ ン 針	DP × 5 -18	Needle DP × 5 # 18	2	2			S970004H03
903	MN 40E0 666	支 工 (組)		Needle bar rock frame complete	1	1	1	1	A130D063G02
186	MN 10A0 660	針 棒		Needle bar	1	1	1	1	W445878H01
187	MN 40E1 666	支 工		Needle bar rock frame	1	1	1	1	A130C080G01
188	MN 10A1 476	ス ベ ー サ		Spacer	2	2	2	2	W445873H01
189	M9 0604 011	丸 皿 ネ ジ	3/16(56) × 4	Screw 3/16(56) × 4	4	4	4	4	W501205H01
190	M9 0905 002	平 ネ ジ	5/16(40) × 8.5	Screw 5/16(40) × 8.5	1	1	1	1	W500470H01
191	MN 10A0 665	針 棒 ダ キ		Needle bar connecting stud	1	1	1	1	W445877H01
192	MN 40A1 325	角 駒		Square block	1	1	1	1	A140D552H01
193	MN 10A0 740	フ エ ル ト		Felt	1	1	1	1	W500499H01
194	MN 40A3 956	レ ン セ ッ カ ン		Needle bar connecting link	1	1	1	1	A130C249H01
195	MN 10A5 689	ホ ル ダ		Holder	1	1	1	1	W445944H01
196	MN 40A1 740	フ エ ル ト		Felt	1	1	1	1	W478165H01
197	M9 0935 003	丸 平 ネ ジ		Screw	2	2	2	2	W500991H01

5 縫目加減機構
STITCH REGULATOR MECHANISM

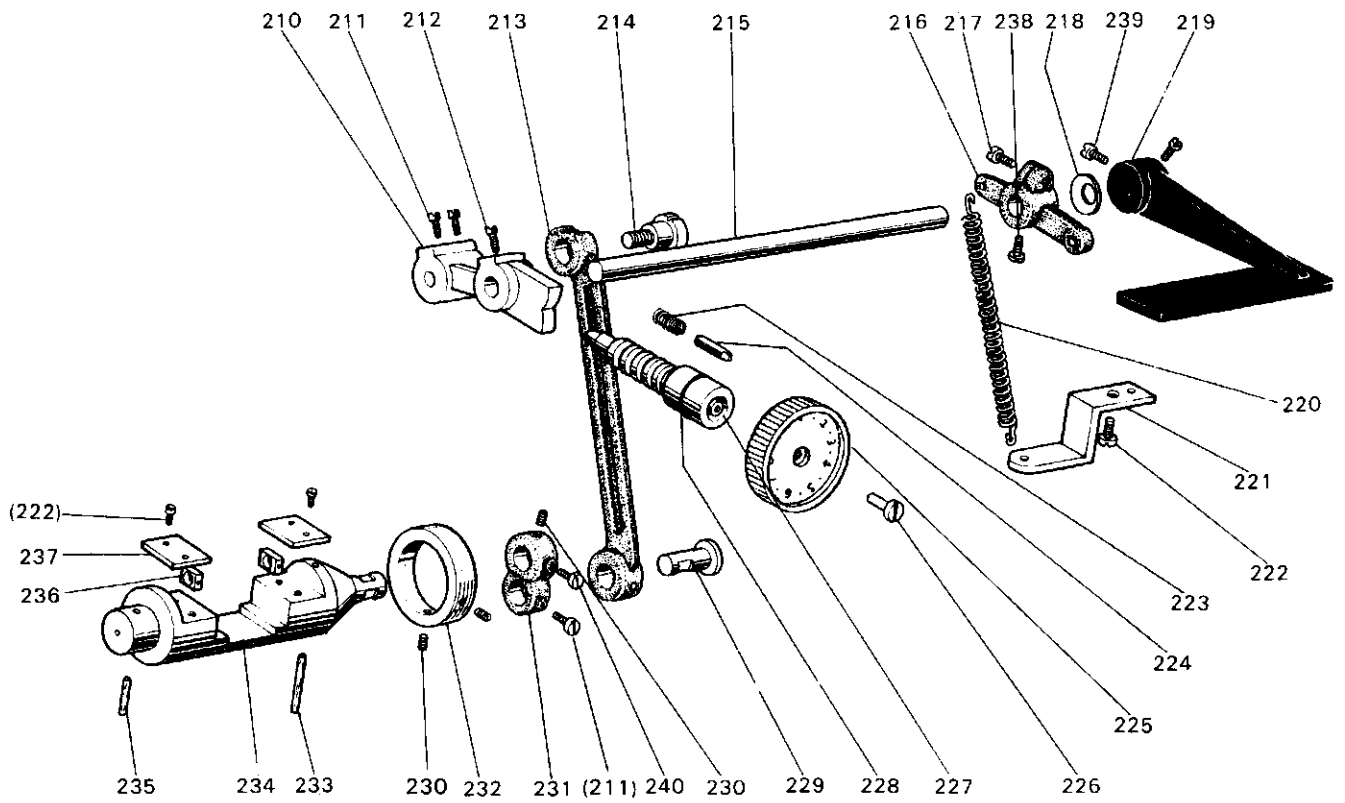

5 縫目加減機構 STITCH REGULATOR MECHANISM

Fig. No.	部品コード Part.No.	部 品 名	Description	使用個数 Amt. Req.			資財コード Ref. No.
				L12-220 M12-220 L12-230 M12-230 L12-230 M12-230			
210	MN 40A0 291	送り調節カム	Feed regulator	1	1	1	A130C069H01
211	M9 1516 002	平ネジ	Screw $\frac{5}{16}$ (28) × 8.5	3	3	3	W502945-H02
212	M9 1505 007	丸平ネジ棒先	Screw $\frac{5}{16}$ (28) × 12	1	1	1	A141D013H01
213	MN 40A2 956	連接桿	Connecting link	1	1	1	A140D508H01
214	MN 40A0 761	偏心軸	Eccentric shaft	1	1	1	A140D095H02
215	MN 40A1 320	返し縫イ軸上	Reverse stitch shaft (upper)	1	1		A141D012H01
	MN 40A0 320	返し縫イ軸上	Reverse stitch shaft (upper)	1	1		A141D012H02
216	MN 40A0 228	腕	Arm	1	1		A130C163H01
	MN 50A6 228	腕	Arm	1	1		A140D097H02
217	M9 1503 003	丸平ネジ	Screw $\frac{5}{16}$ (28) × 13	1	1	1	W501002-H01
218	M9 5003 053	バネ座金	Spring washer	1	1		B503895-H01
219	MN 40A0 632	縫目加減レバー	Reverse sewing lever	1	1		A130C163H01
	MN 50A0 632	縫目加減レバー	Reverse sewing lever	1	1		A130C164G01
220	MN 40A0 572	ツル巻キバネ	Spring	1	1	1	A140D617H01
221	MN 40A0 154	案内板	Bracket for spring	1	1		A140D099H01
222	M9 1110 002	平ネジ	Screw $\frac{1}{4}$ (40) × 8	5	5	4	W500294-H01
223	MF 10A2 572	ツル巻キバネ	Spring	1	1	1	B509164-H01
224	MF 80A0 852	ピン	Pin	1	1	1	W481688-H02
225	MF 10A0 631	ダイヤル	Dial	1	1		W331475-H01
	MP 41A0 631	ダイヤル	Dial	1	1		A130C269H01
226	M9 1209 002	平ネジ	Screw $\frac{3}{8}$ (28) × 6.6	1	1	1	B503887-H01
227	MF 90A0 640	送り調節ネジ	Screw bar	1	1	1	W484899-H02
228	M9 1000 085	Oリング	O-ring ϕ 10	1	1	1	S932N110P09
229	M9 0907 060	ピン	Pin	1	1	1	W502476-H04
230	M9 1506 001	止メネジ	Screw $\frac{5}{16}$ (28) × 6	3	3	3	B509087-H01
231	MN 40A0 634	縫目加減腕下	Stitch regulating crank (lower)	1	1	1	A140D521H01
232	MN 45A0 352	カラ	Collar	1	1	1	A140D506H01
233	MP 40A1 740	フェルト	Felt	1	1	1	A140D739H02
234	MN 45A0 321	返し縫イ台	Reverse bar	1	1	1	A130C231H01
235	MP 40A0 740	フェルト	Felt	1	1	1	A140D739H01
236	MN 40A0 325	角駒	Square block	2	2	2	A140D501H01
237	MN 45A0 154	案内板	Guide plate	2	2	2	A140D502H01
238	M9 1102 002	平ネジ	Screw $\frac{1}{4}$ (40) × 8.5	1	1	1	W500193-H01
239	M9 1519 002	平ネジ	Screw $\frac{5}{16}$ (28) × 7.5	2	2		W502945-H03
240	M9 1515 002	平ネジ	Screw $\frac{5}{16}$ (28) × 10	1	1	1	B508963-H02

⑥ 下軸・送り機構

LOWER SHAFT & FEED ROCK SHAFT MECHANISM

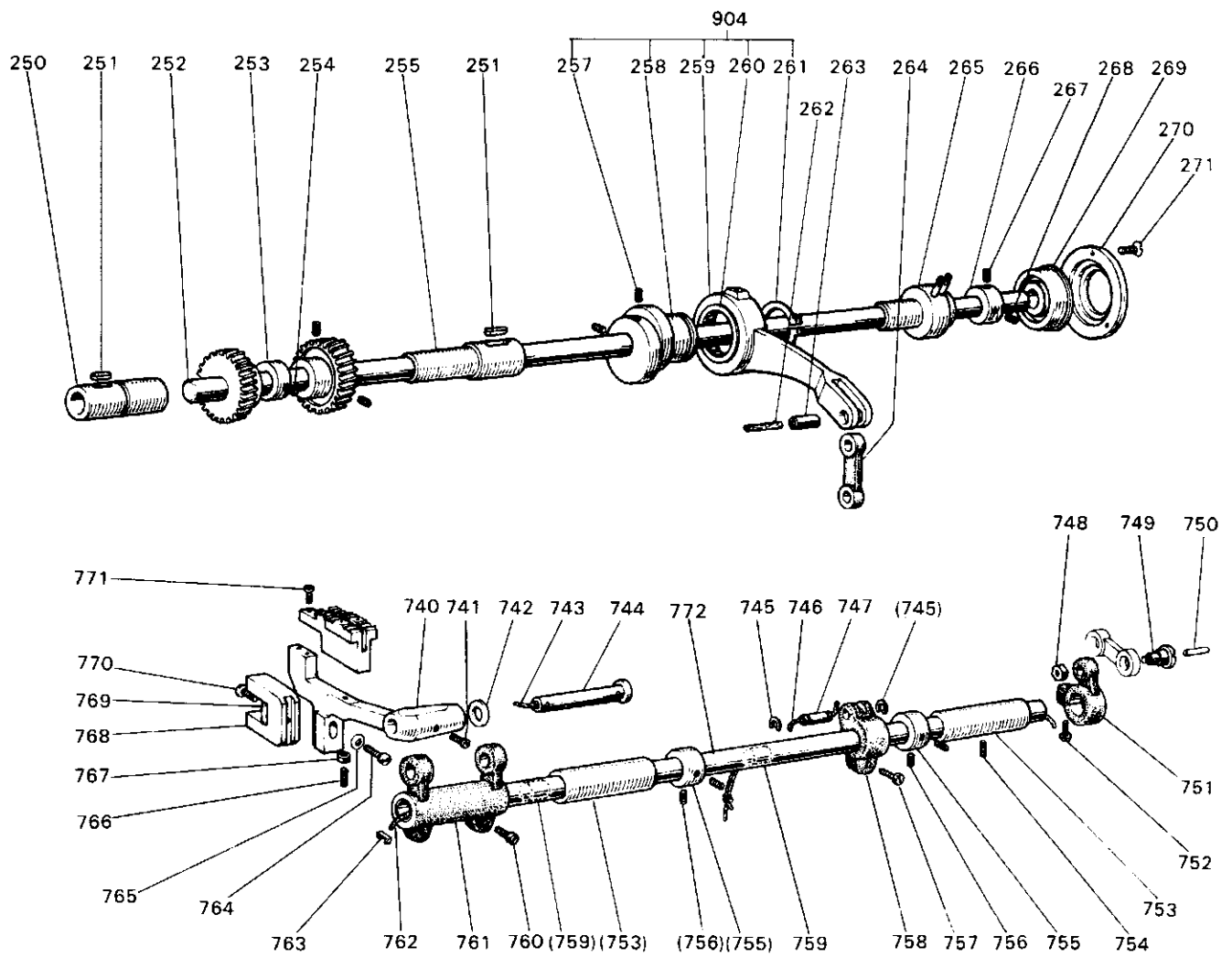

⑥ 下軸・送り機構

LOWER SHAFT & FEED ROCK SHAFT MECHANISM

Fig. No.	部品コード Part.No.	部 品 名 Description	使用個数 Amt. Req.			資財コード Ref. No.
			1000	200	50	
250	MN 10A0 451	下軸メタル(左)	1	1	1	W445890-H01
251	MF 10E0 148	ヒモ	2	2	2	W462978-H01
252	MN 45A0 450	下軸	1	1	1	A130C073H02
253	MN 10A0 292	偏心輪	1	1	1	W445912-H02
254	M9 1603 001	止メネジ棒先	1	1	1	W468269-H01
255	MP 40A0 452	下軸メタル(右)	1	1	1	A140D544H01
904	MN 40E0 305	水平送リカムロッド(組)	1	1	1	A130C103G01
	MN 52E0 305	水平送リカムロッド(組)	1	1	1	A130C103G02
257	M9 1516 001	止メネジ	2	2	2	W500006-H01
258	MN 40A0 492	水平送リカム	1	1	1	A140D111H01
	MN 42A0 492	水平送リカム	1	1	1	A140D111H02
259	MN 40A0 293	送リロッド	1	1	1	A130C230H01
260	MN 40A0 456	軸受	1	1	1	A190D026P01
261	M9 0526 065	C形止メ	1	1	1	S922N010P26
262	MP 40A0 148	ヒモ	1	1	1	A130C259H01
263	MN 40A0 454	軸	1	1	1	A140D503H01
264	MN 40A1 956	連接桿	1	1	1	A140D500H01
265	MP 40E0 453	下軸メタル中(組)	1	1	1	A140D449G01
266	MN 10A0 750	ブッシュ	1	1	1	W445887-H01
267	M9 1602 001	止メネジ	1	1	1	W500036-H01
268	M9 1603 001	止メネジ棒先	1	1	1	W468269-H01
269	MN 10A2 456	軸受	1	1	1	W445886-H01
270	MN 10A0 771	押エ板	1	1	1	W461041-H01
271	M9 0902 011	丸皿ネジ	3	3	3	W500994-H01
740	MN 40A3 281	送リ台	1	1	1	A130C278H03
	MN 50A2 281	送リ台	1	1	1	A130C359H02
741	M9 1110 002	平ネジ	1	1	1	W500294-H01
742	M9 0707 050	座金	1	1	1	A140D429H01
743	MF 10E2 148	ヒモ	1	1	1	W462978H01
744	MP 40A0 283	軸付	1	1	1	A140D116H03
745	M9 0514 065	E形止メ	2	2	2	S922N210P50
746	MP 40A0 148	ヒモ	1	1	1	A130C259H02
747	MN 40A1 454	軸	1	1	1	A140D507H01
748	M9 2001 045	ナット	1	1	1	W501512H01
749	M9 2001 015	平ネジ段付	1	1	1	W501010-H01
750	MF 10E2 148	ヒモ	1	1	1	W462978H01
751	MN 40A0 279	水平送リ腕(右)	1	1	1	A140D114H01
752	M9 1603 003	丸平ネジ	1	1	1	W501009-H01
753	MF 70A0 286	送リ軸メタル	2	2	2	W481663-H01
754	M9 1654 001	止メネジ	2	2	2	W501017-H01
755	MF 70A0 352	カラ	2	2	2	W476422-H01
756	M9 1602 001	止メネジ	4	4	4	W500036-H01
757	M9 1603 003	丸平ネジ	1	1	1	W501009-H01
758	MN 40A0 273	送リ腕(中)	1	1	1	A140D505H01
759	MP 40A2 740	フェルト	2	2	2	A140D539H01
760	M9 1204 003	丸平ネジ	2	2	2	B508978-H01
761	MN 40A0 278	水平送リ腕(左)	1	1	1	A140D115H01
	MN 50A0 278	水平送リ腕(左)	1	1	1	A140D115H03
762	MF 10E2 148	ヒモ	1	1	1	W462987H01
763	MF 80A0 680	クリップ	1	1	1	W501092-H01
764	M9 0508 003	丸平ネジ	1	1	1	W501002-H02
765	M9 0602 050	座金	1	1	1	W502336-H01
766	M9 0851 001	止メネジ	1	1	1	W501001-H02
767	M9 0801 045	ナット	1	1	1	W501210-H01
768	MN 40A0 744	又	1	1	1	A141D222H02
769	MN 10A3 740	フェルト	1	1	1	W501011-H01
770	M9 0804 003	丸平ネジ	1	1	1	W501003-H01
771	M9 0851 002	平ネジ	2	2	2	W501000-H01
772	MN 40A0 491	水平送リ軸	1	1	1	A130C070H02

7 カマ台機構
HOOK SADDLE MECHANISM

LT2-220

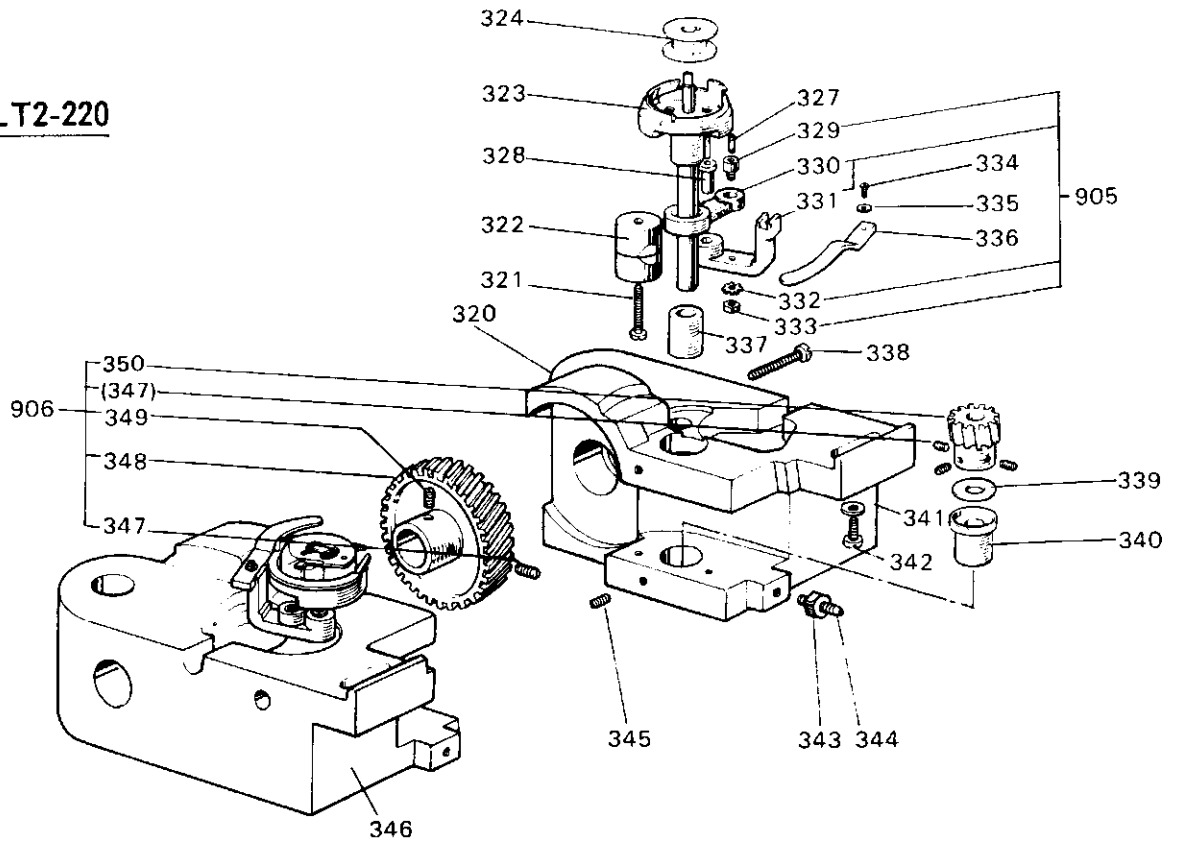

LT2-230

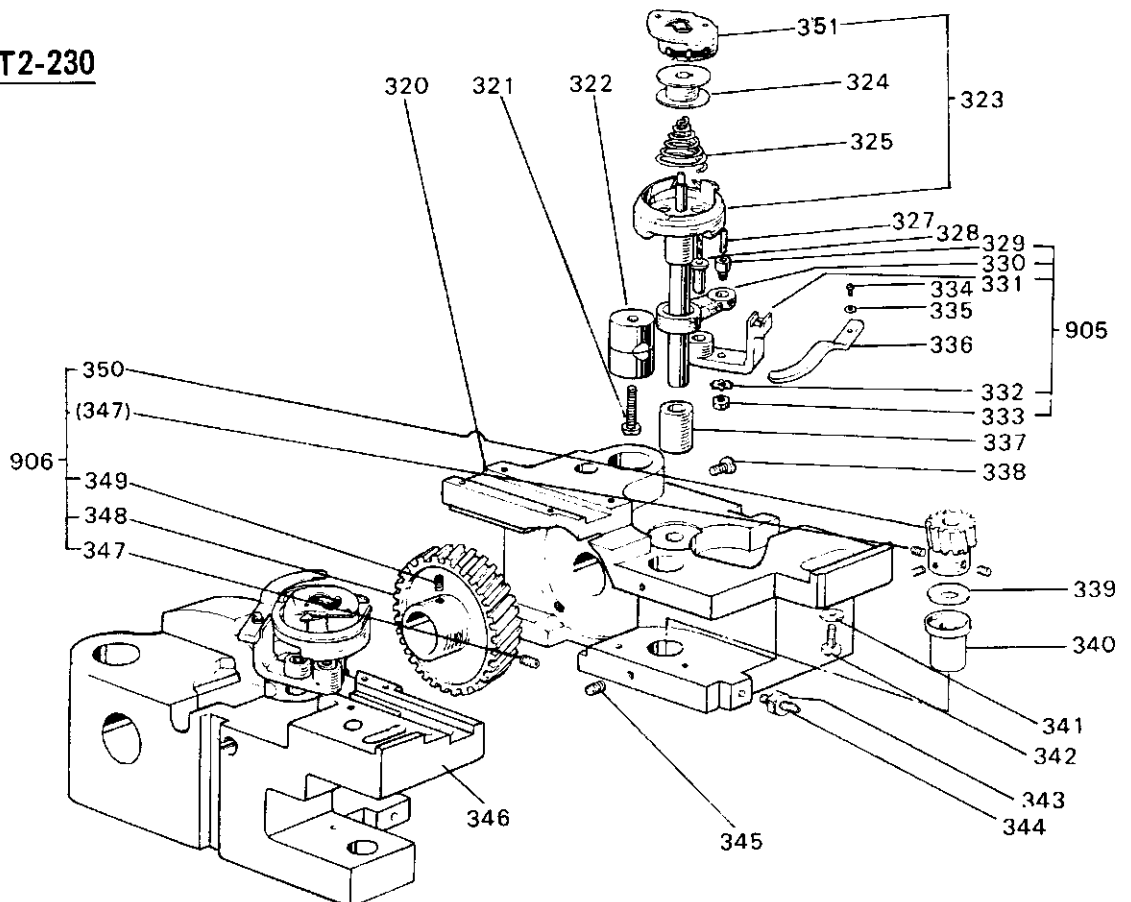

7 カマ台機構

HOOK SADDLE MECHANISM

Fig. No.	部品コード Part.No.	部 品 名	Name of Part	使用個数 Amt. Req				資材コード Ref. No.
				LTZ-220 MCOB	LTZ-220 LUT	LTZ-230 MITW	LTZ-230 BIT	
320	MN 40A0 345	カ マ 台 (右)	Hook saddle (right)	1				A120B017H01
	MP 40A0 345	カ マ 台 (右)	Hook saddle (right)	1				A120B018H01
	MN 60A0 345	カ マ 台 (右)	Hook saddle (right)		1			A120B180H01
	MN 60A1 345	カ マ 台 (右)	Hook saddle (right)		1			A120B188H01
321	M9 1509 002	平 ネ ジ	№(28)×22 Screw №(28)×22	2	2	2	2	B509074H01
322	MP 00B0 750	ブ ッ シ ュ	Bushing	2	2	2	2	W445905H01
323	MN 10A0 120	カ マ (組)	Hook complete	2				A190D110P01
	MN 12B0 120	カ マ (組)	Hook complete	2				A190D111P01
	MN 50E1 120	カ マ (組)	Hook complete	2				A190D093P01
	(MN 50E0 120)	カ マ (組)キャップ式	Hook complete (bobbin case type)		2			A190D070P01
	(MN 50A0 120)	カ マ (組)キャップ式	Hook complete(bobbin case type)(sabun)		(2)			A140D021P02
	MN 50A0 120	カ マ (組)	Hook complete		2			A190D090P01
	(MN 52E0 120)	カ マ (組)(佐文)	Hook complete (sabun)		(2)			A190D054P01
324	MN 40A0 123	ボ ビ ン	Bobbin	2				P976017X01
	MN 12B0 123	ボ ビ ン	Bobbin	2				P976002X01
	MN 50A0 123	ボ ビ ン	Bobbin	2				A140D130H02
	MN 52A0 123	ボ ビ ン	Bobbin	2				A140D736H01
325	MN 50A0 245	エ ン ス イ バ ネ	Spring	2				A140D356H02
	MN 52A0 245	エ ン ス イ バ ネ	Spring	2				A140D735H01
327	MF 10E0 148	ヒ	Oil wick	2	2	2	2	W462980H01
328	MP 41A0 302	オ ー プ ナ 支 工 軸	Bobbin case opener holder pin	2	2	2	2	W445901H03
905	MN 40E0 301	オ ー プ ナ 支 工 (組)	Bobbin case opener holder complete	2	2			W458147G05
	MN 42E0 301	オ ー プ ナ 支 工 (組)	Bobbin case opener holder complete	2	2			W458147G07
329	M9 1254 030	特 殊 ネ ジ	№(32)×7.8 Screw №(32)×7.8	2	2	2	2	W445904H01
330	MN 10A0 340	連 接 桿	Link	2	2			W445900H01
	MP 40A0 340	連 接 桿	Link	2	2			A140D580H02
331	MN 10A0 301	オ ー プ ナ 支 工	Bobbin case opener holder	2	2			W445902H01
	MP 40A0 301	オ ー プ ナ 支 工	Bobbin case opener holder	2	2			A140D579H03
332	M9 0102 053	バ ネ 座 金	5 Spring washer 5	2	2	2	2	S913N210P05
333	M9 1251 045	ナ ッ ト	№(32) Nut №(32)	2	2	2	2	B509177H01
334	M9 0910 003	丸 平 ネ ジ	№(40)×7 Screw №(40)×7	2	2	2	2	B509270H01
335	M9 0402 050	座 金	8 Washer 8	2	2	2	2	B508956H01
336	MN 50A0 300	オ ー プ ナ	Opener	2	2			W445903H02
	MN 52A0 300	オ ー プ ナ	Opener	2	2			A140D578H03
337	MN 10A1 342	カ マ 軸 メ タ ル (上)	Hook shaft bushing (upper)	2	2			W445898H02
	MN 12B1 342	カ マ 軸 メ タ ル (上)	Hook shaft bushing (upper)	2	2			W462940H02
338	M9 1203 002	平 ネ ジ	№(28)×15 Screw №(28)×15	2	2	2	2	B509178H01
339	M9 1001 050	座 金	10 Washer10	2	2	2	2	W501041H01
340	MN 10A0 343	カ マ 軸 メ タ ル (下)	Hook shaft bushing (lower)	2	2	2	2	W445899H02
341	M9 0701 050	座 金	9 Washer 9	2	2	2	2	B509331H01
342	M9 1652 002	平 ネ ジ	¼(24)×23 Screw ¼(24)×23	2	2	2	2	W462939H01
343	M9 1201 045	ナ ッ ト	№(28) Nut №(28)	2	2	2	2	W501827H01
344	M9 1205 030	特 殊 ネ ジ	№(28)×11.5 Screw №(28)×11.5	2	2	2	2	A140D129H02
345	M9 1503 001	止 メ ネ ジ	№(28)×4.5 Screw №(28)×4.5	4	4	4	4	B50897H01
346	MN 40A0 344	カ マ 台 (左)	Hook saddle (left)	1				A120B022H01
	MP 40A0 344	カ マ 台 (左)	Hook saddle (left)	1				A120B023H01
	MN 60A0 344	カ マ 台 (左)	Hook saddle (left)		1			A120B190H01
	MN 60A1 344	カ マ 台 (左)	Hook saddle (left)		1			A120B191H01
906	MN 40A0 643	ネ ジ 歯 車 (組)	Gear complete	2	2	2	2	W462927G02
347	M9 1602 001	止 メ ネ ジ	¼(40)×4 Screw ¼(40)×4	8	8	8	8	W500036H01
348	MN 40A0 642	ネ ジ 歯 車 (大)	Gear (large)	2	2	2	2	A130C455H01
349	M9 1655 001	止 メ ネ ジ	¼(40)×6.5 Screw ¼(40)×6.5	2	2	2	2	A141D518H01
350	MN 10A0 643	ネ ジ 歯 車 (小)	Gear (small)	2	2	2	2	W445892H01
351	MN 52E0 125	キ ャ ッ プ	Bobbin case		2			W/CP-12M(230)
	(MN 50E0 125)	キ ャ ッ プ	Bobbin case		(2)			W/CP-12(3)

⑧ 糸切り機構 (I)
 KNIFE MECHANISM (I)

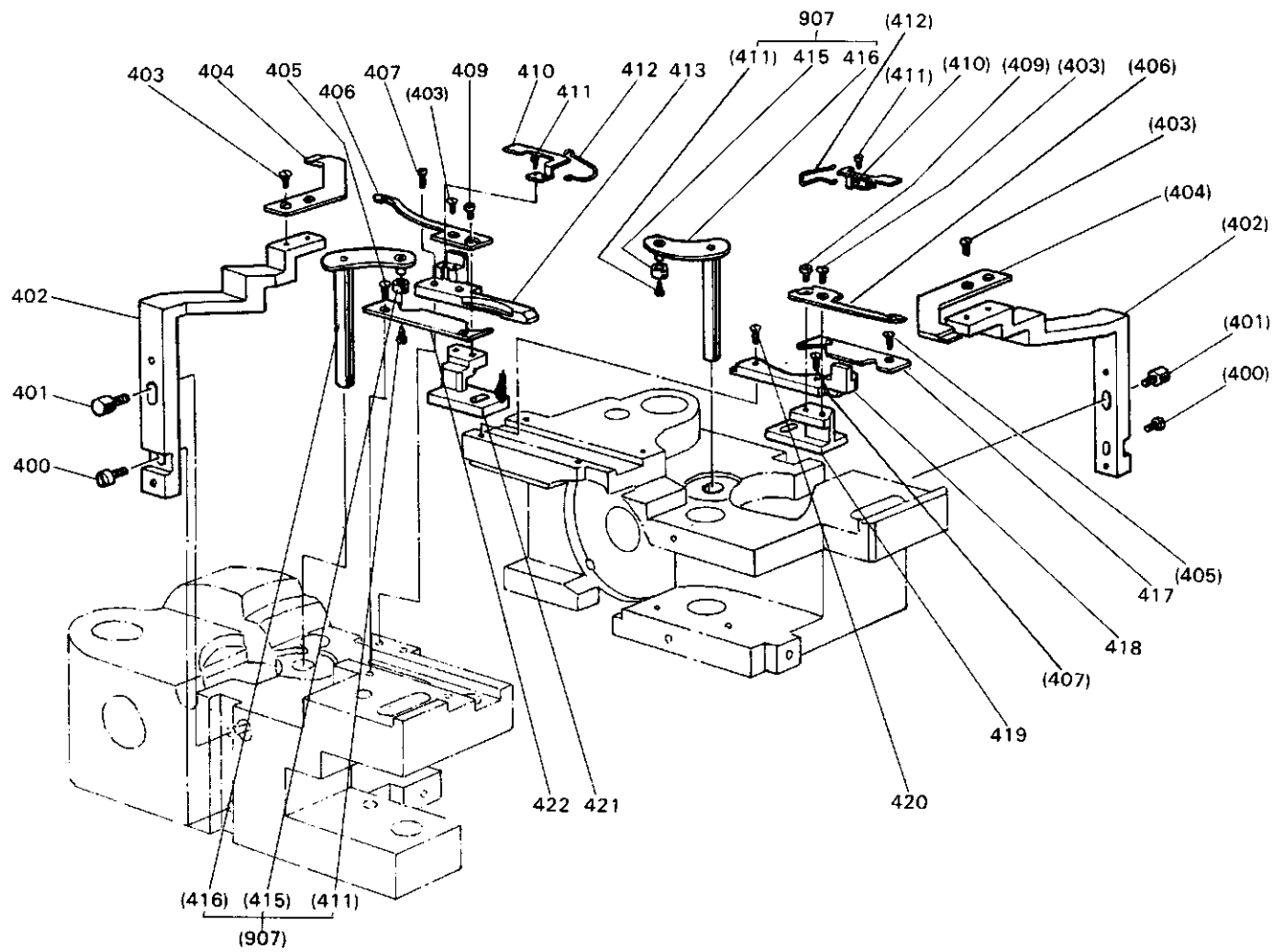

⑧ 糸切り機構(I) KNIFE MECHANISM(I)

Fig. No.	部品コード Part.No.	部 品 名	Description	使用個数 Amt. Req.		資財コード Ref. No.
				112-290 112-290 112-290 112-290	112-290 112-290 112-290 112-290	
400	M9 0911 030	特殊ネジ	$\frac{3}{16}$ (40)×7.....Screw $\frac{3}{16}$ (40)×7.....	2	2	A140D144H01
401	M9 1106 022	ボルトBolt.....	2	2	A140D145H01
402	MN 50A0 839	メス取付台Trimming knife holder.....	2	2	A130C077H02
403	M9 1102 010	皿ネジ	$\frac{3}{16}$ (40)×5.....Screw $\frac{3}{16}$ (40)×5.....	6	6	A140D138H04
404	MN 50A0 838	固定メスFixed blade.....	2	2	A140D751H01
405	M9 0916 011	皿ネジ	$\frac{3}{16}$ (40)×4.....Screw $\frac{3}{16}$ (40)×4.....	4	4	W500697-H01
406	MN 50B0 838	皿移動メスMoved knife.....	2	2	A130C076H03
407	M9 0801 010	皿ネジ	$\frac{1}{8}$ (40)×9.2.....Screw $\frac{1}{8}$ (40)×9.2.....	2	2	W501962-H01
409	M9 0944 002	皿ネジ	$\frac{3}{16}$ (40)×4.5.....Screw $\frac{3}{16}$ (40)×4.5.....	2	2	A141D129H02
410	MN 50A0 192	板バネSpring plate.....	2	2	A140D139H03
411	M9 0605 002	皿ネジ	$\frac{3}{16}$ (56)×3.8.....Screw $\frac{3}{16}$ (56)×3.8.....	6	6	W500679-H01
412	MN 50A0 507	センサイクバネReversing spring.....	2	2	A140D911H01
413	MN 60A1 154	案内金Guide.....	1	1	A141D92H01
	MN 60E1 154	案内金Guide.....	1	1	A141D145G01
907	MN 60A0 950	レバークミタテLever complete.....	2	2	A141D077G02
415	MN 60A0 411	コロRoller.....	2	2	A141D080H01
416	MN 60A1 950	レバLever.....	2	2	A141D078H02
417	MN 60A0 742	皿蓋Cover.....	1	1	A141D090H01
418	MN 60A2 154	案内金Guide.....	1	1	A141D096H02
	MN 60E0 154	案内金Guide.....	1	1	A141D144G02
419	MN 60A0 837	メス台Knife pad.....	1	1	A141D073H02
420	M9 0906 010	皿ネジ	$\frac{3}{16}$ (40)×9.5.....Screw $\frac{3}{16}$ (40)×9.5.....	1	1	A140D138H03
421	MN 60A0 836	メス台Knife pad.....	1	1	A141D075H02
422	MN 60A1 742	皿蓋Cover.....	1	1	A141D093H01

⑨ 糸切り機構 (II)
KNIFE MECHANISM (II)

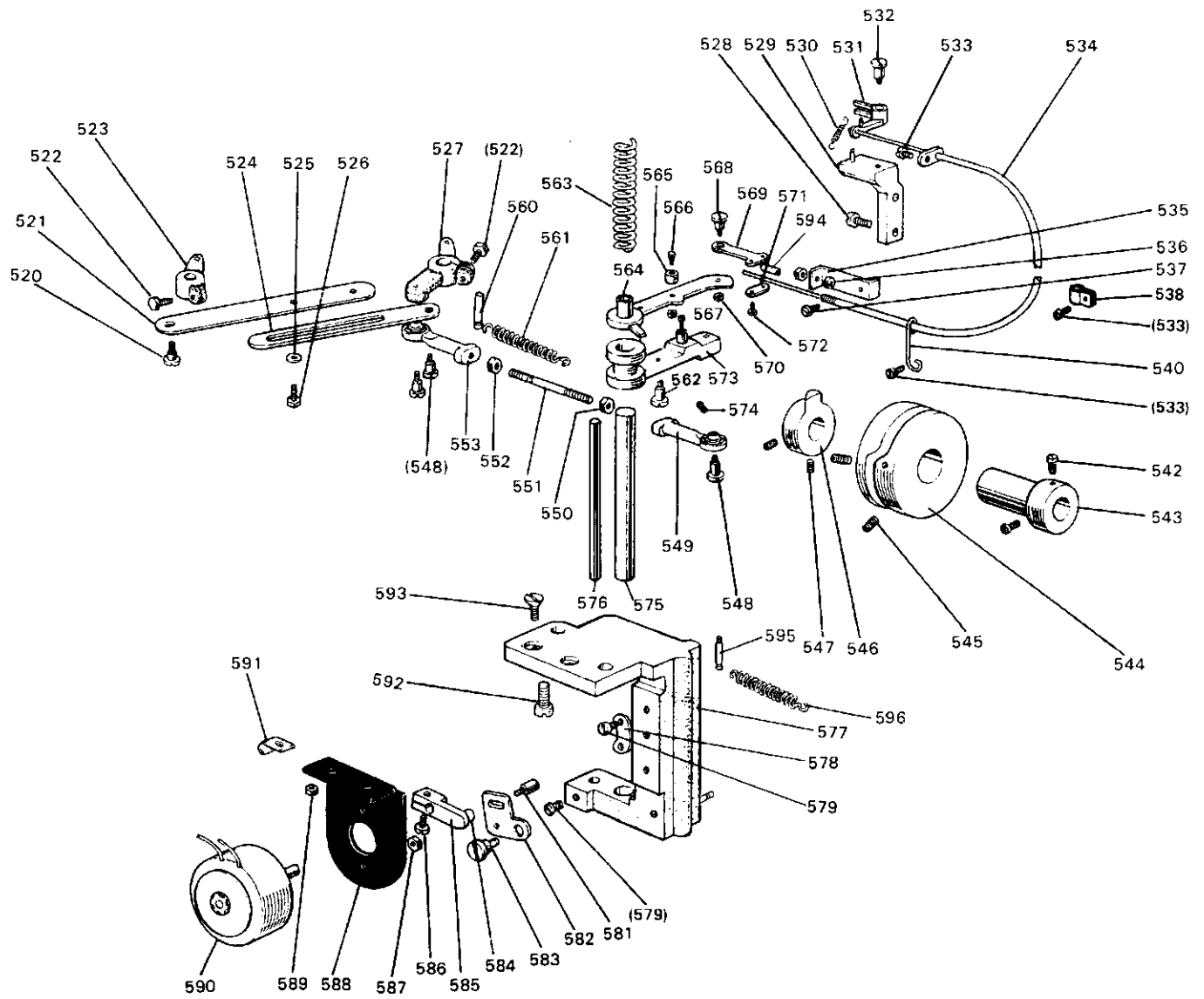

9 糸切り機構(II) KNIFE MECHANISM(II)

Fig. No.	部品コード Part No.	部 品 名	Description	使用個数 Amt. Req.		資財コード Ref. No.
				LITZ-230 M1TW	LITZ-230 BIT	
520	M9 1134 015	平ネジ段付	M5(0.5)×7.5	Screw M5	2 2	A140D357H02
521	MP43A0 910	リンク		Link	1 1	A141D101H01
522	M9 1501 022	ボルト		Bolt	2 2	W501928-H02
523	MN 60A3 228	腕		Arm	1 1	A141D074H01
524	MN 50A0 910	リネジ		Connecting plate	1 1	A140D164H01
525	M9 0550 050	座金	4.5	Washer 4.5	2 2	S913N040P05
526	M9 1201 022	ボルト		Bolt	2 2	W502011-H01
527	MN 60A1 228	腕		Arm	1	A141D076H01
	MN 60A2 228	腕		Arm	1	A141D076H02
528	M9 1110 002	平ネジ	1/4(40)×8	Screw 1/4(40)×8	2 2	W500294H01
529	MN 60A0 172	糸ユルメ台		Thread releasing bracket	1 1	A141D087H01
530	MN 60A3 572	ツルマキバネ		Spring	1 1	A141D089H01
531	MN 60A0 173	糸ユルメ		Thread releasing	1 1	A141D088H01
532	M9 1112 015	平ネジ段付	1/4(40)×5	Screw 1/4(40)×5	1 1	W501531-H01
533	M9 1110 002	平ネジ	1/4(40)×8	Screw 1/4(40)×8	1 1	W500294-H01
534	MN 60E0 746	フレキシブルワイヤ	(組)	Flexible wire complete	1 1	A141D146G01
535	MN 60A0 601	トリツケイタ		Mounting plate	1 1	A141D104H02
536	M9 1373 045	ナット	M5	Nut 5	2 2	S910N010P05
537	M9 1264 015	平ネジ段付	3/8(32)×5.5	Screw 3/8(32)×5.5	1 1	A141D223H01
538	MN 60A0 620	ナイロンクリップ	HP-5N	Nylon clip HP-5N	1 1	S945N220P05
540	MN 60A0 780	ホルダ		Holder	1 1	A141D106H01
542	M9 1516 002	平ネジ	5/8(28)×8.5	Screw 5/8(28)×8.5	2 2	W502945-H02
543	MN 50A0 750	ブッシュ		Bushing	1 1	A140D167H02
544	MN 50A0 350	カム		Cam	1 1	A120B032H01
545	M9 1602 020	六角穴付止メネジ	1/4(40)×9.5	Screw 1/4(40)×9.5	2 2	W462663-H01
546	MN 50A1 350	カム		Cam	1 1	A140D528H03
547	M9 1055 020	六角穴付止メネジ	M4×4	Screw M4×4	2 2	S901N319P09
548	M9 1263 015	平ネジ段付	M5×8.5	Screw M5×8.5	2 2	A141D107H01
549	MF 40A0 975	ロッドエンド		Ball joint	1 1	A190D086P01
550	M9 1377 045	ナット	M5	Nut M5	1 1	A140D402H03
551	M9 5004 023	植込ミボルト		Bolt	1 1	A140D185H02
552	M9 1381 045	ナット	左M5	Nut M5(left)	1 1	A140D402H02
553	MN 50A0 975	ロッドエンド		Ball joint	1 1	A141D140H01
560	M9 5003 067	溝付ピン	BXガタ 5×14	Pin BX-5×14	1 1	A141D148H01
561	MN 50A0 572	ツル巻バネ		Spring	1 1	A140D565H01
562	M9 1111 015	平ネジ段付	1/4(40)×5.5	Screw 1/4(40)×5.5	1 1	W475412H01
563	MN 60A5 572	ツル巻バネ		Spring	1 1	A141D102H01
564	MN 60E0 950	糸ユルメレバー	組立	Thread releasing lever complete	1 1	A130C465G01
565	MN 50A0 411	コロ		Roller	1 1	A140D176H01
566	M9 1131 015	平ネジ段付	1/4(40)×3.6	Screw 1/4(40)×3.6	1 1	A140D177H01
567	M9 1107 045	ナット	1/4(40)	Nut 1/4(40)	1 1	W475413-H01
568	M9 1231 015	平ネジ段付	3/8(28)×5	Screw 3/8(28)×5	1 1	A140D764H01
569	MN 50A0 601	取付板		Mounting plate	1 1	A140D763H01
570	M9 1201 045	ナット	3/8(28)	Nut 3/8(28)	1 1	W501827-H01
571	MN 50A2 750	ブッシュ	(後)	Bushing	1 1	W502917-H03
572	M9 0802 002	平ネジ	1/8(44)×7	Screw 1/8(44)×7	2 2	W501083-H01
573	MN 60A0 886	揺動腕	(組)	Vibrating crank complete	1 1	A140D166H03
574	M9 1001 020	六角穴付止メネジ	1/4(40)×5	Screw 1/4(40)×5	2 2	A140D912H01
575	MN 50A3 454	軸		Shaft	1 1	A140D179H04
576	MN 60A0 454	軸		Shaft	1 1	A141D083H01
577	MN 60A0 603	取付台		Mounting base	1 1	A130C461H01
578	MN 50A0 477	ストップ		Stopper	1 1	A140D172H01
579	M9 1109 002	平ネジ	1/4(40)×7	Screw 1/4(40)×7	3 3	W500511-H01
581	M9 1111 033	ピンネジ	1/4(40)×5	Pin screw 1/4(40)×5	1 1	A140D142H01
582	MN 50A3 950	レバー		Lever	1 1	A140D174H02
583	M9 1103 016	丸平ネジ段付	1/4(40)×3.5	Screw 1/4(40)×3.5	1 1	W475402-H01
584	M9 0615 063	段付ピン		Pin	1 1	A140D184H01
585	MN 50A4 228	腕		Arm	1 1	A140D175H01
586	M9 1112 002	平ネジ	1/4(40)×12	Screw 1/4(40)×12	1 1	W501889-H01
587	M9 1101 045	ナット	1/4(40)	Nut 1/4(40)	1 1	W500657-H01
588	MN 50A3 601	取付板		Set plate	1 1	A140D195H02
589	M9 1373 045	ナット	M5	Nut 5	2 2	S910N010P05
590	MN 50E0 519	ソレノイド	(組立)	Solenoid complete	1 1	A130C286G01
591	MN 50A0 780	ホルダ		Holder	1 1	A140D750H01
592	M9 1603 003	丸平ネジ	1/4(24)×16	Screw 1/4(24)×16	1 1	W501009-H01
593	M9 5001 037	Pサラネジ	5×16	Screw M5×16	2 2	S900N115P16
594	MN 60A0 750	ブッシュ		Bushing	1 1	A141D185H01
595	M9 1111 030	特殊ネジ	1/4(40)×4	Screw 1/4(40)×4	1 1	A141D084H01
596	MN 50A3 572	ツル巻バネ		Spring	1 1	A141D085H01

10 タッチバックおよび検出器機構
TOUCH BACK & DETECTOR MECHANISM

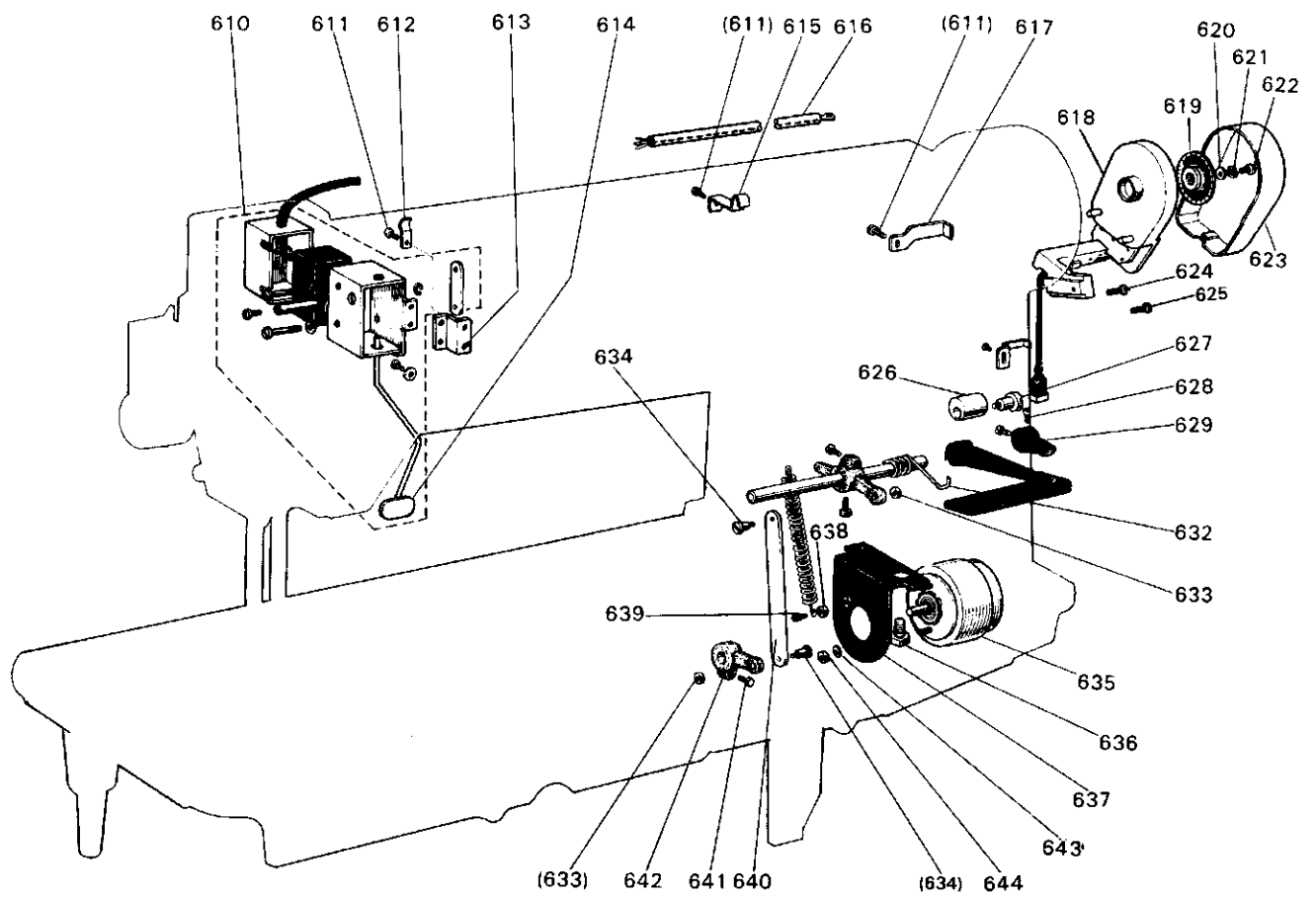

10 タッチバックおよび検出器機構
TOUCH BACK & DETECTOR MECHANISM

Fig. No.	部品コード Part.No.	部 品 名	Description	使用個数 Amt. Req.		資財コード Ref. No.
				LTZ-230 M11W M12-230 M11		
610	MN 50E0 534	タッチスイッチ (組立)	Touch switch complete	1	1	W338227-G03
611	M9 1109 002	平ネジ	1/4(40)×7	4	4	W500511-H01
612	MN 10A1 689	ホルダ	Holder	1	1	W501202-H01
613	MN 50A4 601	取付板	Set plate	1	1	A140D373H01
614	MN 50A4 950	レバ (組立)	Lever complete	1	1	A130C485G01
615	MN 50A1 780	ホルダ	Holder	1	1	A140D532H01
616	M9 7003 095	アース線 (組立)	Earth cord complete	1	1	A140D525G01
617	MF 40A2 415	ホルダ	Holder	1	1	W476457-H01
618	MN 50A0 781	ホルダ台 (組立)	Holding base complete	1	1	A190D025P01
619	MN 50E1 439	遮光円盤 (組立)	Shading disc complete	1	1	A190D024P02
620	M9 1003 050	座金 10	Washer 10	1	1	A140D010H01
621	M9 0901 053	バネ座金 9.3	Spring washer 9.3	1	1	W501036-H01
622	M9 2204 003	丸平ネジ	1/2(28)×15	1	1	A140D009H01
623	MF 90A1 339	カバー	Cover	1	1	A190D003P01
624	M9 1510 002	平ネジ	5/8(28)×12	1	1	W500676-H01
625	M9 1117 002	丸平ネジ	1/2(40)×11.4	1	1	B503844H01
626	MN 50A0 417	ゴムワ	φ16	1	1	A140D358H01
627	M9 1516 015	平ネジ 段付	5/8(28)×5	1	1	A140D102H01
628	M9 1501 002	平ネジ	5/8(28)×8.5	2	2	W502945-H01
629	MN 50A1 950	レバ	Lever	1	1	A140D101H02
632	MN 50A0 729	ヒネリバネ	Spring	1	1	A140D103H01
633	M9 1502 045	ナット	5/8(28)	2	2	W501883-H01
634	M9 1517 015	平ネジ 段付	5/8(28)×14	2	2	A140D192H01
635	M9 1001 095	ロータリソレノイド	Rotary solenoid	1	1	A190D178P01
636	M9 8004 022	ボルト M8	Bolt 8	2	2	S903N012P12
637	MN 50A2 601	取付板	Set plate	1	1	A130C108H02
638	M9 1105 045	ナット	1/2(40)	2	2	W500657-H01
639	M9 1110 002	平ネジ	1/2(40)×8	1	1	W500294-H01
640	MN 50A2 910	リンク	Link	1	1	A140D193H01
641	M9 1502 022	ボルト	Bolt	1	1	W501545-H03
642	MN 50A5 228	腕	Arm	1	1	A140D194H03
643	M9 0104 053	バネ座金 6	Spring washer 6	2	2	S913N210 P06
644	M9 1575 045	ナット M6	Nut M6	2	2	S910N010P06

11 ワイパー機構
WIPER MECHANISM

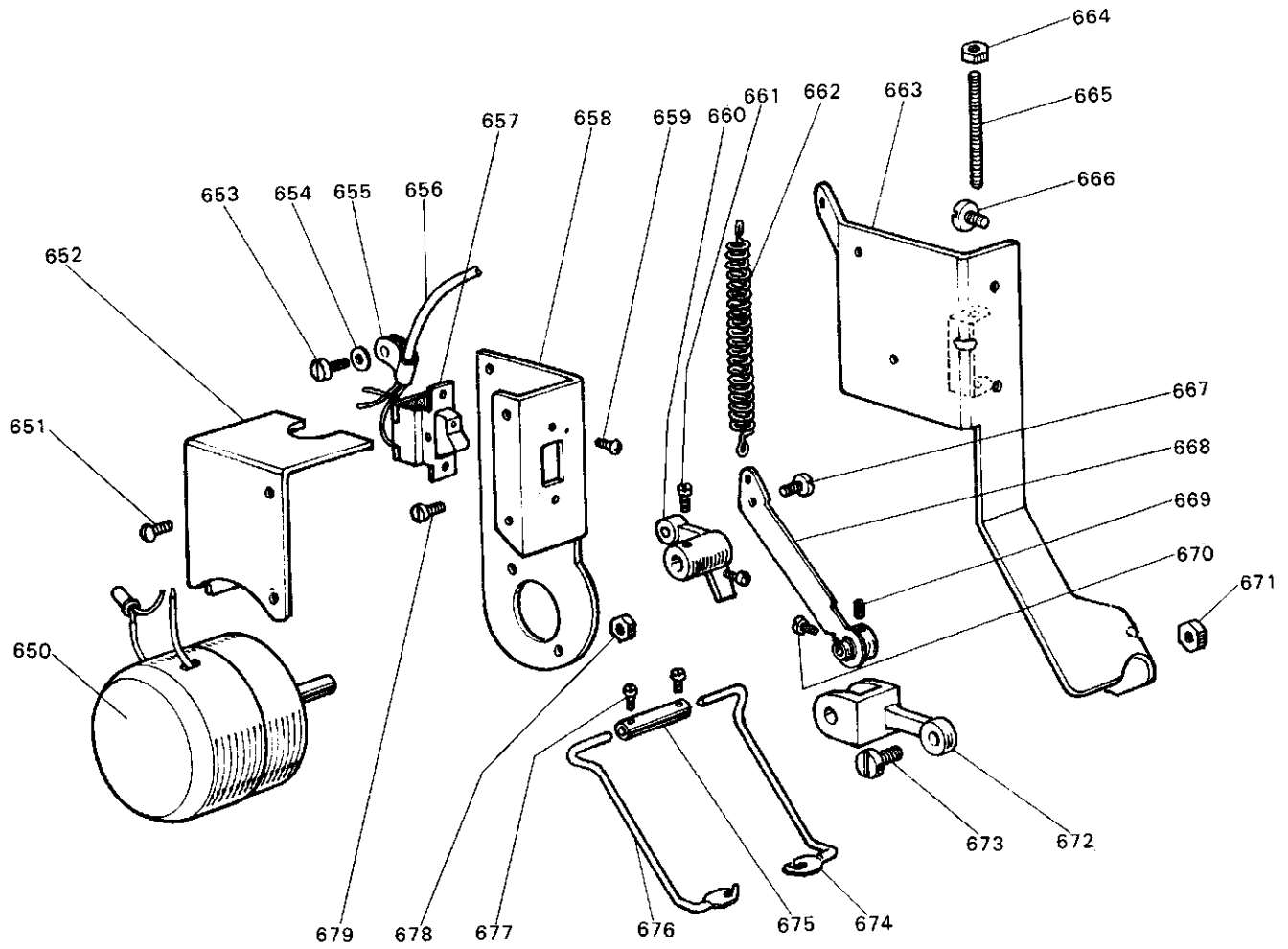

11 ワイパー機構 WIPER MECHANISM

Fig. No.	部品コード Part.No.	部 品 名	Description	使用個数 Amt. Req.	資財コード Ref. No.
650	M9 1003 095	ロータリソレノイド	Rotary solenoid	1	A190D116P01
651	M9 0909 003	丸 平 ネ ジ	Screw $\frac{9}{16}(40) \times 6$	2	W501901H01
652	MN 50E0 339	カ バ ー	Solenoid set cover	1	A130C096G01
653	M9 1104 003	平 ネ ジ	Screw $\frac{1}{4}(40) \times 9$	1	B509264H01
654	M9 0450 050	座 金 4.5	Washer 4.5	1	S913N040P04
655	MN 50A0 620	ナイロンクリップ	HP 3 N Nylon clip HP 3 N	1	S945N220P03
656	M9 7006 095	コ ー ド 組立	Cord complete	1	A130C189G02
657	MF 40E2 484	波 動 ス イ ッ チ	Switch	1	P909001X01
658	MN 50A5 601	ソレノイド台板	Solenoid set plate	1	A130C095G01
659	M9 0336 037	P ナ ベ ネ ジ	Screw M 3 (0.5) $\times 12$	2	S900N012P06
660	MN 40A0 392	駆 動 腕	Connecting crank	1	A141D159H01
661	M9 0813 002	平 ネ ジ	Screw $\frac{1}{8}(44) \times 4.4$	2	W501391H01
662	MN 50A2 572	ツル巻バネ	Spring	1	A140D339H01
663	MN 50E1 601	台板取付板	Set plate for base	1	A130C483G01
664	M9 1201 045	ナ ッ ト	Nut $\frac{3}{16}(28)$	1	W501827H01
665	M9 1205 001	止 メ ネ ジ	Screw $\frac{3}{16}(28) \times 4.2$	1	W500665H01
666	M9 1601 003	丸 平 ネ ジ	Screw $\frac{1}{4}(28) \times 8$	2	W466240H01
667	M9 1133 015	平 ネ ジ	段付 $\frac{1}{4}(40) \times 3.5$ Screw $\frac{1}{4}(40) \times 3.5$	1	W482850H02
668	MN 50E0 954	連 接 桿 組立	Connecting Plate complete	1	A130C094G02
669	M9 1106 001	止 メ ネ ジ	Screw $\frac{1}{4}(40) \times 3.7$	1	B509266H01
670	M9 1127 002	平 ネ ジ	Screw $\frac{1}{4}(40) \times 4$	2	W500193H02
671	M9 1202 045	ナ ッ ト	Nut $\frac{3}{16}(28)$	1	W500001H01
672	MN 40A0 436	ジュウドウリンク	WiPer connecting rod	1	A141D160H01
673	MP 1251 016	丸 平 ネ ジ	段付 $\frac{3}{16}(53) \times 5$ Screw $\frac{3}{16}(53) \times 5$	1	W501953H01
674	MN 50E1 980	糸 サ バ キ 右	Thread take-up controller (right)	1	A130C 4 84H02
675	MN 50A1 454	軸	Rod ($\frac{3}{16} \sim \frac{1}{2}$)	1	A140D332H01
676	MN 50E0 980	糸 サ バ キ 左	Thread take-up controller (left)	1	A130C484H01
677	M9 0813 002	平 ネ ジ	Screw $\frac{1}{8}(44) \times 4.4$	2	W501391H01
678	M9 1101 045	ナ ッ ト	Nut $\frac{1}{4}(40)$	1	W500657H01
679	M9 0909 003	丸 平 ネ ジ	Screw $\frac{9}{16}(40) \times 6$	1	W501901H01

12 給油機構

OIL LUBRICATION MECHANISM

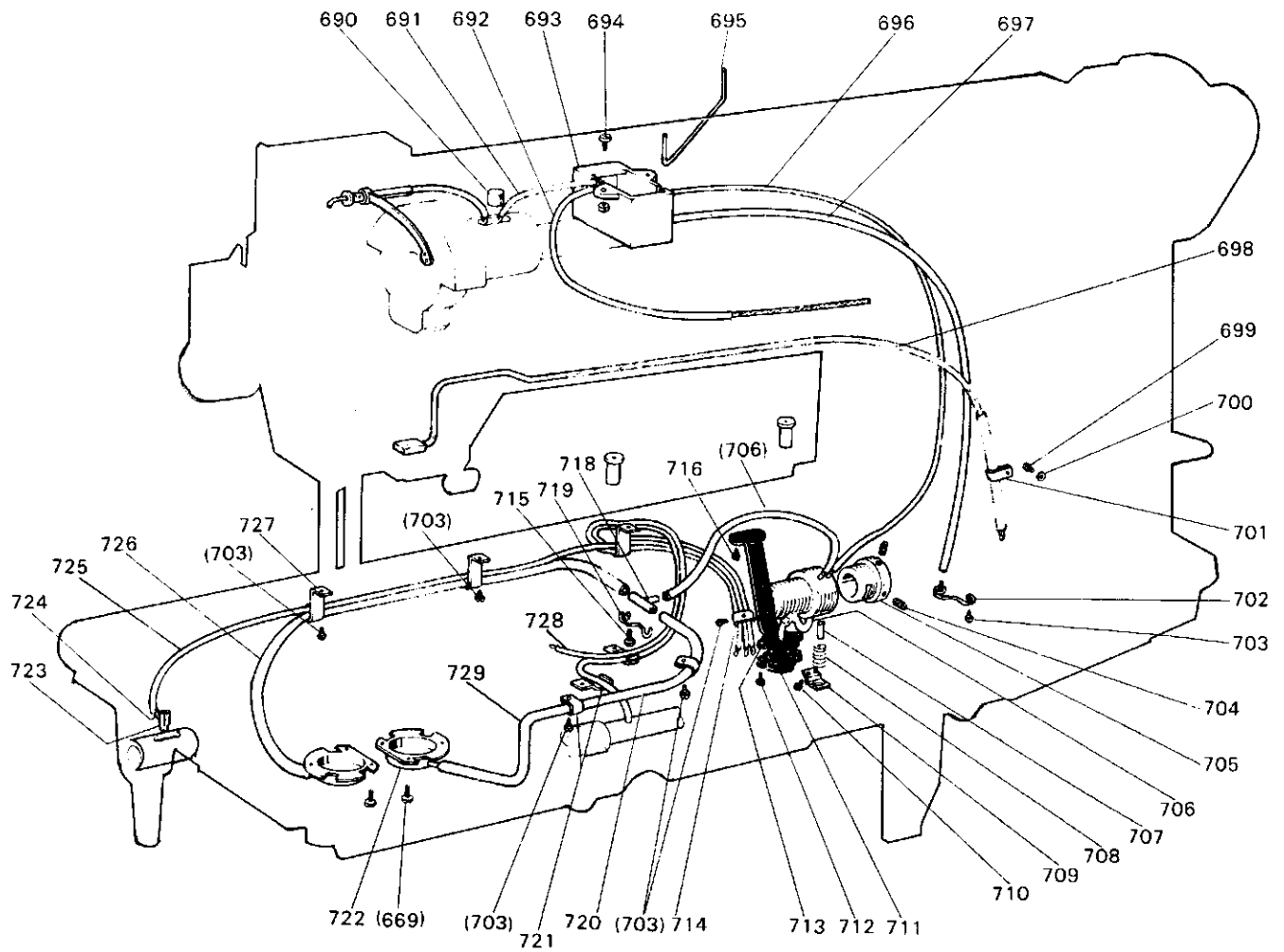

12 給油機構

OIL LUBRICATION MECHANISM

Fig. No.	部品コード Part.No.	部 品 名 Description	使用個数 Amt. Req.				資財コード Ref. No.
			L12-230 M10B	L12-230 E01B	L12-230 M11W	L12-230 BIT	
690	MP 40A2 740	フェルト	1	1	1	1	A140D539H01
691	MP 40E2 688	パイプヒモ (組)	1	1	1	1	A130C083G01
692	MP 40E0 688	パイプヒモ (組)	1	1	1	1	A140D867G01
693	MN 40E0 138	オイルタンク (組)	1	1	1	1	A140D336G01
694	M9 0411 037	ナベネジ M4×16	2	2	2	2	S900N032P16
695	MP 40A0 689	ホルダ	1	1	1	1	A140D858H01
696	MP 40A0 688	パイプ 3D×1×400	1	1	1	1	W488987H03
697	MP 40A1 688	パイプ 5D×1×400	1	1	1	1	A140D551H01
698	MP 40E1 688	パイプ・フェルト (組)	1	1	1	1	A140D920G01
699	M9 0903 002	平ネジ $\frac{3}{8}(40) \times 6.5$	7	7	7	7	B509065H01
700	M9 0304 053	バネ座金 3.5	1	1	1	1	S913N210P03
701	MF 10A0 689	ホルダ	1	1	1	1	W444230H01
702	MP 40A1 689	ホルダ	1	1	1	1	A140D384H01
703	M9 0906 002	平ネジ $\frac{3}{8}(40) \times 4.5$	7	7	7	7	W500791H01
704	M9 1111 001	止メネジ $\frac{3}{8}(40) \times 9.6$	2	2	2	2	B503852H01
705	MN 40A0 750	ブッシュ	1	1	1	1	A140D120H01
706	MP 40A2 688	パイプ 3D×90	2	2	2	2	W488987H10
707	M9 5007 063	特殊ピン	1	1	1	1	W461713H03
708	MN 40A1 572	ツルマキバネ	1	1	1	1	A140D121H01
709	MN 40A0 705	バネ押エ	1	1	1	1	A140D122H01
710	M9 0805 002	平ネジ $\frac{1}{8}(44) \times 4.5$	1	1	1	1	B508852H01
711	MN 40E0 337	フィルター	1	1	1	1	A140D126H01
712	M9 0908 003	丸平ネジ $\frac{3}{8}(40) \times 5$	2	2	2	2	W502003H01
713	MN 40E0 601	取付板 (組)	1	1	1	1	A130C084G02
714	MP 40A4 689	ホルダ	1	1	1	1	A140D127H01
715	M9 0920 002	平ネジ $\frac{3}{8}(40) \times 6.5$	1	1	1	1	W501523H01
716	M9 1118 002	平ネジ $\frac{3}{8}(40) \times 10$	2	2	2	2	B509061H01
718	MP 40A0 571	油ツギテ	1	1	1	1	A140D571H01
719	MP 40A2 689	ホルダ	1	1	1	1	A140D385H01
720	MP 40A3 688	パイプ 3D×1×300	1	1	1	1	W488897H12
721	MF 10A0 689	ホルダ	4	4	4	4	W444230H01
722	MN 50E0 742	フタ (組)	2	2	2	2	A130C090G01
723	MN 50A0 148	ヒモ 2.5×65	2	2	2	2	W488988H11
724	MN 50A1 148	ヒモ 2.5×545	1	1	1	1	W488988H16
725	MP 40A5 688	パイプ 3D×0.5×410	1	1	1	1	W484810H08
726	MP 40A4 688	パイプ 3D×1×445	1	1	1	1	W488897H13
727	MP 40A3 689	ホルダ	3	3	3	3	A140D455H01
728	MP 40E3 688	パイプヒモ クミタテ	1	1	1	1	A140D582G01
729	MP 40E4 688	パイプヒモ クミタテ	1	1	1	1	A140D907G01

13 付属品

ACCESSORIES

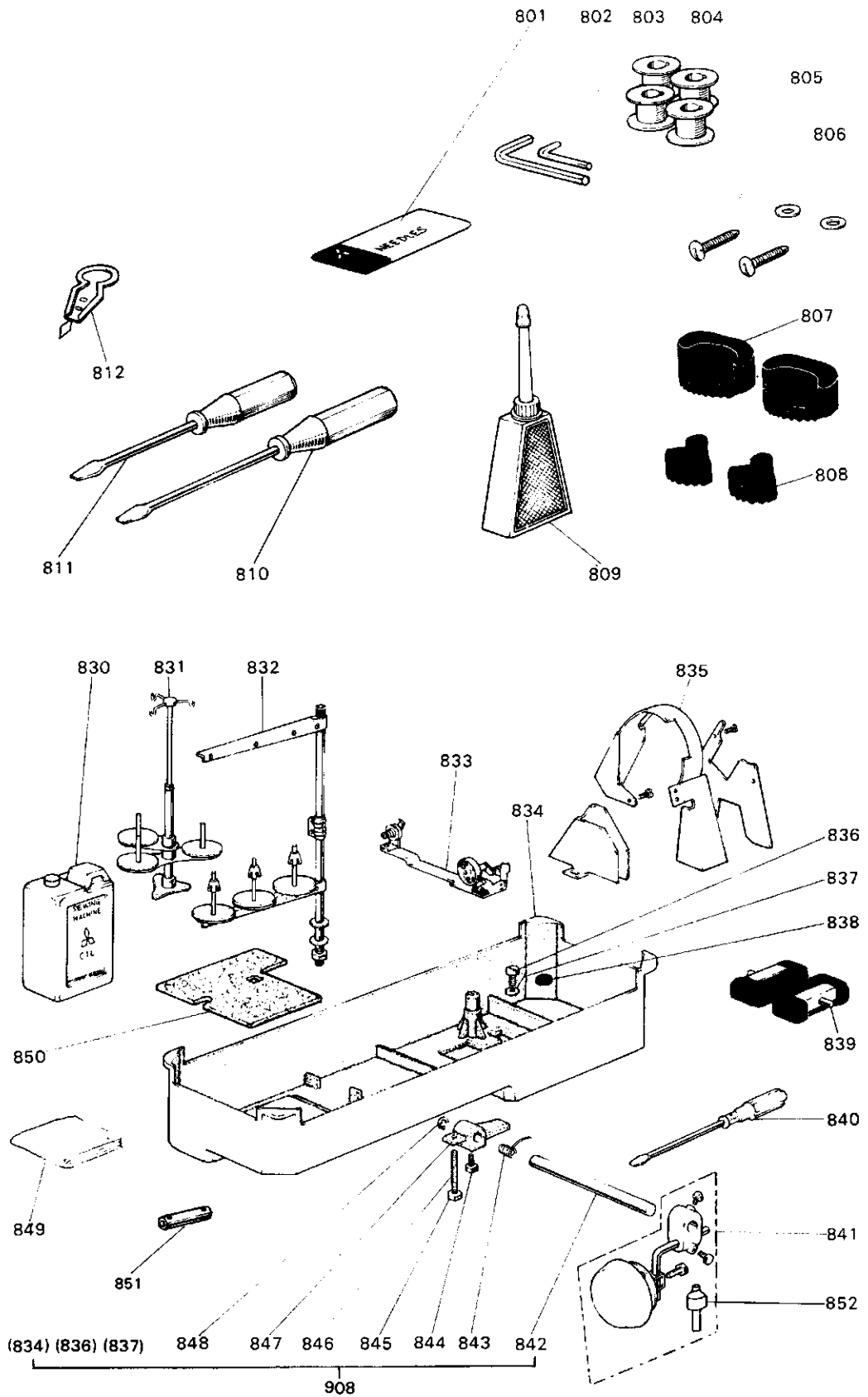













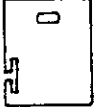

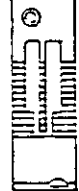
13 付属品

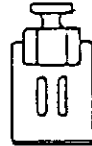
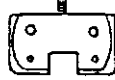
ACCESSORIES

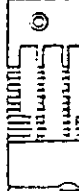
Fig. No.	部品コード Part.No.	部 品 名	Name of Part	使用個数 Amt. Req.		資財コード Ref. No.
				112-220 L112-220 H112-220	112-230 L112-230 H112-230	
801	MV 01A0 128	ミ シ ン 針	DP×5 #14	6	6	S970004H02
	MN 42A0 128	ミ シ ン 針	DP×5 #21	6	6	S970004H06
802	MF 90A0 976	六角棒スパナ	1/8	1	1	W462660H01
803	MF 90A1 976	六角棒スパナ	2.5	1	1	W488545H02
804	MN 40A0 123	ボ ビ ン		4		P976017X01
	MN 12B0 123	ボ ビ ン		4		P976002X01
	MN 50A1 123	ボ ビ ン		4		A140D130H03
	MN 52A0 123	ボ ビ ン		4	4	A140D736H01
805	M9 0403 041	丸 木 ネ ジ	4.5×20	2	2	S908N159P01
806	M9 0601 050	ミ ガ キ 座 金	6	2	2	S913N040P06
807	MN 50A0 419	防 振 ゴ ム		2	2	W476426H03
808	MN 50A1 419	防 振 ゴ ム		2	2	W476426H03
809	MF 60A0 137	油 差 し		1	1	P831002X01
810	MB 02A0 609	ネ ジ 回 し	(中)	1	1	P842003X01
811	MB 02A1 608	ネ ジ 回 し	(小)	1	1	P842002X01
812	MN 10A0 172	糸 通 し 器	(組)	1	1	W479330G01
830	MF 10E0 149	油 缶		1	1	W227466H01
831	MN 10E0 193	糸 立 装 置	3本立(組)	1	1	P995006X01
832	MN 50E0 193	糸 立 装 置	3本立(組)	1	1	A190D081P01
833	MF 20E0 190	糸 巻 仕 掛	(組)	1	1	P992002X01
	MF 67E0 190	糸 巻 仕 掛	(組)	1	1	P992004X01
834	MN 40A0 139	油 槽		1	1	A110A025H03
835	MN 20E0 776	ベルトカバー	(組)(国内のみ)	1	1	W341683G01
	MN 50E0 776	ベルトカバー	(組)(国内のみ)	1	1	A130C159G01
836	M9 2001 004	平 ネ ジ	5/8(28)×8.2	1	1	W486334H01
837	M9 7001 052	特 殊 座 金	14	1	1	W470200H01
838	M9 0701 099	OP - S 磁 石		1	1	P463000X01
839	MF 70E0 418	蝶	(組)	2	2	W481678G01
840	MF 60A0 608	ネ ジ 回 し	(大)	1	1	W319408H01
841	MN 40E0 727	小 物 部 品	(組)	1	1	W341682G06
842	MF 20A1 723	膝 上 ゲ 軸		1	1	W478169H02
843	MF 20A1 729	ヒ ネ リ バ ネ		1	1	W479331H01
844	M9 2001 031	特 殊 ボ ル ト		1	1	B509174H01
845	M9 1506 045	ナ ッ ト	5/8(28)	1	1	W472741H01
846	M9 1520 001	止 メ ネ ジ	5/8(28)×27	1	1	B503980H01
847	MF 40A0 724	膝 上 ゲ 腕		1	1	A140D204H01
848	M9 0515 065	E 形 止 メ 輪	9	1	1	S922N210P90
849	MF 60A0 734	ビ ニール カ バ ー		1	1	W220627H02
850	MN 40A0 740	フ ェ ル ト		1	1	A130C427H02
851	MN 50A4 454	軸 (糸サキ用)	(5/8~1 1/2)	1		A130C332H02
852	MN 40A0 578	膝 上 ゲ ビ ン		1	1	A130C089G01
908	MN 40E0 139	油 槽	(組)	1	1	A130C158G01

14 ゲージ部品表

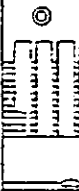
GAUGE PARTS LIST

針板 Needle Plate		送り Feed Dog		押え Presser Foot	針タキ Needle Clamp	スベリ板(左) Slide Plate(L)	スベリ板(右) Slide Plate(R)
LT2-220 MOB, BOB	LT2-230 MITW, BIT	LT2-220-MOB BOB LT2-230-MITW	LT2-230-BIT LT2-230 (デニム Denim)				
$3/32 \sim 5/32$	$3/32 \sim 5/32 (3/16)$	$3/32 \sim 5/32 (3/16)$	$3/32 \sim 5/32 (3/16)$	LT2-220BOB LT2-230BIT $3/32 \sim 1/4$			
					$3/32 \sim 5/8$	Fig 551 植え込みホルト Connecting bolt	
$3/16 \sim 3/8$	$3/16 \sim 3/8$	$3/16 \sim 3/8$	$3/16 \sim 3/8$	LT2-220MOB LT2-230MITW $3/32 \sim 1/2$		$3/32 \sim 5/8$ $3/4 \sim 1/4$ M95004023 M95006023	
					$3/4 \sim 1/2$		
$1/2 \sim 3/4$	$1/2 \sim 3/4$	$1/2 \sim 3/4$	$1/2 \sim 3/4$				
							
$1 \sim 1 1/2$	$1" \sim 1 1/4$	$1" \sim 1 1/2$	$1" \sim 1 1/4$				

● ゲージ部品共通性一覧表
Comparison List for Gauge parts

機種名 Model Name	部品名 Part Name	針タキ Needle Clamp	押え Presser Foot	送り Feed Dog	針板 Needle Plate	スベリ板 Slide Plate		備考 Remarks
						左 (L)	右 (R)	
糸切りナシ With Trimmer	LT2-220MOB (5%送り・Feed)	DN260-10						
	LT2-220BOB (7%送り・Feed)	DN260-10	DN275-20	DN260-20	DN275-20	DN260-10		
糸切り付 With Trimmer	LT2-230MITW (5%送り・Feed)	DN260-10		専用 Special				
	LT2-230BIT (7%送り・Feed)	DN260-20	DN275-20	専用 Special		LT2-230MITW		

14 ゲージ部品表
GAUGE PARTS LIST

部品コード Parts No.

針寸法 Gauge Size	針板 Needle Plate	送り Feed Dog	送り(デニム) Feed Dog (for Denim)	押工 Presser foot	針タキ Needle Clamp	スベリ板(左) Slide plate(L)	スベリ板(右) Slide plate(R)
Type LT2-220MOB							
$\frac{3}{8}$ (2.4 $\frac{m}{m}$)	MN10J3101	MN10J3104		MN10J3105	MN10J3102	MN10A0473	MN10A0474
$\frac{1}{4}$ (3.2 $\frac{m}{m}$)	MN10J4101	MN10J4104		MN10J4105	MN10J4102	"	"
$\frac{5}{16}$ (4.0 $\frac{m}{m}$)	MN10J5101	MN10J5104		MN10J5105	MN10J5102	"	"
$\frac{3}{16}$ (4.8 $\frac{m}{m}$)	MN10J6101	MN10J6104		MN10J6105	MN10J6102	"	"
$\frac{7}{32}$ (5.6 $\frac{m}{m}$)	MN10J7101	MN10J7104		MN10J7105	MN10J7102	"	"
$\frac{1}{2}$ (6.4 $\frac{m}{m}$)	MN10J8101	MN10J8104		MN10J8105	MN10J8102	"	"
$\frac{5}{16}$ (8.0 $\frac{m}{m}$)	MN10J9101	MN10J9104		MN10J9105	MN10J9102	MP20B1473	"
$\frac{3}{8}$ (9.5 $\frac{m}{m}$)	MN10K1101	MN10K1104		MN10K1105	MN10K1102	"	"
$\frac{1}{2}$ (12.7 $\frac{m}{m}$)	MN10K3101	MN10K3104		MN10K3105	MN10K3102	MP00B0473	"
$\frac{5}{8}$ (16.0 $\frac{m}{m}$)	MN10K4101	MN10K4104		MN10K4105	MN10K4102	"	"
$\frac{3}{4}$ (19.0 $\frac{m}{m}$)	MN10K5101	MN10K5104		MN10K5105	MN10K5102	MN10A1473	MP20B2474
1 (25.4 $\frac{m}{m}$)	MN10K6101	MN10K6104		MN10K6105	MN10K6102	MP20B3473	"
1 $\frac{1}{4}$ (28.5 $\frac{m}{m}$)	MN10K7101	MN10K7104		MN10K7105	MN10K7102	MN40A0473	"
1 $\frac{1}{2}$ (31.8 $\frac{m}{m}$)	MN10K8101	MN10K8104		MN10K8105	MN10K8102	"	"
1 $\frac{3}{4}$ (38.1 $\frac{m}{m}$)	MN10K9101	MN10K9104		MN10K9105	MN10K9102	MN40A1473	"
Type LT2-220MOB							
$\frac{3}{8}$ (2.4 $\frac{m}{m}$)	MN42J3101	MN10J3104		MN52J3105	MN10J3102	MN10A0473	MN10A0474
$\frac{1}{4}$ (3.2 $\frac{m}{m}$)	MN26J4101	MN12J4104		MN26J4105	MN10J4102	"	"
$\frac{5}{16}$ (4.0 $\frac{m}{m}$)	MN42J5101	MN12J5104		MN52J5105	MN10J5102	"	"
$\frac{3}{16}$ (4.8 $\frac{m}{m}$)	MN26J6101	MN26J6104		MN26J6105	MN10J6102	"	"
$\frac{7}{32}$ (5.6 $\frac{m}{m}$)	MN42J7101	MN12J7104		MN52J7105	MN10J7102	"	"
$\frac{1}{2}$ (6.4 $\frac{m}{m}$)	MN26J8101	MN26J8104		MN26J8105	MN10J8102	"	"
$\frac{5}{16}$ (8.0 $\frac{m}{m}$)	MN26J9101	MN26J9104		MN26J9105	MN10J9102	MP20B1473	"
$\frac{3}{8}$ (9.5 $\frac{m}{m}$)	MN26K1101	MN26K1104		MN26K1105	MN10K1102	"	"
$\frac{1}{2}$ (12.7 $\frac{m}{m}$)	MN26K3101	MN12K3104		MN26K3105	MN10K3102	MP00B0473	"
$\frac{5}{8}$ (16.0 $\frac{m}{m}$)	MN42K4101	MN12K4104		MN52K4105	MN10K4102	"	"
$\frac{3}{4}$ (19.0 $\frac{m}{m}$)	MN42K5101	MN12K5104		MN52K5105	MN10K5102	MN10A1473	MP20B2474
1 (25.4 $\frac{m}{m}$)	MN42K6101	MN12K6104		MN52K6105	MN10K6102	MP20B3473	"
1 $\frac{1}{4}$ (28.5 $\frac{m}{m}$)	MN42K7101	MN12K7104		MN52K7105	MN10K7102	MN40A0473	"
1 $\frac{1}{2}$ (31.8 $\frac{m}{m}$)	MN42K8101	MN12K8104		MN52K8105	MN10K8102	"	"
Type LT2-230M1TW							
$\frac{3}{8}$ (2.4 $\frac{m}{m}$)	MN50J3101	MN50J3104	MN51J3104	MN10J3105	MN10J3102	MN50A0473	MN50A0474
$\frac{1}{4}$ (3.2 $\frac{m}{m}$)	MN50J4101	MN50J4104	MN51J4104	MN10J4105	MN10J4102	"	"
$\frac{5}{16}$ (4.0 $\frac{m}{m}$)	MN50J5101	MN50J5104	MN51J5104	MN10J5105	MN10J5102	"	"
$\frac{3}{16}$ (4.8 $\frac{m}{m}$)	MN50J6101	MN50J6104	MN51J6104	MN10J6105	MN10J6102	"	"
$\frac{7}{32}$ (5.6 $\frac{m}{m}$)	MN50H6101	MN50H6104	MN51H6104	MN10J6105	MN10J6102	"	"
$\frac{1}{2}$ (6.4 $\frac{m}{m}$)	MN50J7101	MN50J7104	MN51J7104	MN10J7105	MN10J7102	"	"
$\frac{5}{16}$ (8.0 $\frac{m}{m}$)	MN50J8101	MN50J8104	MN51J8104	MN10J8105	MN10J8102	"	"
$\frac{3}{8}$ (9.5 $\frac{m}{m}$)	MN50J9101	MN50J9104	MN51J9104	MN10J9105	MN10J9102	MN50A1473	"
$\frac{1}{2}$ (12.7 $\frac{m}{m}$)	MN50K1101	MN50K1104	MN51K1104	MN10K1105	MN10K1102	"	"
$\frac{5}{8}$ (16.0 $\frac{m}{m}$)	MN50K3101	MN50K3104	MN51K3104	MN10K3105	MN10K3102	MN50A2473	"
$\frac{3}{4}$ (19.0 $\frac{m}{m}$)	MN50K4101	MN50K4104	MN51K4104	MN10K4105	MN10K4102	"	"
1 (25.4 $\frac{m}{m}$)	MN50K5101	MN50K5104	MN51K5104	MN10K5105	MN10K5102	MN50A3473	MN50A1474
1 $\frac{1}{4}$ (28.5 $\frac{m}{m}$)	MN50K6101	MN50K6104	MN51K6104	MN10K6105	MN10K6102	MN50A4473	"
1 $\frac{1}{2}$ (31.8 $\frac{m}{m}$)	MN50K7101	MN50K7104	MN51K7104	MN10K7105	MN10K7102	MN50A5473	"
1 $\frac{3}{4}$ (38.1 $\frac{m}{m}$)	MN50K8101	MN50K8104	MN51K8104	MN10K8105	MN10K8102	"	"
Type LT2-230B1T							
$\frac{3}{8}$ (2.4 $\frac{m}{m}$)	MN52J3101	MN52J3104		MN52J3105	MN10J3102	MN50A0473	MN50A0474
$\frac{1}{4}$ (3.2 $\frac{m}{m}$)	MN52J4101	MN52J4104		MN26J4105	MN10J4102	"	"
$\frac{5}{16}$ (4.0 $\frac{m}{m}$)	MN52J5101	MN52J5104		MN52J5105	MN10J5102	"	"
$\frac{3}{16}$ (4.8 $\frac{m}{m}$)	MN52J6101	MN52J6104		MN26J6105	MN10J6102	"	"
$\frac{7}{32}$ (5.6 $\frac{m}{m}$)	MN52H6101	MN52H6104		MN26J6105	MN10J6102	"	"
$\frac{1}{2}$ (6.4 $\frac{m}{m}$)	MN52J7101	MN52J7104		MN52J7105	MN10J7102	"	"
$\frac{5}{16}$ (8.0 $\frac{m}{m}$)	MN52J8101	MN52J8104		MN26J8105	MN10J8102	"	"
$\frac{3}{8}$ (9.5 $\frac{m}{m}$)	MN52J9101	MN52J9104		MN26J9105	MN10J9102	MN50A1473	"
$\frac{1}{2}$ (12.7 $\frac{m}{m}$)	MN52K1101	MN52K1104		MN26K1105	MN10K1102	"	"
$\frac{5}{8}$ (16.0 $\frac{m}{m}$)	MN52K3101	MN52K3104		MN26K3105	MN10K3102	MN50A2427	"
$\frac{3}{4}$ (19.0 $\frac{m}{m}$)	MN52K4101	MN52K4104		MN52K4105	MN10K4102	"	"
1 (25.4 $\frac{m}{m}$)	MN52K5101	MN52K5104		MN52K5105	MN10K5102	MN50A3473	MN50A1474
1 $\frac{1}{4}$ (28.5 $\frac{m}{m}$)	MN52K6101	MN52K6104		MN52K6105	MN10K6102	MN50A4473	"
1 $\frac{1}{2}$ (31.8 $\frac{m}{m}$)	MN52K7101	MN52K7104		MN52K7105	MN10K7102	MN50A5473	"
1 $\frac{3}{4}$ (38.1 $\frac{m}{m}$)	MN52K8101	MN52K8104		MN52K8105	MN10K8102	"	"